



3000 Series PXI Modules

Common Installation Guide

© Aeroflex International Ltd. 2008

No part of this document may be reproduced or transmitted in any form or by any means, electronic or mechanical, including photocopying, or recorded by any information storage or retrieval system, without permission in writing by Aeroflex International Ltd. (hereafter referred to throughout the document as 'Aeroflex').

Document part no. 46892/663

Issue 11

20 October 2008

Introduction

This installation guide covers all Aeroflex PXI 3000 Series modules.

It explains how to install driver software, and how to fit the module into the chassis.

PXI Studio is a supplied application that helps you to configure two or more modules to create test instruments and run measurement utilities. Modules are formatted automatically to provide the chosen measurement capabilities, and soft front panels create virtual instruments with familiar and intuitive controls.

Operating manuals

There is a separate operating manual for each 3000 Series module. Each manual contains information about connecting and operating the module, an explanation of the soft front panel, driver functions, and technical description. Manuals also contain basic acceptance testing. All the operating manuals are included on the PXI Modules CD-ROM, part no. 46886/028.

Declaration of Conformity

If you require a copy of the Declaration of Conformity (which covers all PXI 3000 Series modules), please refer to your local representative.

IOCreator® is a registered trademark of Aeroflex International Inc. in the US

Microsoft® is a registered trademark of Microsoft Corporation

Windows™, Windows XP™ and Windows NT™ are trademarks of Microsoft Corporation

National Instruments™ and NI-VISA™ are trademarks of National Instruments Corporation.

Associated documentation

PXI Modules CD-ROM	Part no. 46886/028	Compilation containing PXI module software installer, soft front panels, drivers, DLL components, COM interfaces, help files, data sheets, application notes and operating manuals for all modules in the 3000 Series.
Operating manuals	Part no.	
	46892/637	3010/3011 RF Synthesizer
	46892/638	3020 Digital RF Signal Generator
	46892/717	3020A Digital RF Signal Generator
	46892/721	3025 6 GHz Digital RF Signal Generator
	46892/834	3025C 6 GHz Digital RF Signal Generator
	46892/639	3030 RF Digitizer
	46882/718	3030A RF Digitizer
	46882/835	3030C RF Digitizer
	46882/722	3035 6 GHz RF Digitizer
	46882/836	3035C 6 GHz RF Digitizer
	46892/640	3060 RF Combiner
	46892/762	3065 6 GHz RF Combiner
Installation Guide for Chassis	Part no. 46892/667	Provides an overview of a configured PXI system comprising Aeroflex modules installed in a PXI chassis, together with a PXI controller, drivers and application software. Explains how to set up a populated chassis ready for use.
3000/3000A Chassis and 3001A System Controller User Guide	Part no. 46892/837	Overview, installation, pin assignments and maintenance information for chassis and system controller.
PXI Studio User Guide	Part no. 46892/809	Setting up and using the universal PXI application for system configuration and operation.
Getting Started with afDigitizer	46892/676	Setting up and using the digitizer application for the 3010 and 3030 Series modules.
Getting Started with afSigGen	46892/678	Setting up and using the signal generator application for the 3010 and 3020 Series modules.

Contents

Precautions	vi
Précautions	ix
Vorsichtsmaßnahmen	xii
Precauzioni	xv
Precauciones	xviii
Installing a 3000 Series PXI module	1
Introduction	1
Naming conventions	1
Unpacking the module	1
Contents of packing	1
Handling precautions	2
Initial visual check	2
Typical system	3
System requirements	3
Tools required	3
Software architecture	4
Which interface to use?	5
Installation process	6
General	6
Order of installation	8
Uninstalling PXI module software	9
Removing previous versions of application software	9
Driver version	10
Checking the software compatibility of a PXI module	10
Installing PXI module software	11
Installation locations	11
Installation procedure	11
Installing PXI Studio application software	17
Installing additional application software packages	17
Installing chassis and controller software	17
Hardware installation	18
Check the safety documentation	18
Installing the 3000 Series module into the chassis	19
Connecting and torquing SMA connectors	20
For PCI-to-PXI interface kit users	20
For PXI embedded controller users	20
For Windows NT users	21
For Windows 2000, Me, XP users	21
Removing the module	24
Connector maintenance	24
Using the installed software	25
Running the soft front panel	25
Operating manuals	26
Contents of installation folder	26
Other installed items	26

INTRODUCTION

Identifying modules installed in a chassis.....	26
Repackaging.....	28

Precautions

WARNING

CAUTION

Note

These terms have specific meanings in this manual:

WARNING

information to prevent personal injury.

CAUTION

information to prevent damage to the equipment.

Note

important general information.

Hazard symbols

The meaning of hazard symbols appearing on the equipment and in the documentation is as follows:

Symbol

Description



Refer to the operating manual when this symbol is marked on the instrument. Familiarize yourself with the nature of the hazard and the actions that may have to be taken.



Dangerous voltage



Toxic hazard

General conditions of use

This product is designed and tested to comply with the requirements of IEC/EN61010-1 ‘Safety requirements for electrical equipment for measurement, control and laboratory use’, for Class III equipment and is for use in a pollution degree 2 environment. The equipment is designed to operate from an installation category I supply.

Equipment should be protected from the ingress of liquids and precipitation such as rain, snow, etc. When moving the equipment from a cold to a hot environment, it is important to allow the temperature of the equipment to stabilize before it is connected to the supply to avoid condensation forming. The equipment must only be operated within the environmental conditions specified in the data sheet, otherwise the protection provided by the equipment may be impaired.

This product is not approved for use in hazardous atmospheres or medical applications. If the equipment is to be used in a safety-related application, e.g. avionics or military applications, the suitability of the product must be assessed and approved for use by a competent person.

WARNING



Electrical hazards (DC supply voltage)

This equipment conforms with IEC safety Class III, meaning that for continued safety it must only be connected to supplies and signal sources which conform to ‘Separated Extra-Low Voltage’ (SELV and SELV-E) voltage and insulation requirements. No hazardous voltages are generated internally. See the data sheet for the maximum permitted voltage levels that can be applied.

Do not remove instrument covers as this may result in personal injury. There are no user-serviceable parts inside.

Refer all servicing to qualified personnel. See list of Service Centers at rear of manual.

WARNING



Toxic hazards

Some of the components used in this equipment may include resins and other materials which give off toxic fumes if incinerated. Take appropriate precautions, therefore, in the disposal of these items.

WARNING



Beryllium copper

It is possible that some mechanical components within this instrument may be manufactured from beryllium copper. This is an alloy with a beryllium content of approximately 5%. It represents no risk in normal use.

The material should not be machined, welded or subjected to any process where heat is involved.

It must be disposed of as “special waste”.

It must NOT be disposed of by incineration.

CAUTION



Static sensitive components

This equipment contains static sensitive components which may be damaged by handling.

CAUTION

Suitability for use

This equipment has been designed and manufactured by Aeroflex to generate low-power RF signals for testing radio communications apparatus and to digitize and provide spectrum analysis of RF signals.

If the equipment is not used in a manner specified by Aeroflex, the protection provided by the equipment may be impaired.

Aeroflex has no control over the use of this equipment and cannot be held responsible for events arising from its use other than for its intended purpose.

Précautions

WARNING

CAUTION

Note

Les termes suivants ont, dans ce manuel, des significations particulières:

WARNING

contient des informations pour éviter toute blessure au personnel.

CAUTION

contient des informations pour éviter les dommages aux équipements.

Note

contient d'importantes informations d'ordre général.

Symboles signalant un risque

La signification des symboles de danger apparaissant sur l'équipement et dans la documentation est la suivante:

Symbole

Nature du risque



Reportez-vous au manuel d'utilisation quand ce symbole apparaît sur l'instrument. Familiarisez-vous avec la nature du danger et la conduite à tenir.



Tension dangereuse



Danger produits toxiques

Conditions générales d'utilisation

Ce produit a été conçu et testé pour être conforme aux exigences des normes CEI/EN61010-1 "Règles de sécurité pour appareils électriques de mesurage, de régulation et de laboratoire", pour des équipements Classe III et pour une utilisation dans un environnement de pollution de niveau 2. Cet équipement est conçu pour fonctionner à partir d'une alimentation de catégorie I.

Cet équipement doit être protégé de l'introduction de liquides ainsi que des précipitations d'eau, de neige, etc... Lorsqu'on transporte cet équipement d'un environnement chaud vers un environnement froid, il est important de laisser l'équipement se stabiliser en température avant de le connecter à une alimentation afin d'éviter toute formation de condensation. L'appareil doit être utilisé uniquement dans le cadre des conditions d'environnement spécifiées dans la fiche technique, toute autre utilisation peut endommager les systèmes de protection.

Ce produit n'est pas garanti pour fonctionner dans des atmosphères dangereuses ou pour un usage médical. Si l'équipement doit être utilisé pour des applications en relation avec la sécurité, par exemple des applications militaires ou aéronautiques, la compatibilité du produit doit être établie et approuvée par une personne compétente.

WARNING



Sécurité électrique (tension d'alimentation continue)

Cet équipement est conforme aux normes de sécurité CEI Classe III, c'est-à-dire qu'il ne doit être connecté qu'à des sources d'alimentation ou de signaux qui suivent les recommandations de tension et d'isolement du type 'Tension extra-faible séparée' (SELV at SELV-E). Aucune tension dangereuse n'est générée en interne. La fiche technique précise les niveaux de tension maximum acceptables en entrée.

Ne démontez pas le capot de l'instrument, car ceci peut provoquer des blessures. Il n'y a pas de pièces remplaçables par l'utilisateur à l'intérieur.

Faites effectuer toute réparation par du personnel qualifié. Contacter un des Centres de Maintenance Internationaux dans la liste jointe à la fin du manuel.

WARNING



Danger produits toxiques

Certains composants utilisés dans cet appareil peuvent contenir des résines et d'autres matières qui dégagent des fumées toxiques lors de leur incinération. Les précautions d'usages doivent donc être prises lorsqu'on se débarrasse de ce type de composant.

WARNING



Bronze au béryllium

Il est possible que dans cet équipement, certaines pièces mécaniques sont à base de bronze au béryllium. Il s'agit d'un alliage dans lequel le pourcentage de béryllium ne dépasse pas 5%. Il ne présente aucun danger en utilisation normale.

Toutefois, cet alliage ne doit pas être travaillé, soudé ou soumis à un processus qui implique l'utilisation d'une source de chaleur.

En cas de destruction, il sera entreposé dans un container spécial. IL ne devra pas être détruit par incinération.

CAUTION

Utilisation

Cet équipement a été conçu et fabriqué par Aeroflex pour générer des signaux RF de faible puissance pour le test d'appareils de radio communications et numériser et analyser le spectre de signaux RF.

La protection de l'équipement peut être altérée s'il n'est pas utilisé dans les conditions spécifiées par Aeroflex. Aeroflex n'a aucun contrôle sur l'usage de l'instrument, et ne pourra être tenu pour responsable en cas d'événement survenant suite à une utilisation différente de celle prévue.

Vorsichtsmaßnahmen

WARNING

CAUTION

Note

Diese Hinweise haben eine bestimmte Bedeutung in diesem Handbuch:

WARNING

dienen zur Vermeidung von Verletzungsrisiken.

CAUTION

dienen dem Schutz der Geräte.

Note

enthalten wichtige Informationen.

Gefahrensymbole

Die Bedeutung der Gefahrensymbole auf den Geräten und in der Dokumentation ist wie folgt:

Symbol

Gefahrenart



Beziehen Sie sich auf die Bedienungsanleitung wenn das Messgerät mit diesem Symbol markiert ist. Machen Sie sich mit der Art der Gefahr und den Aktionen die getroffen werden müssen bekannt.



Gefährliche Spannung



Warnung vor giftigen Substanzen

Allgemeine Hinweise zur Verwendung

Dieses Produkt wurde entsprechend den Anforderungen von IEC/EN61010-1 "Sicherheitsanforderungen für elektrische Ausrüstung für Meßaufgaben, Steuerung und Laborbedarf", Klasse III, zur Verwendung in einer Grad 2 verunreinigten Umgebung, entwickelt und getestet. Dieses Gerät ist für Netzversorgung Klasse I zugelassen.

Das Gerät sollte vor dem Eindringen von Flüssigkeiten sowie vor Regen, Schnee etc. geschützt werden. Bei Standortänderung von kalter in wärmere Umgebung sollte das Gerät wegen der Kondensation erst nach Anpassung an die wärmere Umgebung mit dem Netz verbunden werden. Das Gerät darf nur in Umgebungsbedingungen wie im Datenblatt beschrieben, betrieben werden; ansonsten wird der vom Gerät vorgesehene Schutz des Anwenders beeinträchtigt.

Dieses Produkt ist nicht für den Einsatz in gefährlicher Umgebung (z.B. Ex-Bereich) und für medizinische Anwendungen geprüft. Sollte das Gerät für den Einsatz in sicherheitsrelevanten Anwendungen wie z.B. im Flugverkehr oder bei militärischen Anwendungen vorgesehen sein, so ist dieser von einer für diesen Bereich zuständigen Person zu beurteilen und genehmigen.

WARNING



Elektrische Schläge (Gleichspannungsversorgung)

Dieses Gerät entspricht der IEC Sicherheitsklasse III. Aus Sicherheitsgründen darf es nur an Netzgeräte und Signalquellen angeschlossen werden, die in Spannung und Isolation der SELV und SELV-E Richtlinie genügen ("Getrennte Niederspannung"). Im Gerät werden keine gefährlichen Spannungen erzeugt. Im Datenblatt werden die anschließbaren Höchstspannungen definiert.

Öffnen Sie niemals das Gehäuse der Geräte das dies zu ernsthaften Verletzungen führen kann. Es gibt keine vom Anwender austauschbare Teile in diesem Gerät.

WARNING



Warnung vor giftigen Substanzen

In einigen Bauelementen dieses Geräts können Epoxyharze oder andere Materialien enthalten sein, die im Brandfall giftige Gase erzeugen. Bei der Entsorgung müssen deshalb entsprechende Vorsichtsmaßnahmen getroffen werden.

WARNING



Beryllium Kupfer

Es ist möglich, dass in diesem Gerät sind einige mechanische Komponenten aus Beryllium Kupfer gefertigt. Dies ist eine Verbindung welche aus einem Berylliumanteil von ca. 5 % besteht. Bei normaler Verwendung besteht kein Gesundheitsrisiko.

Das Metall darf nicht bearbeitet, geschweißt oder sonstiger Wärmebehandlung ausgesetzt werden.

Es muß als Sondermüll entsorgt werden.

Es darf nicht durch Verbrennung entsorgt werden.

CAUTION

Eignung für Gebrauch

Dieses Gerät wurde von Aeroflex entwickelt und hergestellt um HF Signale geringer Leistung zum Test von Kommunikationseinrichtungen zu erzeugen und HF Signale zu digitalisieren und Spektrumanalyse an HF Signalen durchzuführen.

Sollte das Gerät nicht auf die von Aeroflex vorgesehene Art und Weise verwendet werden, kann die Schutzfunktion des Gerätes beeinträchtigt werden.

Aeroflex hat keinen Einfluß auf die Art der Verwendung und übernimmt keinerlei Verantwortung bei unsachgemässer Handhabung.

Precauzioni

WARNING**CAUTION****Note**

Questi termini vengono utilizzati in questo manuale con significati specifici:

WARNING

riportano informazioni atte ad evitare possibili pericoli alla persona.

CAUTION

riportano informazioni per evitare possibili pericoli all'apparecchiatura.

Note

riportano importanti informazioni di carattere generale.

Simboli di pericolo

Il significato del simbolo di pericolo riportato sugli strumenti e nella documentazione è il seguente:

Simbolo**Tipo di pericolo**

Fare riferimento al manuale operativo quando questo simbolo è riportato sullo strumento. Rendervi conto della natura del pericolo e delle precauzioni che dovrete prendere.



Tensione pericolosa



Pericolo sostanze tossiche

Condizioni generali d'uso

Questo prodotto è stato progettato e collaudato per rispondere ai requisiti della direttiva IEC/EN61010-1 'Safety requirements for electrical equipment for measurement, control and laboratory use' per apparati di classe III, per l'uso in un ambiente inquinato di grado 2. L'apparato è stato progettato per essere alimentato da un alimentatore di categoria I.

Lo strumento deve essere protetto dal possibile ingresso di liquidi quali, ad es., acqua, pioggia, neve, ecc. Qualora lo strumento venga portato da un ambiente freddo ad uno caldo, è importante lasciare che la temperatura all'interno dello strumento si stabilizzi prima di alimentarlo per evitare formazione di condense. Lo strumento deve essere utilizzato esclusivamente nelle condizioni ambientali descritte nella scheda tecnica, in caso contrario le protezioni previste nello strumento potrebbero risultare non sufficienti.

Questo prodotto non è stato approvato per essere usato in ambienti pericolosi o applicazioni medicali. Se lo strumento deve essere usato per applicazioni particolari collegate alla sicurezza (per esempio applicazioni militari o avioniche), occorre che una persona o un istituto competente ne certifichi l'uso.

WARNING



Pericoli da elettricità (alimentazione a c.c.)

Questo strumento rispetta le norme IEC, classe III, e quindi, per una completa sicurezza, deve essere collegato solo ad alimentatori e generatori di segnali che rispettano i requisiti di tensione ed isolamento SELV e SELV-E (Separated Extra-Low Voltage). Nessuna tensione pericolosa è generata al suo interno. Vedi la scheda tecnica per quanto concerne i livelli massimi di tensione applicabili.

Non rimuovete mai le coperture perché così potreste provocare danni a voi stessi. Non vi sono all'interno parti di interesse all'utilizzatore.

Tutte gli interventi sono di competenza del personale qualificato. Vedi elenco internazionale dei Centri di Assistenza in fondo al manuale.

WARNING



Pericolo sostanze tossiche

Alcuni dei componenti usati in questo strumento possono contenere resine o altri materiali che, se bruciati, possono emettere fumi tossici. Prendere quindi le opportune precauzioni nell'uso di tali parti.

WARNING



Rame berillio

E' possibile que alcuni componenti meccanici in questo strumento sono realizzati in rame berillio. Si tratta di una lega con contenuto di berillio di circa il 5%, che non presenta alcun rischio in usi normali.

Questo materiale non deve essere lavorato, saldato o subire qualsiasi processo che coinvolge alte temperature.

Deve essere eliminato come "rifiuto speciale". Non deve essere eliminato tramite "inceneritore".

CAUTION

Caratteristiche d'uso

Questo strumento è stato progettato e prodotto da Aeroflex generare segnali RF in bassa potenza per provare apparati di radio comunicazione e digitalizzare ed eseguire analisi di spettro su segnali RF.

Se lo strumento non è utilizzato nel modo specificato da Aeroflex, le protezioni previste sullo strumento potrebbero risultare inefficaci.

Aeroflex non può avere il controllo sull'uso di questo strumento e non può essere ritenuta responsabile per eventi risultanti da un uso diverso dallo scopo prefisso.

Precauciones

WARNING

CAUTION

Note

Estos términos tienen significados específicos en este manual:

WARNING

contienen información referente a prevención de daños personales.

CAUTION

contienen información referente a prevención de daños en equipos.

Note

contienen información general importante.

Símbolos de peligro

El significado de los símbolos de peligro en el equipo y en la documentación es el siguiente:

Símbolo

Naturaleza del peligro



Vea el manual de funcionamiento cuando este símbolo aparezca en el instrumento. Familiarícese con la naturaleza del riesgo y con las acciones que deban de tomarse.



Voltaje peligroso



Aviso de toxicidad

Condiciones generales de uso

Este producto ha sido diseñado y probado para cumplir los requerimientos de la normativa IEC/EN61010-1 “Requerimientos de la normativa para equipos eléctricos de medida, control y uso en laboratorio”, para equipos clase III, para uso en un ambiente con un grado de contaminación 2. El equipo ha sido diseñado para funcionar sobre una instalación de alimentación de categorías I.

Debe protegerse el equipo de la entrada de líquidos y precipitaciones como nieve, lluvia, etc. Cuando se traslada el equipo de entorno frío a un entorno caliente, es importante aguardar la estabilización del equipo para evitar la condensación. Solamente debe utilizarse el equipo bajo las condiciones ambientales especificadas en la Hoja Técnica, en caso contrario la propia protección del equipo puede resultar dañada.

Este producto no ha sido aprobado para su utilización en entornos peligrosos o en aplicaciones médicas. Si se va a utilizar el equipo en una aplicación con implicaciones en cuanto a seguridad, como por ejemplo aplicaciones de aviónica o militares, es preciso que un experto competente en materia de seguridad apruebe su uso.

WARNING



Nivel peligroso de electricidad (tensión de alimentación DC)

Este equipo cumple con la norma de seguridad IEC clase III, lo que significa que para total seguridad debe ser conectado a alimentaciones y fuentes de señal que cumplan los requerimientos de tensión y aislamiento “Tensión Separada Extra-Baja” (SELV y SELV-E). Ninguna tensión generada internamente implica riesgo para el operario.

En la Hoja Técnica podrá encontrar los valores máximos permitidos que pueden aplicarse.

No retire las cubiertas del chasis del instrumento, ya que pudiera resultar dañado personalmente. No existen partes que puedan ser reparadas en su interior.

Deje todas las tareas relativas a reparación a un servicio técnico cualificado. Vea la lista de Centros de Servicios Internacionales en la parte trasera del manual.

WARNING



Aviso de toxicidad

Alguno de los componentes utilizados en este equipo pudieran incluir resinas u otro tipo de materiales que al arder produjeran sustancias tóxicas. Por tanto, tome las debidas precauciones en la manipulación de esas piezas.

WARNING



Berilio-cobre

Es posible que algunos componentes mecánicos contenidos en este instrumento incorporan berilio-cobre en su proceso de fabricación. Se trata de una aleación con un contenido aproximado de berilio del 5%, lo que no representa ningún riesgo durante su uso normal.

El material no debe ser manipulado, soldado, ni sometido a ningún proceso que implique la aplicación de calor.

Para su eliminación debe tratarse como un "residuo especial". El material **NO DEBE** eliminarse mediante incineración.

CAUTION

Idoneidad de uso

Este equipo ha sido diseñado y fabricado por Aeroflex para generar señales de VHF y UHF de bajo nivel de potencia para prueba de equipos de radiocomunicaciones y para digitalizar y realizar análisis espectral de señales RF.

Si el equipo fuese utilizado de forma diferente a la especificada por Aeroflex, la protección ofrecida por el equipo pudiera quedar reducida.

Aeroflex no tiene control sobre el uso de este equipo y no puede, por tanto, exigirse responsabilidades derivadas de una utilización distinta de aquellas para las que ha sido diseñado.

Installing a 3000 Series PXI module

Introduction

This guide explains how to install and configure your Aeroflex 3000 Series PXI module.

More detailed information about the module, how to operate it and how it works, is given in the relevant Operating Manual. This is a PDF document on the PXI Modules CD-ROM packaged with your module (see [here](#) for details), which is installed by default to *C:\VXIPNP\WinNT\af30xx* when you carry out the [software installation](#).

Please read the cautions and instructions below before installing the module into the PXI chassis.

Naming conventions

'3000 Series' is the generic name for any Aeroflex PXI module.

'3010 Series' includes 3010 and 3011 RF synthesizer modules.

'3020 Series' includes 3020, 3020A, 3020C, 3025 and 3025C RF synthesizer modules.

'3030 Series' includes 3030, 3030A, 3030C, 3035 and 3035C RF digitizer modules.

'3060 Series' includes 3060 and 3065 RF combiner modules.

Unpacking the module

Contents of packing

- 3000 Series module
- PXI Modules CD-ROM part number 46886/028, containing:
 - software installer
 - drivers and soft front panels, including FFT spectrum analysis library
 - Common Installation Guide (this document)
 - Installation Guide for Chassis
 - operating manuals for all 3000 Series PXI modules
 - application software, including RF Investigator, PXI Studio
 - PXI version information software
 - product specifications.
- Module test results CD-ROM part number 46886/054.
- Link cable(s)

Handling precautions

Do not remove the module from its protective packaging until you are ready to insert it into the chassis.

Avoid static damage by wearing a wrist strap or by touching a good ground frequently whilst handling the module.

Be especially careful not to touch connectors.

DO NOT insert or remove a module while the chassis is powered up — the module will probably be damaged.

WARNING

Initial visual check

After unpacking the module, inspect the packaging for any signs of damage. If there is damage, keep the packaging for examination by the carrier in the event that a claim is made. Examine the module for signs of damage, especially to the items shown in Fig. 1. Do not install a suspect module, as internal electrical damage could result in a fire.

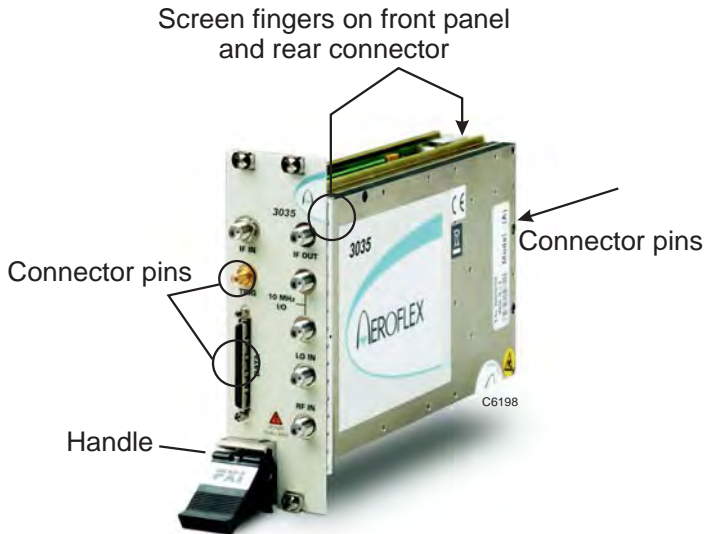

Fig. 1 Checking a module for damage

Typical system

- PXI chassis, for example Aeroflex 3000/3000A 3U chassis
- PCI-to-PXI interface kit and a PC running Windows 2000 or XP or
PXI embedded controller, for example Aeroflex 3001A running
Windows 2000 or XP
- Aeroflex PXI module(s): 3010 Series RF synthesizer, 3020 Series RF
signal generator, 3030 Series RF digitizer, 3060 Series RF combiner.

System requirements

The following is the recommended minimum PC specification that should be used with Aeroflex PXI hardware and software products:

Intel Pentium III — 800 MHz or better

Vacant PXI expansion slot, supporting bus mastering when using PCI-PXI interface kit.

512 MB RAM (for 8-slot PXI chassis — larger PXI chassis may require more memory to be fitted)

200 MB free disk space

1024 X 768 display resolution

USB CD-ROM drive or network access for software installation

Microsoft Windows XP Professional with Service Pack 1

Microsoft Windows 2000 with Service Pack 4

National Instruments NI-VISA — V3.1.0 or later.

Tools required

Flat-bladed screwdriver 3 mm

Posidriv screwdriver size 0

Torque wrench — see [torque settings](#)

Software architecture

Fig. 2 shows the relationship between user applications and their relevant dlls. Below this level, Fig. 3 shows the relationship between the PXI modules, their driver software, DLLs, COM and CPP interfaces.

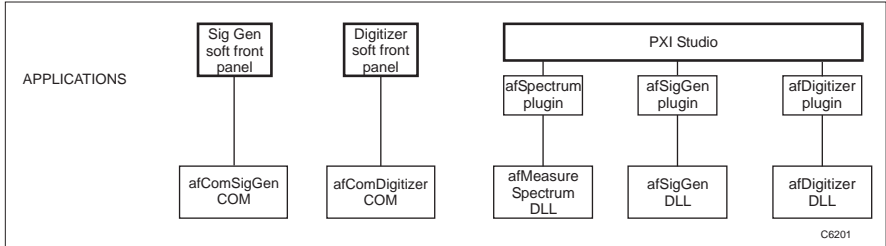

Fig. 2 Software structure: applications

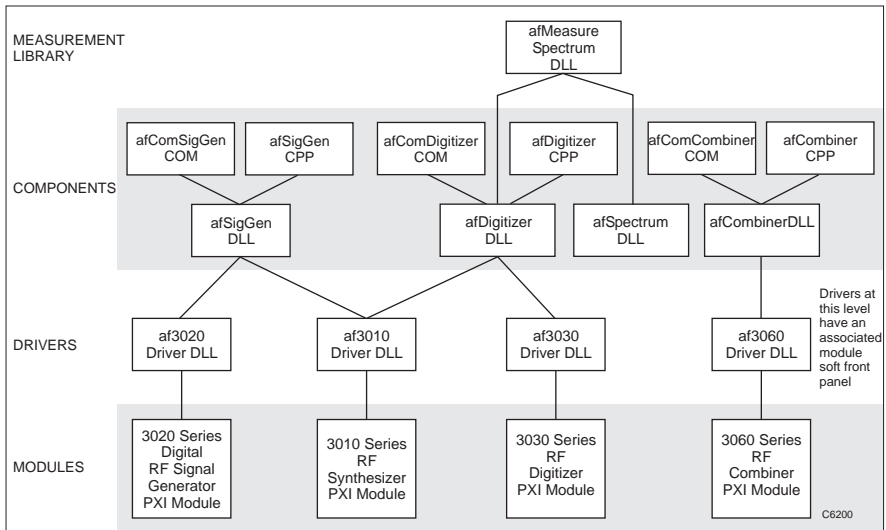

Fig. 3 Software structure: libraries

Which interface to use?

The COM, CPP and DLL interfaces (for example, afComSigGen, afSigGenCPP and afSigGenDLL) provide common functionality and a consistent application programming interface (API).

Use whichever interface is most appropriate to your application.

This guide explains how to install modules, drivers and components.

Installation process

General

In its default mode, the supplied PXI module software installer automatically installs the following software drivers and instrument components:

<p style="text-align: center;">PXI module drivers</p> <p>3010 Series PXI RF Synthesizer Driver 3020 Series PXI RF Signal Generator Driver 3020 Series PXI RF Digitizer Driver 3060 Series PXI RF Combiner Driver</p> <p style="text-align: center;">PXI module documentation</p> <p>3010 Series Documentation 3020 Series Documentation 3030 Series Documentation 3060 Series Documentation</p> <p style="text-align: center;">PXI instrument components</p> <p>Combiner Digitizer Signal Generator Spectrum Analysis Components RF Investigator</p>

Note: earlier versions of the installer installed these drivers and components individually.

Module drivers

Module drivers provide an interface between the low-level instructions understood by the instrument and higher-level instructions that are easier for a programmer to use and understand. The drivers conform to the VXIplug&play and LabWindows/CVI standards and are contained in a DLL (dynamic link library). The drivers are also provided as source code.

Instrument components

The instrument components that are installed by the PXI module software installer are structured as follows:

RF digitizer comprises: afDigitizer Component Library
(afDigitizerDLL (C library interface),
afComDigitizer (Microsoft COM component),
afDigitizerCPP (C++ Class interface)),
associated soft front panel application.

RF signal generator
comprises: afSigGen Component Library
(afSigGenDLL (C library interface),
afComSigGen (Microsoft COM component),
afSigGenCPP (C++ Class interface)),
associated soft front panel application.

RF combiner comprises: afCombiner Component Library
(afCombinerDLL (C library interface),
afComCombiner (Microsoft COM
component),
afCombinerCPP (C++ Class interface)).

Spectrum analysis component
comprises: afSpectrum DLL.

RF Investigator: an easy-to-use application providing a single
environment for controlling the Digitizer,
SigGen and RF Combiner software controls.
It provides spectrum analysis functions
including adjacent channel power and
occupied bandwidth. You can save displayed
graph data and 'raw' captured IQ data to file.

Aeroflex PXI Version Info: a utility to report versions of Aeroflex PXI-
related drivers and applications.

PXI Studio and measurement suites

PXI Studio, and instrument components for measurement suites (for example, afGsm) that are purchased and supplied additionally, need to be installed [separately](#).

Order of installation

- 1 Install PXI module software: see [Installing PXI module software](#).
- 2 Then install any additionally-purchased application software: see [Installing application software packages](#).
- 3 Follow this with [Hardware installation](#).

Uninstalling PXI module software

If your system has Aeroflex PXI module software installed from an older style installer kit (prior to version 5.0.0 of the installer), we strongly recommend that you remove any of the existing components from the installation using Add/Remove Programs from the Control Panel.

You can determine if such software installations exist by checking to see if Add/Remove Programs lists any of the following:

- Af3010
- Af3020
- Af3020
- Af3060
- Aeroflex RF Combiner Components
- Aeroflex RF Combiner Control
- Aeroflex RF Digitizer Components
- Aeroflex RF Digitizer Control
- Aeroflex RF Digitizer Soft Front Panel
- Aeroflex RF SigGen Components
- Aeroflex RF SigGen Control
- Aeroflex RF SigGen Soft Front Panel
- Aeroflex Spectrum Analysis
- Aeroflex RF Investigator

In this case, use Add/Remove Programs from the Control Panel to uninstall the particular item (see below).

Removing previous versions of application software

- Open the Control Panel (Start\Settings\Control Panel)
- Select Add/Remove Programs
- Select the previous version of the component or complete module software being installed (for example, Aeroflex RF SigGen Control (VX.X.X)), and click the 'Change/Remove' button next to it.

Driver version

To maintain optimum performance, all 3000 Series PXI modules should be used either with the software driver version with which they were supplied (on the Aeroflex 3000 Series PXI Modules CD-ROM part no. 46886/028), or the latest driver, which you can download from the Aeroflex website.

Aeroflex endeavours to ensure modules remain backwards compatible with earlier driver version releases.

However, continual improvement means that from software version **6.2.0** onwards there are exceptions, which are explained below.

Checking the software compatibility of a PXI module

- Modules that are compatible with all driver versions display on their front panel a serial number label consisting of black lettering on a **white** background.
- Modules that are only compatible with software driver installation version 6.2.0 and higher have a serial number label consisting of black lettering on a **yellow** background.

White background to label
use all driver s/w versions

Yellow background to label
use v. 6.2.0 s/w or higher

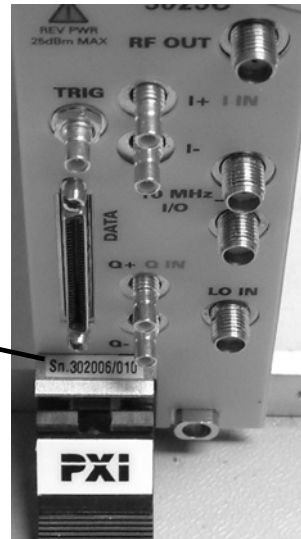

Fig. 4 Location of serial no. label (example)

Please ensure that you install the correct version of software for your module.

Installing PXI module software

These instructions for installing software apply both to PXI embedded controllers and PCs with PCI-to-PXI interface kits.

Installation locations

Driver files, soft front panels and help files are installed to the VXIPNP folder appropriate to your operating system. For example, for Windows XP, the installation folder should be *C:\VXIPNP\WinNT\af30xx* (where C: is your hard drive designation and 30xx is the model number of your module).

Software components are installed to *C:\Program Files\Aeroflex*.

Installation procedure

- Insert the PXI Module Software CD-ROM.

The *PXIModuleSoftware_vX_Y_Z_setup.exe* installer executable should auto-run.

If it does not auto-run, open the CD-ROM in an Explorer window and double-click on *PXIModuleSoftware_vX_Y_Z_setup.exe*.

Initially the following popup appears, indicating that the system is preparing to install the PXI Module Software.

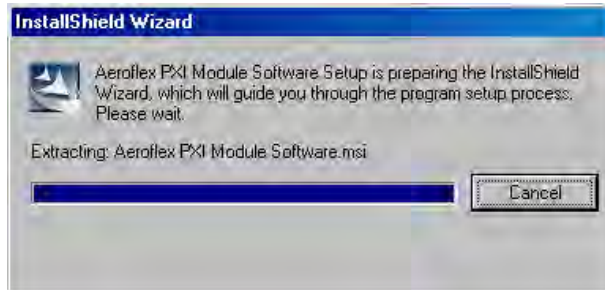

The following Welcome panel appears.

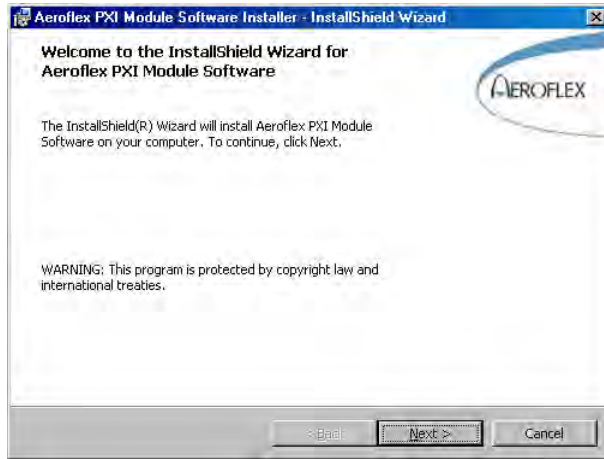

- Click **N**ext> to continue the installation.

The next panel asks you to ensure that you uninstall all Aeroflex PXI Module software that has been installed by an installer earlier than version 5.0.0.

- If earlier versions do exist, use Add/Remove Programs from the Control Panel to uninstall these particular items.

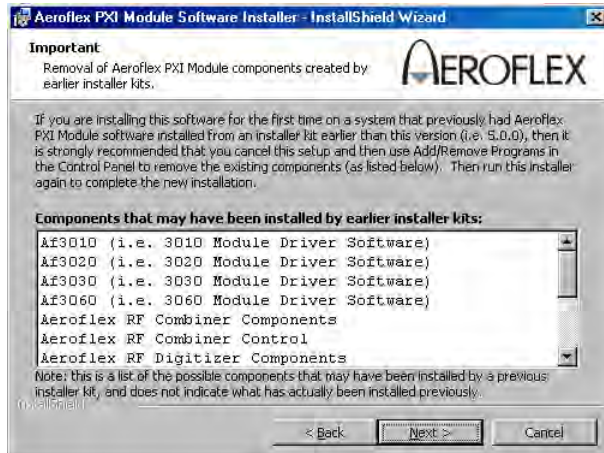

- The next panel presents the license agreement. In order to proceed with the installation, you must accept the agreement.



- Click Next to continue with the installation.

You are now presented with a choice of Complete or Custom setup. The Complete setup ensures that all Aeroflex PXI Module software components are installed; the Custom setup allows you to install a subset.

If you are an advanced user, you may choose to select the Custom setup to do a partial install, but you need to be aware of the dependencies between the different components that may be installed. For this reason, we recommend that most users select the Complete setup.

- Click on the appropriate radio button.

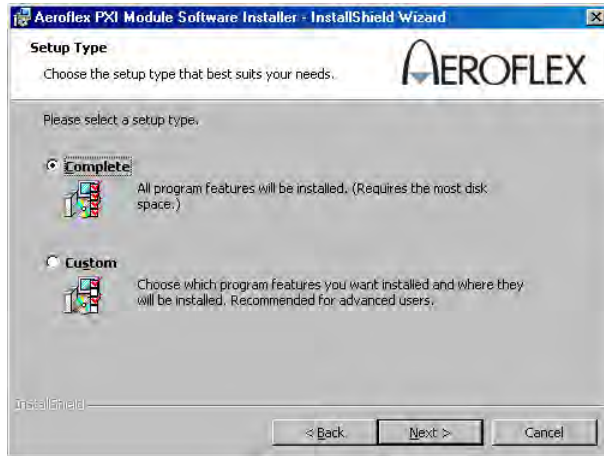

- Click Next> to continue with the installation.

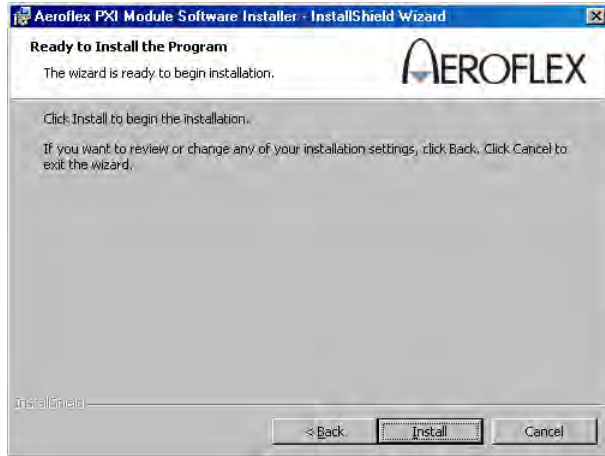

- Click Install to begin the installation...

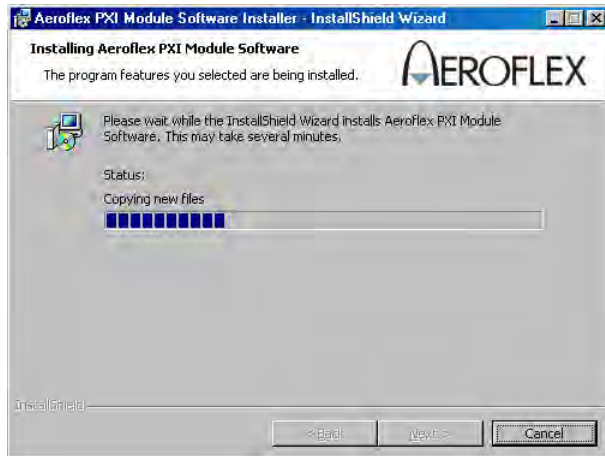

- ...and wait for the software to install.

Upon completion of the installation, the following panel is displayed.

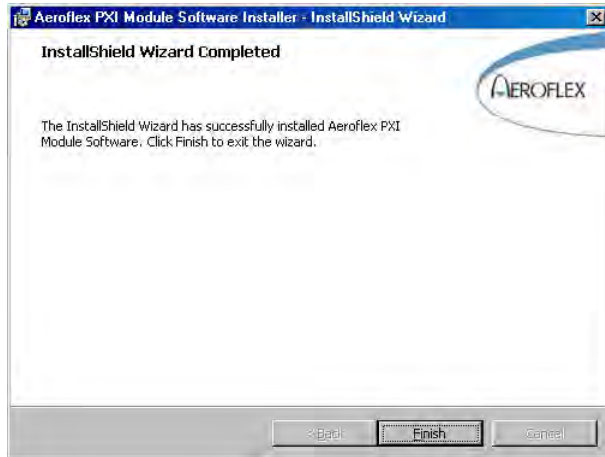

- Click **Finish** to complete the installation.

The Aeroflex PXI Module Software is now be completely installed and ready to use. See [Using the installed software](#).

- If you have purchased [additional application software](#), install it now.
- You are then ready to perform the [hardware installation](#).

Installing PXI Studio application software

A separate installer is provided on the CD-ROM module that installs the application. Refer to the PXI Studio User Guide 46892/809 for details of this application.

Installing additional application software packages

If you have purchased a separate measurement suite (for example, afGsm), install it from its own CD-ROM.

If it is an upgrade to a previous version, use Add/Remove Programs on the Control Panel to [remove](#) the previous version first.

Installing chassis and controller software

Refer to the documentation supplied with the chassis. For an Aeroflex 3000 Series chassis, this is the User Guide, part no. 46892/837.

Hardware installation

Check the safety documentation

Read the safety and installation instructions that accompany the chassis and embedded controller or PCI-to-PXI interface.

CAUTION

ALWAYS POWER DOWN THE CHASSIS BEFORE INSERTING OR REMOVING ANY AEROFLEX 3000 SERIES PXI MODULE.

Installing the 3000 Series module into the chassis

Remind yourself of the [Handling precautions](#).

- 1 Disconnect the power cord.
- 2 Touch an earthed metal object to discharge any static electricity on your body or clothes.

Remove the module from its packaging.

Remove rubber sleeves from the captive screws on the module.

- 3 Turn the ejector handle on the module to point downwards
- 4 Slide the module carefully into its slot by pressing on the ejector handle. You can install the module in any slot in the chassis except slot 1. Check that EMC gasket fingers (behind the front panel) are in contact with adjoining units.
- 5 When you feel the handle engage with the chassis, rotate it upwards. This seats the module onto its connectors and locks it into the chassis.
- 6 Tighten the captive screws on the module to attach it to the chassis.

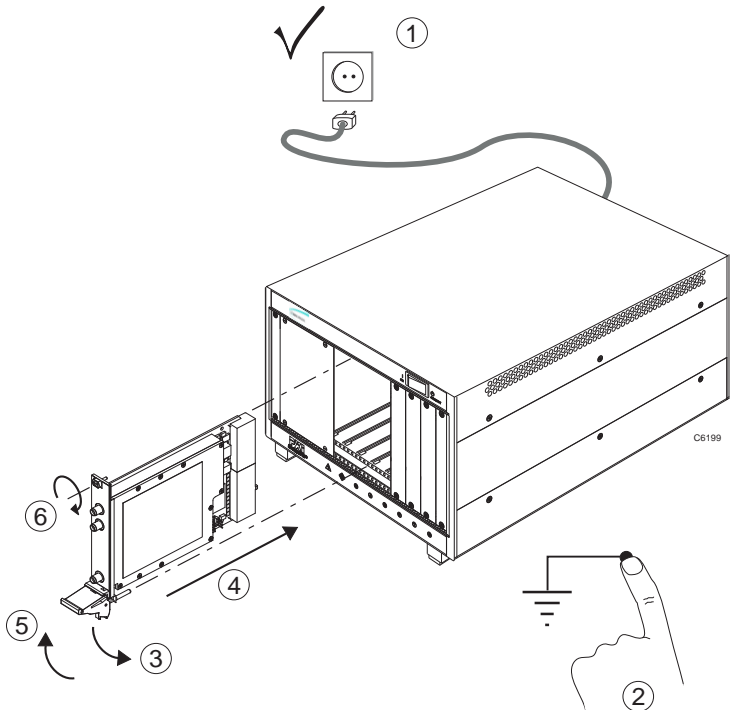

Fig. 5 Installing module into chassis (this procedure applies to any module)

Connecting and torquing SMA connectors

- 1 First, ensure that the mating halves of the connector are correctly aligned.
- 2 Next, engage the threads of the nut and tighten it by hand, ensuring that the mating halves do not move relative to each other.
- 3 Then use a torque spanner to tighten the connector, in order to ensure consistent matching and to avoid mechanical stress.

Torque settings for connectors are:

0.56 Nm test torque (development use, semi-permanent installations)

1 Nm final torque (permanent installations)

Never use pliers to tighten connectors.

For PCI-to-PXI interface kit users

- 1 Ensure the interface is installed according to the manufacturer's instructions. You need a vacant PXI expansion slot that supports bus mastering when using a PCI-PXI interface kit.
- 2 Ensure that the module's [driver software](#) (and instrument component software, if required) is installed.
- 3 Connect the PXI chassis to the PC using the PCI-to-PXI interconnection cable supplied.
- 4 You are now ready to power up the PXI chassis. Power up the PXI chassis before the PC.
- 5 Depending upon which Windows operating system you are using, go to the appropriate section below ([For Windows NT users](#) or [For Windows 2000, Me, XP users](#)).

For PXI embedded controller users

- 1 Ensure that the module's [driver software](#) is installed.
- 2 Once you have installed the module you are ready to power up the PXI chassis.
- 3 Depending upon which Windows operating system you are using, go to the appropriate section below ([For Windows NT users](#) or [For Windows 2000, Me, XP users](#)).

For Windows NT users

If you are using Windows NT, browse in Windows Explorer to the INF file in the folder where you installed it earlier (for example, *C:\VXI\PNP\WinNT\af3010\af3010_NT4.INF*), then right-click on it and select **I**nstall.

The install process for the INF file then takes a few seconds and is automatic.

Finally, reboot the computer.

The installation of your PXI module is now complete. Now go to

[Using the Installed Software](#).

For Windows 2000, Me, XP users

If you are using Windows 2000, Me or XP, Windows indicates that it has found new hardware after powering up the PXI chassis and PC. Please note that the exact window that appears during this process may differ depending upon the Windows operating system you are using. These examples are for the 3030 RF Digitizer; they are similar for all 3000 Series modules.

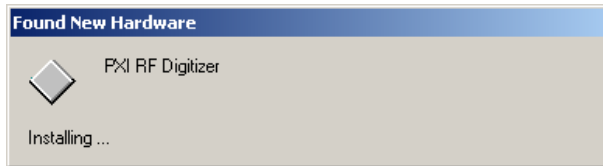

- When the following window appears, press **N**ext> to continue with the hardware installation.



- The following window appears. Select Search for a suitable driver for my device (recommended), and then press Next>.



- When the next window appears, select Specify a location and then press Next>.

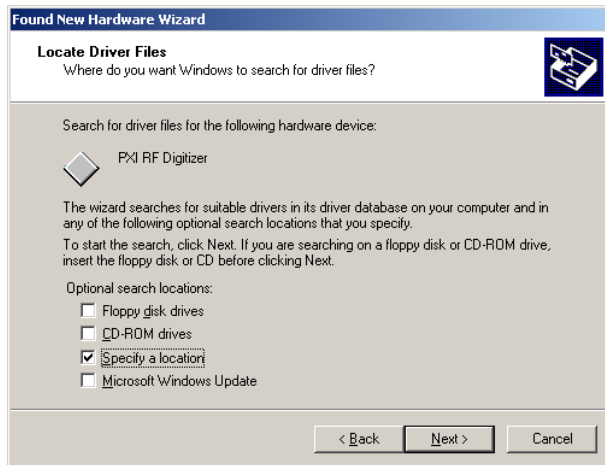

- At the next window, select the appropriate location from which to copy the device driver files. This will be the location to which the INF file was installed during the software installation — for example, `C:\VXIPNP\WINNT\AF3030`.



- The next window indicates that the device driver has been found. To accept this driver, press **N**ext>.

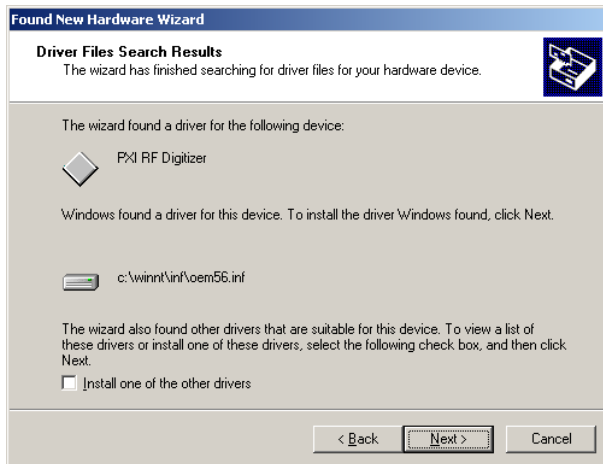

- The following window indicates that the hardware installation has completed, at which point you should press the Finish button.

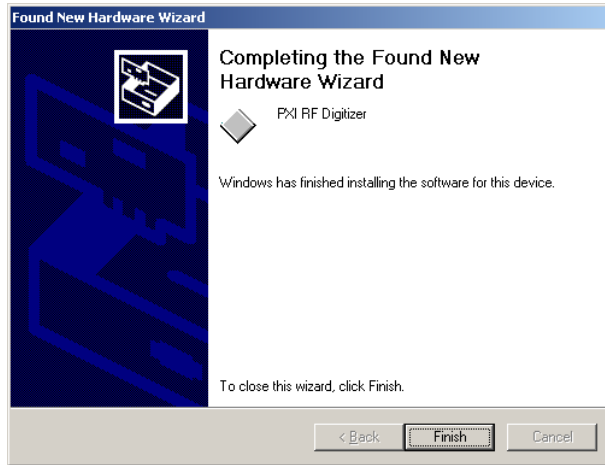

Removing the module

- 1 Disconnect the power cord.
- 2 Loosen off the captive screws on the module.
- 3 Turn the ejector handle downwards. If you meet resistance, check that the captive screws are free of the tappings in the chassis. Do not force the handle.
- 4 Slide the module carefully from the chassis. If possible, put it back into its protective packaging.

Connector maintenance

Clean connectors regularly, using a cotton bud dipped in isopropyl alcohol. Wipe all accessible surfaces, then use a dry cotton bud to finish off. Check for any deposits.

Do not use other cleaners, as they can cause damage to the plastic insulators within the connectors.

Cap unused connectors.

See [here](#) for important information on correct connector handling.

Using the installed software

Following installation, and after rebooting the PC, you are ready to access the PXI drivers, soft front panel and documentation.

Running the soft front panel

- With National Instruments Measurement and Automation Explorer (MAX) installed on your PC, you can access the PXI module's soft front panel from there, by selecting Tools\Soft Front Panels from that program's menu bar.

The soft front panel appears in the menu as (for example) *AF3010_SFP - AF3010 Soft Panel*.

- You can also access the soft front panel from the Windows Start menu under Programs\Aeroflex\PXI Module Front Panels\AF30x0 Front Panel.

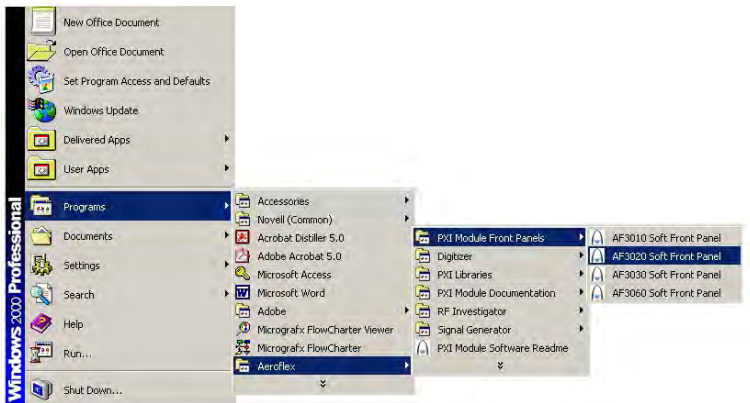

- You can also run the soft front panel from Windows Explorer, by creating a shortcut on the Windows Desktop.

Locate the soft front panel executable in the driver installation folder as specified earlier in the driver installation process (for example, the 3010 Series soft front panel executable should be in *C:\VXIPNP\WinNT\af3010* or similar, and is named *af3010_sfp.exe*).

Now create a shortcut of this executable on the desktop or run it directly from this folder location.

Operating manuals

There is a separate operating manual for each 3000 Series module. Each manual contains information about installing, connecting and operating the module, an explanation of the soft front panel, and a technical description. All the operating manuals are included on the PXI Modules CD-ROM, part no. 46886/028, and are installed by the installer to:

Start\Programs\Aeroflex\PXI Module Documentation

and to the appropriate module folder

C:\VXIPNP\WINNT\af3010, ... \af3020, ... \af3030, ... \af3060.

Contents of installation folder

In addition to the soft front panel executable program, the installation folder contains other files. The key files are:

<i>af0xx_RT.inf</i>	LabVIEW Real Time INF file	
<i>af30xx_9x.inf</i>	Windows 9x INF file	
<i>af30xx_NT4.inf</i>	Windows NT4 INF file	
<i>af30xx_NT5.inf</i>	Windows 2000/XP INF file	
<i>af30xx_sfp.exe</i>	30xx soft front panel program	
<i>af30xx.c</i>	30xx driver LabWindows/CVI source code	
<i>af30xx.fp</i>	30xx LabWindows/CVI function panel file	
<i>af30xx.doc</i>	30xx function documentation	
<i>af30xx.hlp</i>	30xx Visual BASIC function reference	} Windows Help file format
<i>af30xx_C.hlp</i>	30xx C language function reference	
<i>af30xx.h</i>	30xx driver LabWindows/CVI header file	} Installed into C:\VXIIPnP\WinNT\include (or similar)
<i>af30xx_const.h</i>	30xx driver constant definitions header file	
	Other support files are installed in C:\VXIIPnP\WinNT\lib (or similar) and C:\VXIIPnP\WinNT\bin (or similar)	

Other installed items

Other items that are installed by the PXI module software installer include RF Digitizer and RF Signal Generator soft front panels, **IQCreator**[®] waveform creation software and PXI Libraries. Documentation and/or help for these items is included in the installation.

Identifying modules installed in a chassis

National Instruments Measurement and Automation Explorer (MAX) is installed automatically when you install National Instruments hardware drivers or development environments.

MAX allows you to identify modules by their resource string:

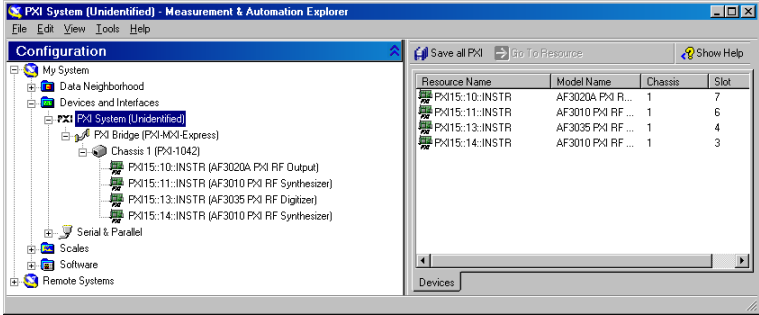

or by their slot number in the chassis:

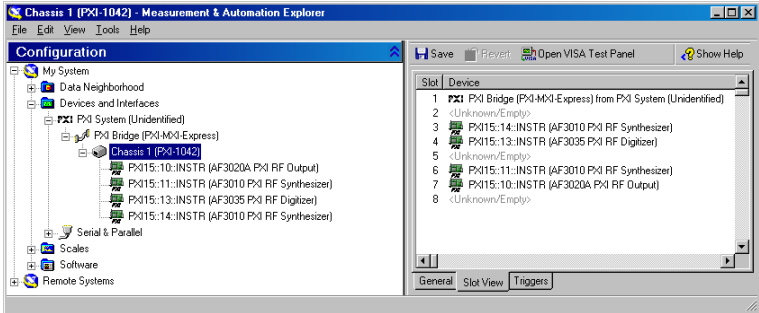

Further information and options are available by right-clicking on individual instruments. Drop-down lists allow you to identify the chassis and other components that you are using.

Further information

Refer to National Instruments MAX documentation for further information on this useful tool. Go to the Help menu in MAX and open the *Measurement & Automation Explorer Help for PXI* by navigating to Help Topics\PXI. Find setup information under the entry *PXI System Configuration*.

The Aeroflex *Installation Guide for Chassis* (document no. 46892/667) is supplied with each chassis on the PXI Modules CD-ROM, part no. 46886/028. It provides an overview of a typical configured PXI system (comprising Aeroflex modules installed in a PXI chassis, together with a PXI controller, drivers and application software) and explains how to set up a populated chassis ready for use.

Repackaging

If you need to return a module or chassis to us, please observe the following points:

Tagging

Tag the returned item(s) with:

- your name and address
- the nature of the repair needed
- the type, model number and serial number.

Shipping containers

Repackage the items in their original container and packing material. If the original shipping containers and materials are not available, contact Customer Service Department for shipping instructions.

Freight costs

See 'Warranty Packet' for freight charge policy on warranty claims. Freight costs on shipments out of warranty are borne by the customer.

Repacking procedure

If the original container or materials are not available, use a strong double-walled carton packed with a 7 to 10 cm (3 to 4 inch) layer of shock-absorbing material around all sides of the module or chassis to hold it firmly. Protect the front panel with a plywood or cardboard load-spreader. A rear load-spreader is also advisable.

Your labels

It may be necessary for us to cut or remove labels that you have attached to the module if they impede access to its interior.