

12 Channel Device Power Supply Card (DPS12)



Overview

The 12 channel Device Power Supply (DPS12) is an AXIe 3.1 compliant instrument board. Each DPS12 board is organized as two banks of six channels.

Bank 1 - Channels 1-6

Bank 2 - Channels 7-12

Refer to Figure 1-1 and Figure 1-2. Each Bank operates in one of three selectable modes (Positive, Bipolar, or Negative) with the following ranges:

Positive 0 V to +22.0 V @ current ranges below 500 mA

0 V to +6.0 V @ current range 1.2 A

Bipolar (default) -12.0 V to +12.0 V @ current ranges below 500 mA

-6 V to +6 V @ current range 1.2 A

Negative -20.0 V to 0 V @ current ranges below 500 mA

-6 V to 0 V @ current range 1.2 A

Each channel may be operated in any one of six current ranges, independently. Bank current usage is limited to 7.2A max per Bank with a total channel current of 12A per DPS12 board as shown in Section 3.1.

Each channel has the following capability:

- Force Voltage and Measure Current (FVMI), Force Voltage and Measure Voltage (FVMV), or Force Nothing and Measure Voltage (FNMV)
- 4-pin Kelvin connection, including active guard
- Programmable voltage ramp
- Programmable current clamps
- Window comparator for fast, go/no-go testing of voltage or current
- Programmable load compensation to maximize supply stability
- Alarms: Kelvin high, kelvin low, guard short, current clamps, temperature
- 6 Current ranges: 25 uA, 250 uA, 2.5 mA, 25 mA, 500 mA, 1.2 A
- Adjacent channel ganging is supported on the upper 3 current ranges allowing up to 2.4As per channel pair.
- Parametric Measurement Unit (PMU) digitization of voltage or current is supported on all channels utilizing a 32 M sample shared memory at data rates up to 200 Ksps.
- PMU digitization can be triggered from any one of four AXIe 3.1 compliant DSTAR trigger sources or PMU digitization measurements may be clocked from any one of four DSTAR trigger sources.
- Force pattern capability for any combination of channels utilizing 32 M memory for programmable voltages and dwell times. Triggerable via DSTAR trigger sources.

Typical applications of the DPS12 are:

1. Characterization and validation
2. Multi-site automated production test
3. Leakage current measurement
4. Continuity measurement
5. Multi-channel voltmeter
6. I-V curve measurement

1.1 Environmental

Ambient operating conditions: 20°C to 30°C

Operating humidity: 30% to 60% humidity non-condensing

Instrument calibration: Valid for 30 days within ±5°C ambient operation conditions

1.2 Channel Count

The minimum system configuration is 12 channels, expandable in 12 channel increments.

2 Channel Specifications

Each DPS12 board is organized as two banks of six channels.

Bank 1 - Channels 1-6

Bank 2 - Channels 7-12

Each Bank operates in one of three modes: Positive, bipolar or negative. Each channel has per pin resources for levels and current ranges as shown in the tables below.

Note:

1. *Subject to bank and board power limitations. See Section 3.1.

2.1 Force Voltage Ranges

	Voltage Range		Current Range*	Resolution	Accuracy
2.1.1.1	Bipolar (default)	-12.0 V to +12.0 V	±500 mA ±25 mA ±2.5 mA ±250 µA ±25 µA	0.38 mV	±(0.05% of value + 12.5 mV)
2.1.1.2		-6.0 V to +6.0 V	±1200 mA	0.38 mV	±(0.05% of value + 12.5 mV)
2.1.1.3	Positive	0 V to 22.0 V	±500 mA ±25 mA ±2.5 mA ±250 µA ±25 µA	0.38 mV	±(0.05% of value + 12.5 mV)
2.1.1.4		0 V to +6.0 V	±1200 mA	0.38 mV	±(0.05% of value + 12.5 mV)
2.1.1.5	Negative	-20.0 V to 0 V	±500 mA ±25 mA ±2.5 mA ±250 µA ±25 µA	0.38 mV	±(0.05% of value + 12.5 mV)
2.1.1.6		-6.0 V to 0 V	±1200 mA	0.38 mV	±(0.05% of value + 12.5 mV)

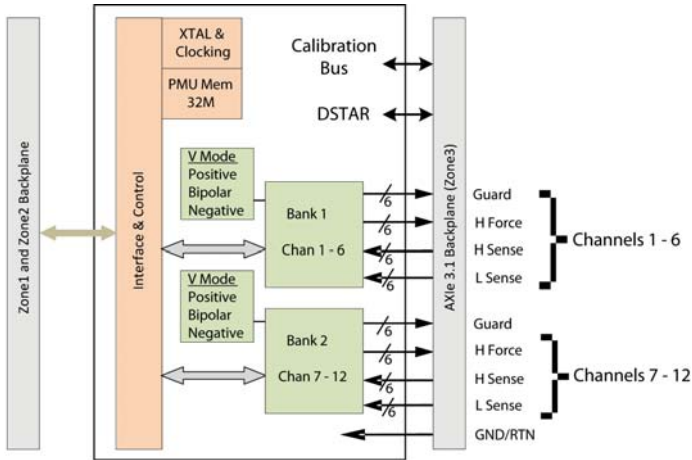

Figure 1-1: Top Level DPS12 Block Diagram

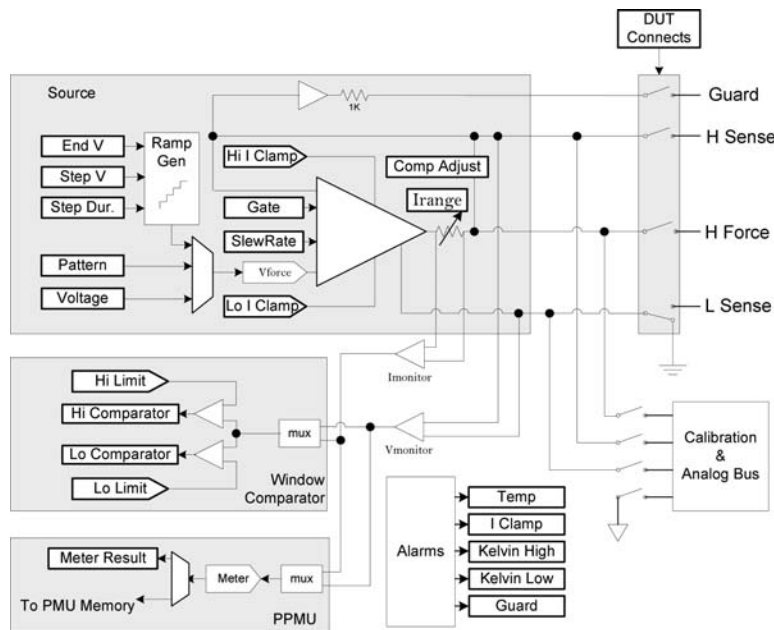

Figure 1-2: Channel Block Diagram

2.2 Measure Current Ranges

	Current Range*	Resolution	Accuracy
2.2.1.1	±1200 mA	36.6 μ A	±(0.25% of value + 2.4 mA)
2.2.1.2	±500 mA	15.3 μ A	±(0.25% of value + 1.0 mA)
2.2.1.3	±25 mA	0.76 μ A	±(0.1% of value + 50 μ A)
2.2.1.4	±2.5 mA	76 nA	±(0.1% of value + 5.0 μ A)
2.2.1.5	±250 μ A	7.6 nA	±(0.1% of value + 500 nA)
2.2.1.6	±25 μ A	0.76 nA	±(0.1% of value + 50 nA)

2.3 Measure Voltage Ranges

	Voltage Range	Current Range*	Resolution	Accuracy	
2.3.1.1	Bipolar (default)	-12.0 V to +12.0 V	±500 mA ±25 mA ±2.5 mA ±250 μ A ±25 μ A	0.38 mV	±(0.05% of value + 12.5 mV)
2.3.1.2		-6.0 V to +6.0 V	±1200 mA	0.38 mV	±(0.05% of value + 12.5 mV)
2.3.1.3	Positive	0 V to 22.0 V	±500 mA ±25 mA ±2.5 mA ±250 μ A ±25 μ A	0.38 mV	±(0.05% of value + 12.5 mV)
2.3.1.4		0 V to +6.0 V	±1200 mA	0.38 mV	±(0.05% of value + 12.5 mV)
2.3.1.5	Negative	-20.0 V to 0 V	±500 mA ±25 mA ±2.5 mA ±250 μ A ±25 μ A	0.38 mV	±(0.05% of value + 12.5 mV)
2.3.1.6		-6.0 V to 0 V	±1200 mA	0.38 mV	±(0.05% of value + 12.5 mV)

2.4 Current Clamps

	Current Range*	Resolution	Accuracy
2.4.1.1	±1200 mA	36.6 μ A	±60 mA
2.4.1.2	±500 mA	15.3 μ A	±25 mA
2.4.1.3	±25 mA	0.76 μ A	±1.25 mA
2.4.1.4	±2.5 mA	76 nA	±125 μ A
2.4.1.5	±250 μ A	7.6 nA	±12.5 μ A
2.4.1.6	±25 μ A	0.76 nA	±1.25 μ A

2.5 Short-Circuit Protection (Outputs connected to ground, Bi-Polar Mode)

	Current Range*	Max Pulse (Continuous on)	Max Duty Cycle
2.5.1.1	±1200 mA ±500 mA ±25 mA ±2.5 mA ±250 μ A ±25 μ A	600 s	100%

2.6 Force Voltage Settling Time

Note:

1. To within 10 mV of programmed value
2. Using compensation for 229 nF to 380 nF capacitance
3. Clamps disabled

	Current Range*	Settling Time (Typ.)	Conditions
2.6.1.1	±1200 mA	16 μs	3.7 V step, RDUT=2.4Ω, CDUT=0.22 μF, full dc load
2.6.1.2	±500 mA	34 μs	15 V step, RDUT=30Ω, CDUT=0.22 μF, full dc load
2.6.1.3	±25 mA	125 μs	20 V step, RDUT=800Ω, CDUT=0.22 μF, full dc load
2.6.1.4	±2.5 mA	300 μs	10 V step, RDUT=4 kΩ, CDUT=0.22 μF, full dc load
2.6.1.5	±250 μA	300 μs	10 V step, RDUT=40 kΩ, CDUT=0.22 μF, full dc load
2.6.1.6	±25 μA	400 μs	10 V step, RDUT=400 kΩ, CDUT=0.22 μF, full dc load

2.7 Adjacent Channel Ganging

An odd channel may be ganged together with the next consecutive even channel within its bank (i.e. Channels 1 and 2, 3 and 4, etc...) to produce higher currents. The master and slave channels will share the current load equally. Available current ranges for ganging are 25 mA, 500 mA and 1200 mA.

Channel	Configuration
1 and 2	Master and slave, respectively
3 and 4	Master and slave, respectively
5 and 6	Master and slave, respectively
7 and 8	Master and slave, respectively
9 and 10	Master and slave, respectively
11 and 12	Master and slave, respectively

2.8 Window Comparator

Each channel has a window comparator which can compare the supply's voltage or current against a pair of limits. High and low thresholds are programmable for either voltage or current. The window comparators can also be used as a trigger source for synchronization.

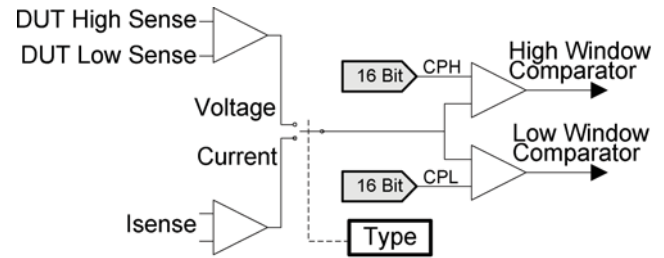

Figure 2-1: Window Comparator

	Mode	Resolution	Accuracy (Typ.)
1.1.1.1	Voltage	0.38 mV	±12 mV
1.1.1.2	Current (±1200 mA)	36.6 μA	±18 mA
1.1.1.3	Current (±500 mA)	15.3 μA	±7.5 mA
1.1.1.4	Current (±25 mA)	0.76 μA	±375 μA
1.1.1.5	Current (±2.5 mA)	76 nA	±37.5 μA
1.1.1.6	Current (±250 μA)	7.6 nA	±3.75 μA
1.1.1.7	Current (±25 μA)	0.76 nA	±375 nA

2.9 Voltage Ramp Function

Each DPS12 channel has the ability to apply a falling or rising voltage ramp to the DUT. The rate of this ramp is programmable and the ramping function itself will be interrupted or prevented from starting if any of the following alarms are detected:

- Kelvin high
- Kelvin low
- Guard short
- Die temperature
- Current limit

	Description	Value
1.1.1.1	Sample period (min.)	1.2 μS
1.1.1.2	Sample period (max.)	306 μS
1.1.1.3	Sample period resolution	1.2 μS
1.1.1.4	Voltage step resolution	6.1 mV/12 Bits
1.1.1.5	Trigger	Via software

2.10 Digitizing PMU Measurements

All channels support data storage utilizing a shared 32 M sample memory to store voltage or current measurements at rates up to 200 Ksps. Each of the available channels can be configured as follows:

1. The sample period and number of samples is programmable and may be triggered from the any of four AXIe 3.1 compliant DSTAR trigger lines.
2. Any one of the four DSTAR trigger lines may be used as a sample clock for measurement data storage.

	Description	Value
1.1.1.1	Sample period (min.)	5 uS
1.1.1.2	Sample period (max.)	256 uS
1.1.1.3	Sample period resolution	1 uS

2.11 Alarms

Comparators exist within each channel to monitor the following alarms.

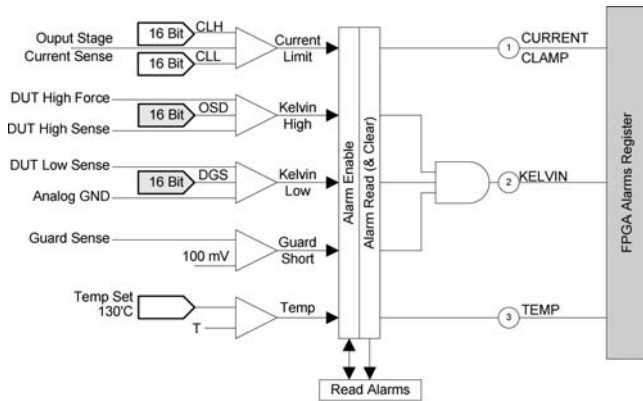

Figure 2-2

Alarm	Threshold
Kelvin High	$(V_{HighForce} - V_{highSense}) > \text{Programmed threshold}$
Kelvin Low	$(\text{Analog GND} - V_{LowSense}) > \text{Programmed threshold}$
Guard Short	
Die Temperature	130°C
Current Limit	High or Low current clamp is active

2.12 DSTAR Triggers

Each channel can source or receive any one of four DSTAR trigger lines. DSTARs may be used to trigger PMU digitization or used as a sample clock for digitizing PMU measurements. See Section 2.10, for digitization PMU measurements.

Any channel from the DPS12 instrument may drive any one of the four DSTAR trigger lines to synchronize other instruments in the system. The source of the DSTAR triggers are:

- Digitizer measurement complete
- Low window comparator
- High window Comparator

Triggers sourced to the DSTAR lines may in be in one of two forms:

- 1) Edge mode: A 20 ns positive-going pulse is generated for each edge detected from the trigger source. The pulse is synchronized to the backplane 100 MHz clock.
- 2) Level mode: The trigger signal goes high when the selected level is present and goes low when the selected level is not present. The conditioned trigger signal is synchronized to the backplane 100 MHz clock and driven to the selected DSTAR line.

2.13 Force Pattern Generator

A single force pattern generator can output voltage patterns to any combination of the twelve channels. The user programs the voltage to force and the delay time for each set voltage (dwell) and may be triggered from any of the four AXIe 3.1 compliant DSTAR trigger lines. Memory depth is 32 MB.

3 Board and Bank Current Limitations

3.1 Bank Current Limitations

Power on the DPS12 is divided into two banks of six channels. Numbers are representative for both individual channel assignments as well as ganged channels. Any individual channel may be set to its maximum current rating provided the current rating for the entire bank is not exceeded. Power is delivered assuming outputs are tied to ground. (See also short-circuit protection section 2.5.) Each channel is protected by its own thermal shutdown circuit. The Figures below illustrate the voltage/current capability for each of the two modes of operation: Bipolar and positive modes.

The table below illustrates the maximum allowable current per bank and per DPS12 instrument.

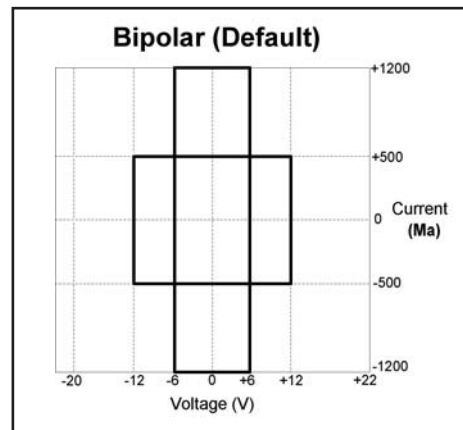

Figure 3-1: Bipolar Mode Current

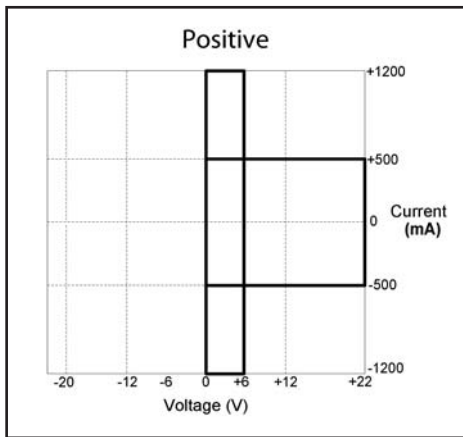

Figure 3-2: Positive Mode Current

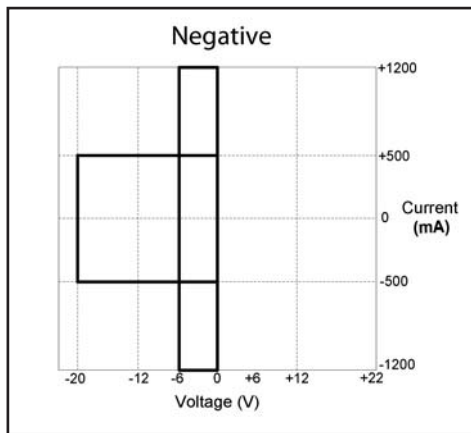

Figure 3-3: Negative Mode Current

	Current Range	Max Current	Max Current
3.1.1.1	±1200 mA	7.2 A	12 A
3.1.1.2	±500 mA ±25 mA ±2.5 mA ±250 µA ±25 µA	2.4 A	

Table 3-1: Maximum Current per Bank and per DPS12 Instrument

For the very latest specifications visit www.aeroflex.com

CHINA Beijing

Tel: [+86] (10) 6539 1166
Fax: [+86] (10) 6539 1778

CHINA Shanghai

Tel: [+86] (21) 5109 5128
Fax: [+86] (21) 5150 6112

CHINA Shenzhen

Tel: [+86] (755) 3301 9358
Fax: [+86] (755) 3301 9356

FINLAND

Tel: [+358] (9) 2709 5541
Fax: [+358] (9) 804 2441

FRANCE

Tel: [+33] 1 60 79 96 00
Fax: [+33] 1 60 77 69 22

GERMANY

Tel: [+49] 89 99641 0
Fax: [+49] 89 99641 160

HONG KONG

Tel: [+852] 2832 7988
Fax: [+852] 2834 5364

INDIA

Tel: [+91] 80 [4] 115 4501
Fax: [+91] 80 [4] 115 4502

JAPAN

Tel: [+81] (3) 3500 5591
Fax: [+81] (3) 3500 5592

KOREA

Tel: [+82] (2) 3424 2719
Fax: [+82] (2) 3424 8620

SCANDINAVIA

Tel: [+45] 9614 0045
Fax: [+45] 9614 0047

SINGAPORE

Tel: [+65] 6873 0991
Fax: [+65] 6873 0992

UK Stevenage

Tel: [+44] (0) 1438 742200
Fax: [+44] (0) 1438 727601
Freephone: 0800 282388

USA

Tel: [+1] (316) 522 4981
Fax: [+1] (316) 522 1360
Toll Free: 800 835 2352

As we are always seeking to improve our products, the information in this document gives only a general indication of the product capacity, performance and suitability, none of which shall form part of any contract. We reserve the right to make design changes without notice. All trademarks are acknowledged. Parent company Aeroflex, Inc. ©Aeroflex 2003.

www.aeroflex.com
info-test@eroflex.com



Our passion for performance is defined by three attributes represented by these three icons: solution-minded, performance-driven and customer-focused.

Part No. 46891/460, Issue 1, 08/11