

# ATE

## 4200 Series CODA - Capacitor Orientation Defect Analysis

**AEROFLEX**  
A passion for performance.

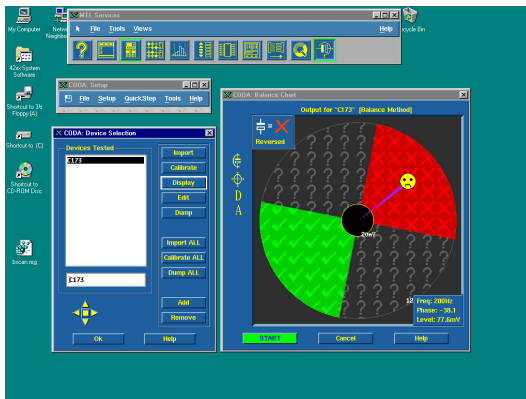

Enables the detection of reversed electrolytic capacitors to increase the fault coverage capability of the test system

- Supports axial, radial and surface mount packages
- Stable and repeatable measurements
- Three measurement modes
- Detects reversed capacitors within a parallel set
- Graphical user interface for rapid debug
- Extends existing capacitor test capability
- Patent applied for

### Introduction

*Conventional In-Circuit test systems are limited when it comes to testing electrolytic capacitors. Whilst they are proficient at measuring the value of the capacitor, they are unable to determine it's orientation. A reversed component will fail some time after the PCB is powered up, occasionally during the In-Circuit test, more often during a soak test, or worse of all, after delivery to the customer.*

*Although competitive methods have claimed the ability to test reversed capacitors, the Aeroflex CODA technique offers a first with truly reliable and repeatable measurements. Both single components and those found within parallel sets can be tested and diagnosed down to the failing capacitor.*

*The Aeroflex CODA technique enables the 4200 series to detect reversed capacitors at the In-*

*Circuit test stage where rework costs are comparatively low. Consequently, by preventing the fault progressing to later stages of the production chain, the system contributes to a reduction in manufacturing costs.*

### Mechanical Aspects

The hardware required by the CODA technique falls into three sections. The detection point at the end of the probe is a suitably sized plate. The probe itself is clamped above the unit under test and connected to a CMUX signal processing board. The CMUX card is mounted in the fixture and supports up to 32 probes.

### Three Test Methods

There are three measurement modes to allow the test engineer a high degree of flexibility across a range of component configurations. Common to each mode is the application of an AC stimulus across the capacitor under test with phase and magnitude measurements being taken via the probe. The three modes, balance, compare and ratio, differ in the number and interpretation of the measurements taken. Appropriate test mode selection is made using the Graphical User Interface.

### Test Calibration

Each of the three test modes require the measurement to be compared against that of a known good component. This process involves the selection of a suitable stimulus frequency and the recording of the actual measurement under those conditions. There are three methods of selecting a suitable frequency, fixed, sweep and auto, again selected using the Graphical User Interface.

### Graphical User Interface

The Computer Aided Program Generation software CAPG is used to generate 4200 series test programs. Reversed capacitor detection is treated in the same way as all other test methods in that it can be

For the very latest specifications visit [www.aeroflex.com](http://www.aeroflex.com)

selected for appropriate components via the user interface. The relevant code is included in the test program which is then run through the debug process.

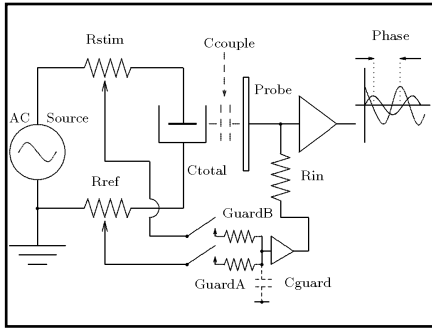

The CODA set up icon is contained in the top-level services panel. Whilst there a number of set up menus available, most test engineers will use the QuickStep option which is designed as a guide through all of the relevant processes.

The CODA Balance Chart screen shot shows the primary debug tool, indicating both phase and magnitude measurements. The various segments within the display indicate correct, reversed or unknown results.

The use of a Graphical User Interface allows the test engineer to quickly implement the method without extending the test programming time. In addition, these intuitive tools ensure that the technique is easy to learn, both for those familiar with the 4200 series and also those new to the system.

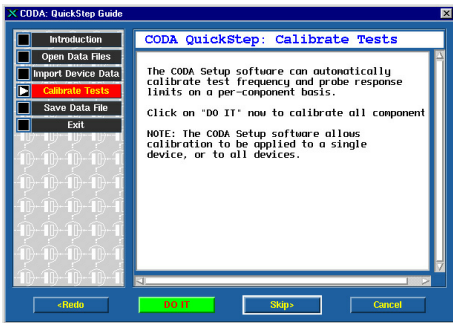

## SPECIFICATION

### Test Platforms

4220 and 4215

4200, 4205 and 4210 systems upgraded to PC control

### Input impedance

3.33 M $\Omega$

### Frequency response

20Hz to 10kHz

### Select inputs

HC logic levels

Protected by 10 k $\Omega$  resistor

### Supply voltage

22 to 25 V DC, <100 mA

**CHINA**  
Tel: [+86] (10) 6467 2716  
Fax: [+86] (10) 6467 2821

**EUROPE**  
Tel: [+44] (0) 1438 742200  
Fax: [+44] (0) 1438 727601

**FRANCE**  
Tel: [+33] 1 60 79 96 00  
Fax: [+33] 1 60 77 69 22

**HONG KONG**  
Tel: [+852] 2832 7988  
Fax: [+852] 2834 5364

**SCANDINAVIA**  
Tel: [+45] 9614 0045  
Fax: [+45] 9614 0047

**SPAIN**  
Tel: [+34] (91) 640 11 34  
Fax: [+34] (91) 640 06 40

**UNITED KINGDOM**  
Tel: [+44] (0) 1438 742200  
Toll Free: [+44] (0800) 282 388 (UK only)  
Fax: [+44] (0) 1438 727601

**USA**  
Tel: [+1] (316) 522 4981  
Toll Free: [+1] (800) 835 2352 (US only)  
Fax: [+1] (316) 522 1360



As we are always seeking to improve our products, the information in this document gives only a general indication of the product capacity, performance and suitability, none of which shall form part of any contract. We reserve the right to make design changes without notice. All trademarks are acknowledged. Parent company Aeroflex, Inc. ©Aeroflex 2004.

[www.aeroflex.com](http://www.aeroflex.com)  
[info-test@eroflex.com](mailto:info-test@eroflex.com)