

Application Note



Measurement of Frequency Stability and Phase Noise



The stability of an RF source is often a critical parameter for many applications. Performance varies considerably with different types of sources and consequently there are a number of different methods of measuring stability or phase noise.

Introduction

An ideal frequency source generates only one output signal with no uncertainty in its output frequency. In reality, however, all signal sources exhibit some uncertainty in

their instantaneous output frequency. The uncertainty can be expressed in a number of different ways. The method of expressing the uncertainty is likely to depend upon the intended application as well as the performance of the

signal source, and in many cases a source may be characterised in more than one way.

Very stable frequency sources such as crystal oscillators and Rubidium or Caesium frequency standards are principally measured in terms of their long and short term frequency stability by directly measuring the source with a frequency counter. Ageing rate is used to express the long term change of the frequency over a period of many hours (or more) of the source while the short term stability is a measure of the random fluctuation of the source over a period of the order of seconds. Provided a frequency counter with enough frequency resolution and a frequency standard with adequate performance is used as a reference the measurement of stability presents no serious problems.

More typical sources tend to have their frequency stability measured in other ways. For communications systems the most common method of expressing the frequency uncertainty is either as residual phase or frequency modulation or as phase noise. Residual modulation is typically measured by demodulating the carrier, filtering the base band signal through a band pass filter and measuring the signal in terms of peak, average or RMS deviation in Hz or Radians.

Phase noise is the most common method of expressing frequency instability. The carrier frequency instability is expressed by noting the average carrier frequency and then measuring the amount of power at various offsets from the carrier frequency in a defined bandwidth as a logarithmic ratio compared to the total carrier power. The power ratio is usually normalised to be the equivalent signal power that would be present if the measurement bandwidth was 1 Hz. For communication systems the most important offset frequencies are those around 1 kHz since this strongly influences the residual FM (and therefore the ultimate signal to noise ratio) and at offsets between 10 kHz and 25 kHz since it effects the ability to measure adjacent channel selectivity on a narrow band receiver.

The various ways of expressing frequency stability are all measurements of the same physical characteristics but are weighted in terms of the critical characteristics of their application. The most useful general measurement, however, is the phase noise characteristics since from a phase noise plot the other measurements can be derived. In practice it is unlikely that a phase noise measurement will be carried out over a long enough time to derive the long term stability of a frequency standard, but most modern RF and microwave sources are synthesized from a crystal frequency reference and so their long term characteristics are relatively well behaved and are dominated by the crystal oscillator.

Measuring Phase Noise

The actual performance of frequency sources varies considerably and consequently making measurements can be complex. Different methods can be used according to the expected performance and the controls available to set up a measurement.

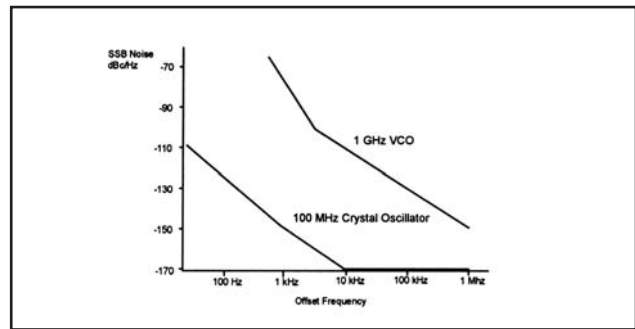

Figure 1 - Typical Oscillator Noise Performance

Crystal oscillators can exhibit a phase noise of -170 dBc/Hz at a 20 kHz offset from a carrier of 100 MHz. A well designed voltage controlled oscillator covering a frequency range of a quarter of an octave at 1 GHz will produce phase noise of -115 dBc/Hz at a 20 kHz offset frequency. A typical microwave YIG oscillator could give significantly worse performance and have the added complication of including large amounts of low frequency uncertainty from disturbance of the tuning field from AC power supply circuits. Measuring such widely divergent oscillators causes considerable difficulties and it is not surprising that no one technique can solve all the problems.

Four basic measurement techniques are described based on Spectrum Analyzers, Delay Line Discriminators, Quadrature Technique and FM Discriminators.

Spectrum Analyzers

Since Spectrum Analyzers measure the RF signal power in a specific bandwidth they can clearly be used to measure phase noise. Most modern analyzers include software functions which will convert a measured signal level from its absolute value to the equivalent noise signal in a 1 Hz bandwidth. By measuring the total carrier power (on a wide filter setting) and then measuring the noise signal normalised to a 1 Hz bandwidth a phase noise measurement can be derived.

The availability of software correction to normalise the bandwidth of the measurement to 1 Hz can save considerable effort since the measurement bandwidth of a spectrum analyzer is unlikely to be equal to the resolution bandwidth. The bandwidth of the spectrum analyzer is never the "brick wall" filter that notionally needs to be used for noise measurements so the software corrects the measurement to allow for the equivalent noise bandwidth of the analyzers filter. The correction between resolution bandwidth and noise bandwidth is dependent upon the form factor of the filter and therefore could depend on which filter has been selected (not all filters in a spectrum analyzer have the same form factor).

When displaying phase noise spectrum analyzers are typically using logarithmic detectors rather than true RMS detectors and therefore respond differently to noise than they do to coherent (sine wave) signals. The software correction factors allow for this effect by assuming that the signal power distribution for noise is Gaussian - which is generally the case if there are no sources of impulsive noise.

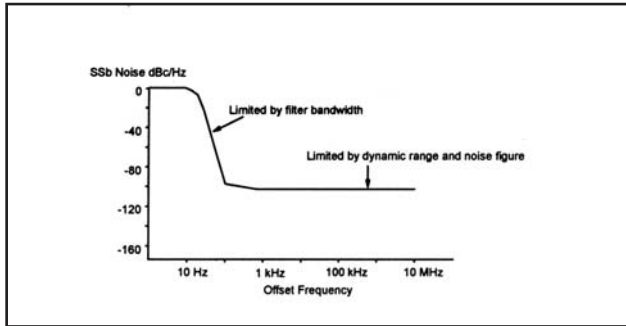

Figure 2 - Spectrum Analyzer Noise Limitations

In practice the performance of simple spectrum analyzers measurements is very limited. A typical spectrum analyzer is not adequate to measure noise at offset frequencies much beyond 1 kHz and the minimum filter resolution bandwidth of 3 Hz or 10 Hz limits measurements to offsets frequencies above 50 Hz.

The performance at larger offsets is limited by the performance of the synthesizers used to frequency convert the input signal to the measurement frequency and the relatively poor noise figure of a spectrum analyzers front end converter (which usually is optimised to obtain the best linear operating range).

Use of Preselection Filters on Spectrum Analyzers

For some applications the deficiencies of spectrum analyzers can be partially overcome by the use of band pass filter. A typical measurement will require the use of second reference RF or microwave source and a mixer to convert the signal to an intermediate frequency (IF). The signal from the mixer is then passed through a bandpass filter and amplifier before being measured by the spectrum analyzer. Typically the bandpass filter is a commercially available inductor/capacitor, crystal or ceramic IF filter commonly used in radio receivers.

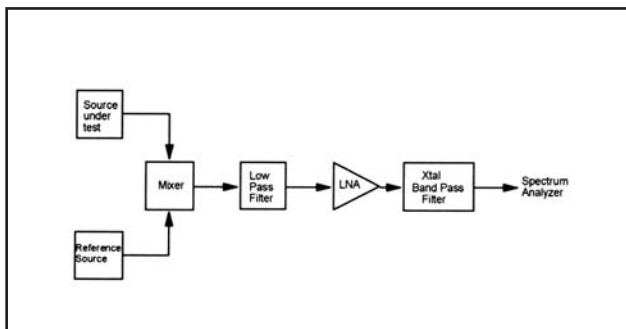

Figure 3 - Using a Spectrum Analyzer with a Preselection Filter

The RF signal level is first measured by setting the IF signal to be in the pass band of the filter and measuring it with the spectrum analyzer. The frequency of the reference source is then offset by the required offset frequency of the measurement and the spectrum analyzer is used to measure the noise level. The bandpass filter rejects the main carrier component from the mixer and therefore prevents the spectrum analyzers synthesizer noise from mixing with the carrier component and producing noise which would mask the signal being measured.

Some care needs to be taken in making measurements in this

way. Suitable filters with narrow bandwidths are rarely designed for 50 ohm operation and often have severe changes of impedance with frequency. The mixer has to be buffered from this impedance variation to avoid errors due to reflected signals remixing. The filters can also exhibit non linear behaviour at both low levels (particularly crystals) and high levels (as crystals or ceramics exceed their power handling levels). These problems combined with frequency response unflatness in the pass band and compression in the recovery amplifier can make the measurement uncertainty high unless care is taken.

The technique is also restricted to measurements at offsets of typically greater than 10 kHz since it relies on the filter having to reject a significant proportion of the IF carrier signal.

Delay Line Discriminator

A broad band FM discriminator can be constructed by taking the RF signal to be measured and splitting it into two paths. One path is fed directly into a mixer and the second path is passed through a delay line and the output is mixed with the non-delayed signal. The delay line includes an electronically variable phase shifter or a mechanically adjustable transmission line so that the phase of the two signals applied to the mixer can be set for phase quadrature.

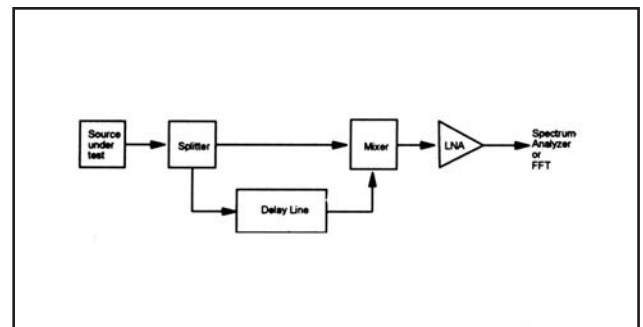

Figure 4 - Delay Line Discriminator

The measurement system behaves as a conventional FM discriminator if the inputs to the mixer are set to be in phase quadrature. This can be intuitively understood by considering the following:

- The mixer output voltage is a measurement of the phase difference between the two signals.
- The phase difference is obtained from a time delay between the two signals.
- A difference in time at high offset frequencies represents a larger phase shift than a difference in time at low offset frequencies and that the slope of the rate of change is 6 dB per octave.
- The above is exactly the characteristics expected if the demodulation process is equivalent to an FM discriminator.

The bandwidth of the discriminator is a classic Sine x/x response with the first null at a frequency equivalent to the time delay between the two RF paths. The conversion sensitivity of the discriminator is dependent upon the RF level applied, the conversion loss of the mixer and the time delay of the delay line. The longer

the delay line the greater the sensitivity of the measurement but the more restricted its measurement bandwidth due to the Sine x/x response.

The great advantage of this technique is that it does not require the use of a second RF source to convert the frequency of the source to be measured to an IF or base band signal. This removes one potential source of error i.e. an additional source of noise. Also, since the method is based on the use of a frequency discriminator it is not very prone to being overloaded by low frequency sources of phase noise (e.g. power supply related signals). Some drift of the carrier frequency during measurement can also be tolerated since it simply slightly changes the DC signal level from the mixer without greatly affecting the calibration.

It does have the practical disadvantage of not being easily automated, microwave mixers with DC coupled outputs can be difficult to obtain and the measurement system needs to be calibrated which can be troublesome.

The sensitivity of the system is dependent upon the applied RF signal levels. The normal method of calibration is to adjust the time delay to find the peak positive and negative voltage that can be obtained from the mixer. From this the sensitivity can be deduced if it is assumed that the mixer is behaving in a linear fashion.

At microwave frequencies the insertion loss of the delay line can result in the sensitivity of the measurement being limited. In general this method is not capable of measuring high performance oscillators over a large bandwidth but is capable of measuring typical free running YIG and RFVCO sources.

Quadrature Technique

In the Quadrature System two oscillators at identical frequencies are used. Typically one of the oscillators will be the source being tested and the other will be a reference source whose performance is known to be better than the source under test. The oscillator outputs are combined in a mixer and the resulting output signal is filtered and amplified by a Low Noise Amplifier (LNA). The output from the mixer is typically measured by a Fast Fourier Transform (FFT) Analyzer or a Spectrum Analyzer.

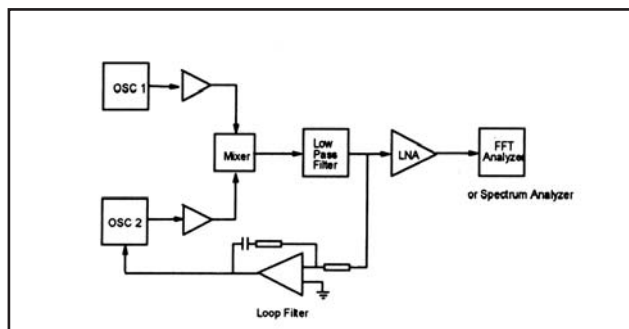

Figure 5 - Quadrature Technique

In order to provide a valid measurement the phase of the two oscillators has to be set so that they are in phase quadrature at the mixer input. The mixer output will then be close to 0 volts and the mixer will behave as phase detector.

Setting the sources to be in phase quadrature is not always very

easy. If both frequency sources are synthesizers with good long term stability then there is usually not a great problem. However in the more typical applications where measurements are undertaken under less than ideal conditions a feedback system has to be used to maintain phase quadrature. The feedback system forms a phase locked loop which adjusts one of the oscillators to correct for departures from phase quadrature.

The use of a phase locked loop to maintain phase quadrature does imply some knowledge of the tuning characteristics of one of the oscillators and the mixer drive levels since the bandwidth of the phase locked loop is effected by both of these parameters. In practice for many sources the availability of a low noise signal generator with a high performance DC coupled FM capability, such as the 2040 Series, can considerably simplify the measurement system.

When measuring VCO's or YIG oscillators the relatively high levels of low frequency noise can also cause problems since they can overload the mixer or the low noise amplifiers after the mixer. If the peak phase excursion of the noise exceeds 0.2 radians the mixers phase detector response becomes non-linear and invalidates the measurement. Under these conditions the phase locked loop bandwidth has to be widened in order to restrict the peak phase excursion.

In order to carry out a measurement the quadrature system has to be calibrated since the sensitivity of the measurement is dependent on the insertion loss and drive level used for the mixer.

If the LO input level required for the mixer is substantially greater than the RF port drive a calibration assessment can be obtained by offsetting the frequency of one of the sources by a small amount. A low frequency sine wave is produced at the output of the mixer whose amplitude can be measured to determine the sensitivity of the mixer.

If both ports of the mixer are driven at a high level to give the maximum sensitivity then the waveform from the mixer will be more like a triangle waveform and the mixer sensitivity should be more linear with errors in phase quadrature present. However, the slope of the triangle wave is more difficult to measure accurately than in the case where a sine wave is produced.

A further complication in the calibration process can arise if the drive signals are not well matched to the source impedances. Whichever port of the mixer is driven hard the mixer tends to convert that signal to a square wave and reflections can cause re-mixing and slope perturbations in the output.

An alternative, and often more reliable, method of calibration is to use a signal generator as one of the sources and to set a known amount of phase or frequency modulation. Measuring the resulting output can provide the required calibration information. The phase modulation applied has to have a modulation index of less than 0.1 radians to avoid mixer overload, and a modulation frequency significantly in excess of the phase locked loop bandwidth used for setting up phase quadrature.

Another source of error in the measurement is the phase locked loop used to set up phase quadrature. The loop tends to remove low frequency phase noise that is present on the source under test.

The errors introduced by the phase locked loop must either be set so that they are below the frequency offset of interest or they have to be corrected for by measuring the loop characteristics and then mathematically correcting the measurement result.

Injection Locking

There is a further practical problem which needs to be assessed. If there is a lack of isolation between the two RF sources then as their frequencies are brought close together there will be a tendency for them to become injection locked. If one of the oscillators is a VCO then this is certain to happen and will need to be characterised. Under these conditions it is advisable to ensure that the deliberate phase locked loop bandwidth exceeds the injection locked bandwidth. Even then the loop must be characterised if accurate measurements are to be made on the source.

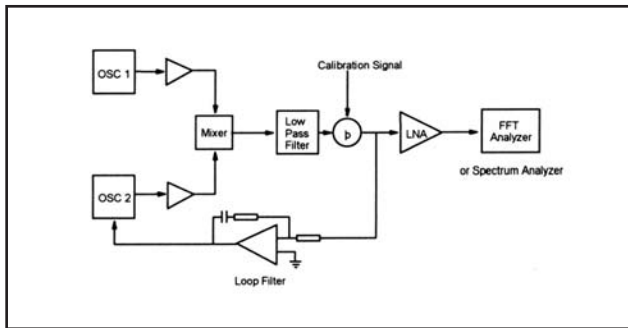

Figure 6 - Measuring the Phase locked Loop effects.

The phase locked loop response can be measured by injecting a calibration signal into the loop. The calibration signal can be a swept signal (e.g. the modulation oscillator of a signal generator such as 2040 series) or a noise source (often available on an FFT analyzer). Outside the loop bandwidth the analyzer measures the amplitude of the calibration signal but inside the loop bandwidth the PLL attenuates the calibration signal. From the frequency response plotted on the analyzer a correction plot can be deduced and applied to correct the phase noise measurement results.

Care needs to be taken when interpreting results which include high correction factors since other factors, including injection locking, may start to effect the measurement repeatability.

If a synthesized source is measured by operating the source of a common frequency standard with the reference source it should be remembered that under these conditions a phase locked loop is still present which locks the source phases together - but the phase locked loop is inside the source rather than being external. Consequently the noise being measured is the added noise and takes no account of the noise performance of the frequency reference.

FM Discriminator Method

This method uses a mixer and a reference source to convert the signal to an IF where it is demodulated by an FM discriminator. In principle any FM discriminator can be used but its noise performance is likely to have a critical effect on the ability to make a phase noise measurement. A method used at Aeroflex for measuring high performance signal generators uses a high performance 1.5

MHz discriminator.

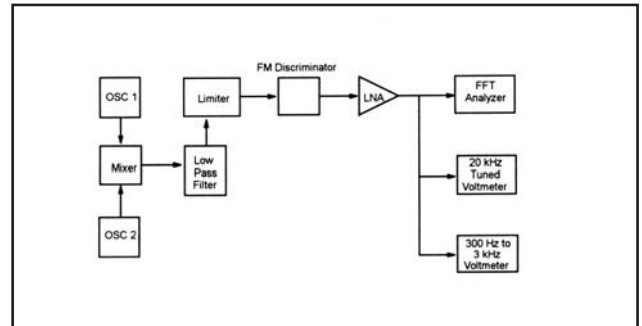

Figure 7 - FM Discriminator Method

The discriminator is based on the use of a splitter, a band pass filter and a mixer acting as a phase detector. The band pass filter uses a coupled resonator design that ensures that at the centre frequency of operation the phase shift through the filter is 90° so the inputs to the phase detector are in quadrature. In its practical implementation two band pass filters are available, one allowing a measurement bandwidth of up to 20 kHz and the other allowing measurements to 100 kHz offset.

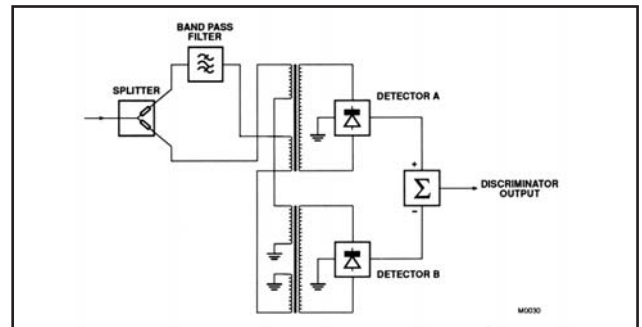

Figure 8 - A High Performance FM Discriminator

The band pass filter phase and amplitude response determines the linearity of the discriminator. As the frequency of the IF deviates from its nominal value the phase shift through the band pass filter changes and alters the signal that appears at the output of the discriminator. The amplitude response of the filter also effects the output from the phase detector and by careful design the two effects can be combined to produce a discriminator with a substantially linear frequency versus output voltage characteristic.

This linear characteristic enable noise measurements to be undertaken on free running RF sources and allows measurements to be undertaken on sources which have sources of relatively high modulation index present.

In principle the system behaves in a similar way to the delay line discriminator method but it does have some substantial advantages. In particular since the discriminator operates at an IF frequency a limiter can be used to control the amplitude of the signal into the discriminator. Operation at an IF also allows the FM discriminator to be implemented using a different type of phase detector operating at much higher signal levels. The design used in the IFR version uses two transformer coupled full wave rectifiers operating at a high signal level.

As with the Delay Line Discriminator it is important to remember that what is being measured is FM noise rather than phase noise. Conversion between the two measurements is relatively straight forward and some FFT analyzers are available which can mathematically convert the measurement result automatically.

Calibration of the system is very straight forward since the system sensitivity is independent of the input drive level to the frequency conversion mixer. Once a system has been constructed the calibration factors are constants which can be allowed for by periodic (6 monthly) calibration checks. Calibration is typically performed by making one of the sources a signal generator with calibrated FM or phase modulation.

The system in use at Aeroflex also includes a meter to measure the residual FM of a signal source in a 300 Hz to 3 kHz bandwidth (a common signal generator specification parameter) and a tuned voltmeter to measure phase noise at 20 kHz offset.

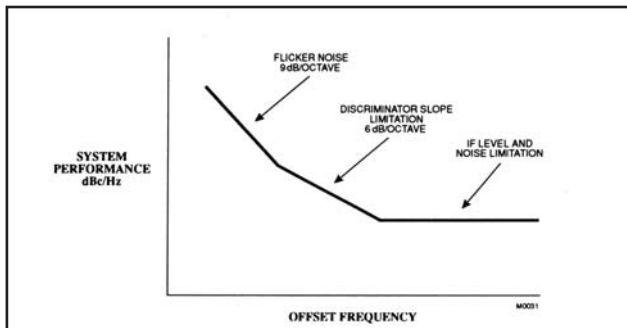

Figure 9 - Performance Limitations of the FM Discriminator Method

The performance of an FM discriminator system is limited by the noise figure of the amplifiers and limiters which recover the signal from the output of the mixer and by the performance of the discriminator itself. In the case of the system previously described the discriminator consists largely of passive components which exhibit a very good noise characteristics and consequently performance tends to be controlled by the slope of the discriminator and it is for this reason that two band pass filters are used to allow a compromise between sensitivity and measurement bandwidth.

The FM discriminator system does have some disadvantages. The need to have sources at different frequencies can be inconvenient. The mixing process can also generate intermodulation products which can give an false indication of there being spurious signals present. With a 1.5 MHz IF, however, this is unlikely to be a problem for carrier frequencies above 50 MHz. A less obvious problem is that if a source exhibits a flat noise profile from the offset frequency being measured to the image frequency (approximately 3 MHz offset for a 1.5 MHz IF) then the image frequency noise will be added to the noise at the required offset. Most signal sources, however, tend to exhibit better noise performance at the image frequency than at the closer offset frequencies. The substitution of an SSB mixer for the double balanced mixer can eliminate this problem.

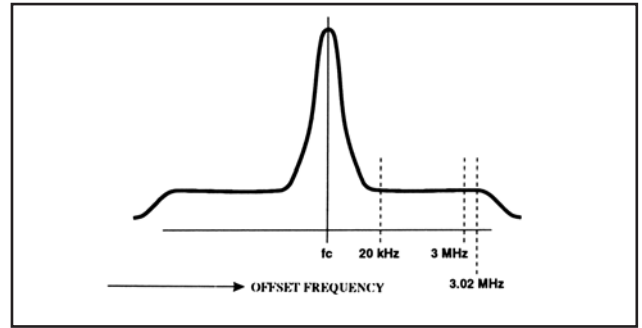

Figure 10 - Effect of noise at the image frequency

The performance of the FM Discriminator system used at Aeroflex is adequate to measure the best signal generators commercially available and is even capable of measuring good quality crystal oscillators. The availability of this measurement system was essential in order to develop the 2040 series low noise signal generators.

Typical System Performance -20kHz offset		
i.f. level	100 kHz discriminator	20 kHz discriminator
0 dBm	-166 dBc	-170 dBc
-10 dBm	-162 dBc	-163 dBc
-20 dBm	-153 dBc	-153 dBc
Residual F.M. 300 Hz - 3.4 kHz peak weighted		
i.f. level	100 kHz discriminator	20 kHz discriminator
0 dBm	016 Hz	005 Hz
-10 dBm	016 Hz	005 Hz
-20 dBm	017 Hz	007 Hz

Figure 11 - Performance of a 1.5 MHz Discriminator system

Future Methods of Measurement

From the above discussion it can be seen that no one measurement scheme for phase noise can be said to offer a complete solution for all conditions. Of the methods discussed the most reliable technique is the FM Discriminator Method, since it is the most "fail safe" technique. Under ideal conditions the Quadrature technique can offer better capability but requires much more care (and time) to undertake a measurement. There are, however, other techniques which may be developed in the future which could offer other solutions. The most promising technique is the use of Analog to Digital conversion systems digitising IF signals from a conversion mixer.

Current performance is limited by A to D linearity and aperture dither but improvements in converters are being steadily made. The resulting noise and spurious tends to restrict the usefulness of this measurement technique to offset frequencies of a few kHz.

The use of band pass delta sigma converters or flash A to D converters may eventually make phase noise measurements considerably less stressful to the engineer than they are at present.

Spectrum Analyzers

Advantages

Simple use
Simple to calibrate

Disadvantages

Poor dynamic range
Cannot measure close to carrier noise
Difficult to measure sources with frequency drift

Delay Line Discriminator

Advantages

Requires no additional RF source
Can measure drifting RF sources

Disadvantages

Requires frequent calibration
Restricted dynamic range
Restricted bandwidth
Difficult to automate
Requires direct manipulation of microwave signals

Quadrature Technique

Advantages

Oscillators are the same frequency
Large dynamic range
Measurements at large and small offsets

Disadvantages

Requires calibration of every measurement
Requires use of PLL and prior knowledge of source
Takes along time to make accurate measurements
Easy to make errors

FM Discriminator

Advantages

Large dynamic range
Requires no frequent calibration
Very accurate and hard to make errors
Can measure drifting sources
Tolerates LF noise

Disadvantages

Requires a frequency offset source
Frequency offset range 10 Hz to 100 kHz
Frequency conversion can make results pessimistic

Figure 12 - Summary charts of the different methods

CHINA Beijing

Tel: [+86] (10) 6539 1166
Fax: [+86] (10) 6539 1778

CHINA Shanghai

Tel: [+86] (21) 5109 5128
Fax: [+86] (21) 5150 6112

FINLAND

Tel: [+358] (9) 2709 5541
Fax: [+358] (9) 804 2441

FRANCE

Tel: [+33] 1 60 79 96 00
Fax: [+33] 1 60 77 69 22

GERMANY

Tel: [+49] 8131 2926-0
Fax: [+49] 8131 2926-130

HONG KONG

Tel: [+852] 2832 7988
Fax: [+852] 2834 5364

INDIA

Tel: [+91] 80 5115 4501
Fax: [+91] 80 5115 4502

KOREA

Tel: [+82] (2) 3424 2719
Fax: [+82] (2) 3424 8620

SCANDINAVIA

Tel: [+45] 9614 0045
Fax: [+45] 9614 0047

SPAIN

Tel: [+34] (91) 640 11 34
Fax: [+34] (91) 640 06 40

UK Burnham

Tel: [+44] (0) 1628 604455
Fax: [+44] (0) 1628 662017

UK Cambridge

Tel: [+44] (0) 1763 262277
Fax: [+44] (0) 1763 285353

UK Stevenage

Tel: [+44] (0) 1438 742200
Fax: [+44] (0) 1438 727601
Freephone: 0800 282388

USA

Tel: [+1] (316) 522 4981
Fax: [+1] (316) 522 1360
Toll Free: 800 835 2352

As we are always seeking to improve our products, the information in this document gives only a general indication of the product capacity, performance and suitability, none of which shall form part of any contract. We reserve the right to make design changes without notice. All trademarks are acknowledged. Parent company Aeroflex, Inc. ©Aeroflex 2006.

www.aeroflex.com
info-test@eroflex.com



Our passion for performance is defined by three attributes represented by these three icons: solution-minded, performance-driven and customer-focused.

Part No. 46891/865, Issue 1, 02/07