

# Application Note

**AEROFLEX**  
A passion for performance.

## Diversity Receiver Testing with the 6413A



The Aeroflex 6413A is designed to test Duplex and Simplex Node B's as standard. With the addition of an external attenuator, it is possible to test the performance of a Node B's diversity receiver.

## Prerequisites

46891/958 - Aeroflex 6413A - Testing of UMTS Node B's. Describes how to set up and configure the 6413A to perform tests on a Node B in general.

## The Problem

Receiver diversity requires the use of two antennas for the receive signal. This presents the Node B with an increase in signal to noise ratio of about 3 dB due to correlation in signal power, but not in noise power. Therefore, assuming the received signal power on each antenna is the same, the apparent sensitivity would increase by about 3 dB.

Receive diversity operation is normally catered for by configuring one antenna port for the Transmit and Receive (Duplex) signals and the other for receive only.

The 6413A in its standard configuration is designed to perform BER measurements on a Node B with either a Duplex RF connection (antenna interface) or a Simplex (split RX and TX paths) antenna interface.

The 6413A is a high performance field tester. In order to minimize measurement uncertainty there are no switches in the RF path of the unit. As such, during "simplex" operation of the unit there is RF power transmitted simultaneously from the both the RF OUT (simplex) port and the main RF IN/OUT (Duplex) port.

To test the Node B's main receiver, the RF IN/OUT port of the 6413A is connected to the Node B's duplexer and the full suite of transmitter and receiver measurements can be carried out. Similarly, if there is no duplexer present the RF OUT can be connected to the receiver under test (i.e. either the main receiver or the diversity receiver) and the RF IN/OUT port to the transmitter. Again, a full suite of transmitter and receiver measurements can be made.

However, if the user wishes to test the diversity receiver and still make a connection to the transmitter via the duplexer, additional care needs to be taken to avoid erroneous results. The reason for this is that the RF IN/OUT port always has an output RF signal present so the following signal paths exist:

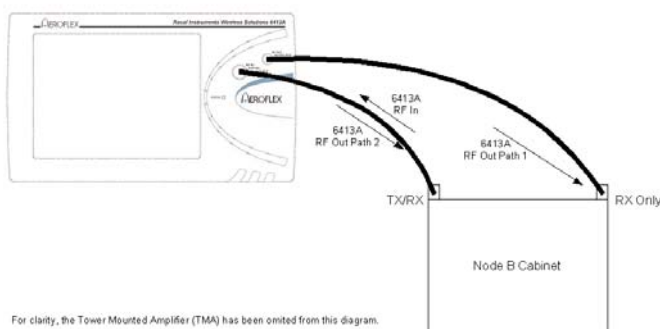

In the worst case, the two receivers sum the two input signals with no losses with the result that the Node B sees an apparent input power 3 dB higher than the level output by the 6413A. This in turn means that the measured absolute sensitivity level of the diversi-

ty receiver can be up to 3 dB lower than the actual performance.

What this test configuration will give is a measure of the Node B's absolute sensitivity with diversity enabled. However, for maintenance it is more useful to be able to measure the receivers independently so that any degradation in performance can be detected and appropriate action taken. Fortunately, inserting an external attenuator between the 6413A and the Node B's duplexer allows the diversity receiver's sensitivity to be correctly measured. A 20 dB attenuator will reduce the maximum potential error caused by the second signal path from 3 dB to 0.04 dB

The following sections explain the correct test configuration for making receiver measurements on Node Bs:

1. Receiver Sensitivity of duplex port only
2. Receiver Sensitivity of diversity port only
3. Receiver Sensitivity of Node B using full Receiver Diversity
4. Receiver Sensitivity of either receiver where no duplexer is present or is bypassed (simplex operation)

The first two configurations are the most appropriate for normal installation/commissioning and preventive maintenance of Node Bs on site.

## The Solutions

### 1. MEASURING RECEIVER SENSITIVITY OF THE DUPLEX PORT ONLY

In general, this test mode is the standard configuration for Receiver testing on any Node B configured in Duplex mode. The system setup would be similar to that shown below:

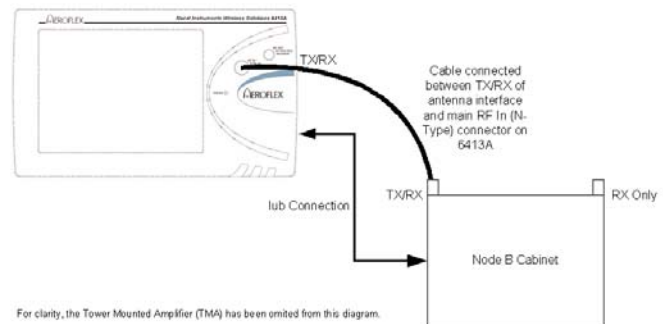

Figure 1: Shows RF and lub Connections. Duplex Port Sensitivity

## Test Method

The test method assumes that the user is able to generally configure the 6413A and the Node B to allow the 6413A to audit the Node B and enter "Link Established" mode.

1. Configure the 6413A to test in "Duplex" mode via the main menu à options screen.
2. Connect the 6413A main N-Type RF In/Duplex port to the TX/RX (Duplex) port of the antenna interface of the Node B (which may be direct on the cabinet, or on a Tower Mounted Amplifier (TMA)).

- Do not connect the 6413A RF Out port to the Node B's RX Only port. Leave this disconnected.
- Assuming the Node B has already been "Audited" the user will now be able to perform a Receiver Test such as Reference Sensitivity or Absolute Reference Sensitivity from the Receiver Tests menu.

## 2. MEASURING RECEIVER SENSITIVITY OF THE DIVERSITY PORT ONLY

The test mode below is used to test the Reference Sensitivity of the Diversity Port only and along with the first test (above) are the most common and useful tests to perform.

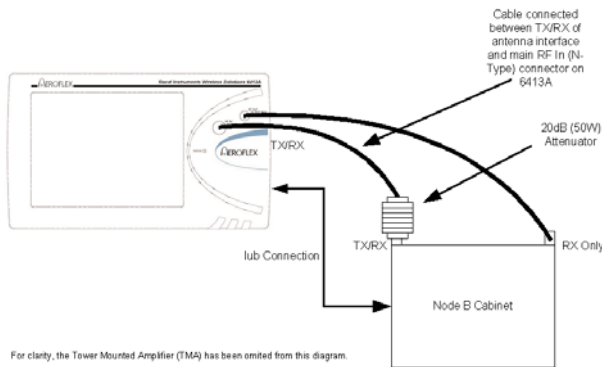

Figure 2: Shows RF and Iub Connections. Diversity Port Sensitivity

### Test Method

The test method assumes that the user is able to generally configure the 6413A and the Node B to allow the 6413A to audit the Node B and enter "Link Established" mode.

- Configure the 6413A to test in "Duplex" mode via the Main menu à options screen.
- Connect the 6413A main N-Type RF In/Duplex port to the 20 dB attenuator, and then the attenuator to the TX/RX (Duplex) port of the antenna interface of the Node B (which may be direct on the cabinet, or on a Tower Mounted Amplifier (TMA)).
- Connect the 6413A RF Out port to the Node B's RX Only port (which may be direct on the cabinet, or on a Tower Mounted Amplifier (TMA)).
- Assuming the Node B has already been "Audited" the user will now be able to perform a Receiver Test such as Reference Sensitivity or Absolute Reference Sensitivity from the Receiver Tests menu.

## 3. MEASURING RECEIVER SENSITIVITY OF NODE B USING FULL RECEIVER DIVERSITY

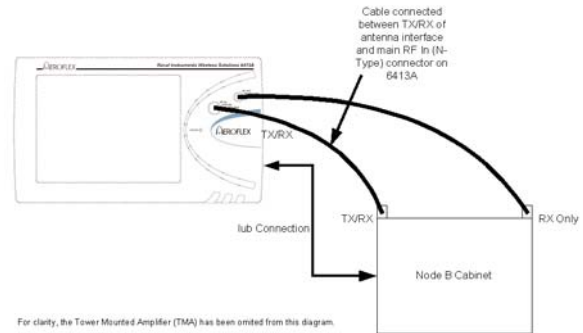

Figure 3: Shows RF and Iub Connections. Full Receiver Diversity

Note: The typical RF OUT (TNC) power level is greater than the Duplex (N-type) power level by +1.3 dB +/-0.8 dB at 1710-2200 MHz or by +1.0 dB +/-0.5 dB at 800-960 MHz.

### Test Method

The test method assumes that the user is able to generally configure the 6413A and the Node B to allow the 6413A to audit the Node B and enter "Link Established" mode.

- Configure the 6413A to test in "Duplex" mode via the Main Menu à Options screen.
- Connect the 6413A main N-Type RF In/Duplex port to the TX/RX (Duplex) port of the antenna interface of the Node B (which may be direct on the cabinet, or on a Tower Mounted Amplifier (TMA)).
- Connect the 6413A RF Out port to the Node B's RX Only port (which may be direct on the cabinet, or on a Tower Mounted Amplifier (TMA)).
- Assuming the Node B has already been "Audited" the user will now be able to perform a Receiver Test such as Reference Sensitivity or Absolute Reference Sensitivity from the Receiver Tests menu.

**4. RECEIVER SENSITIVITY OF EITHER RECEIVER WHERE NO DUPLEXER IS PRESENT OR IS BYPASSED (SIMPLEX OPERATION).**

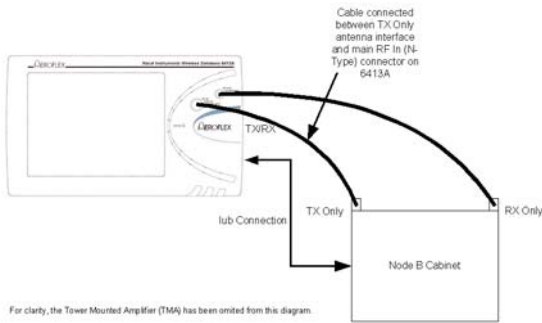

Figure 4: Shows RF and Iub Connections. Simplex Operation

**Test Method**

The test method assumes that the user is able to generally configure the 6413A and the Node B to allow the 6413A to Audit the Node B and enter "Link Established" mode.

1. Configure the 6413A to test in "Simplex" mode via the Main Menu à Options screen.
2. Connect the 6413A main N-Type RF In/Duplex port to the TX/RX (Duplex) port of the antenna interface of the Node B (which may be direct on the cabinet, or on a Tower Mounted Amplifier (TMA)).
3. Connect the 6413A RF Out port to the Node B's RX Only port (which may be direct on the cabinet, or on a Tower Mounted Amplifier (TMA)).
4. Assuming the Node B has already been "Audited" the user will now be able to perform a Receiver Test such as Reference Sensitivity, or Absolute Reference Sensitivity from the Receiver Tests menu.

**CHINA Beijing**  
Tel: [+86] (10) 6539 1166  
Fax: [+86] (10) 6539 1778

**CHINA Shanghai**  
Tel: [+86] (21) 5109 5128  
Fax: [+86] (21) 5150 6112

**FINLAND**  
Tel: [+358] (9) 2709 5541  
Fax: [+358] (9) 804 2441

**FRANCE**  
Tel: [+33] 1 60 79 96 00  
Fax: [+33] 1 60 77 69 22

**GERMANY**  
Tel: [+49] 8131 2926-0  
Fax: [+49] 8131 2926-130

**HONG KONG**  
Tel: [+852] 2832 7988  
Fax: [+852] 2834 5364

**INDIA**  
Tel: [+91] 80 5115 4501  
Fax: [+91] 80 5115 4502

**KOREA**  
Tel: [+82] (2) 3424 2719  
Fax: [+82] (2) 3424 8620

**SCANDINAVIA**  
Tel: [+45] 9614 0045  
Fax: [+45] 9614 0047

**SPAIN**  
Tel: [+34] (91) 640 11 34  
Fax: [+34] (91) 640 06 40

**UK Burnham**  
Tel: [+44] (0) 1628 604455  
Fax: [+44] (0) 1628 662017

**UK Cambridge**  
Tel: [+44] (0) 1763 262277  
Fax: [+44] (0) 1763 285353

**UK Stevenage**  
Tel: [+44] (0) 1438 742200  
Fax: [+44] (0) 1438 727601  
Freephone: 0800 282388

**USA**  
Tel: [+1] (316) 522 4981  
Fax: [+1] (316) 522 1360  
Toll Free: 800 835 2352

As we are always seeking to improve our products, the information in this document gives only a general indication of the product capacity, performance and suitability, none of which shall form part of any contract. We reserve the right to make design changes without notice. All trademarks are acknowledged. Parent company Aeroflex, Inc. ©Aeroflex 2006.

[www.aeroflex.com](http://www.aeroflex.com)  
[info-test@eroflex.com](mailto:info-test@eroflex.com)



Our passion for performance is defined by three attributes represented by these three icons: solution-minded, performance-driven and customer-focused.