

## Model 8314-1 Model 8314-2 WLAN System Simulator

2.0 to 4.0 GHz  
2.0 to 6.0 GHz



*Simulate Connectivity over Distance & Speed*



### Description

This specialized subsystem is used to simulate the connectivity between a mobile unit running along a line of 3 base stations spaced from 250 to 1000 meters apart. The test subsystem is able to simulate the variation of the RF signal from the base stations reaching the mobile (as well as the signal from the mobile reaching the base stations) when the mobile is moving at speeds of up to 250 km/h. Several variations of this have been developed and produced.

The simulator attenuates the simulated Base Station signal through three independent attenuators, then combines the signals. Each attenuator has a dynamic range of 60 dB in 1 dB steps. The operation of the unit is via a RS232 interface, ASCII commands can input parameters into the controller. Upon receiving a trigger the controller executes the program to simulate the link loss to all three Base stations as seen from the mobile transceiver.

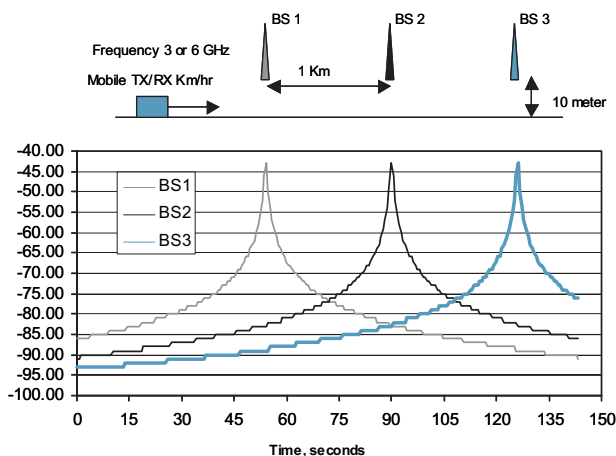

*Calculated signal level from each Base Station.*

*(mobile unit moving at 100 km/hr)*

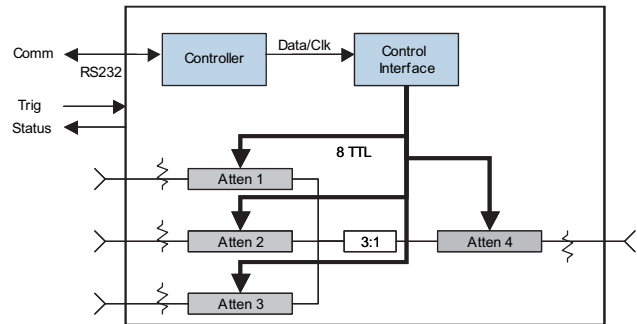

Figure 1. RF Simulator Block Diagram

**TRIGGER:** The signal to begin a run can be either a hardware based trigger generated external from the controller, or via RS232 command. If it is desirable to synchronize the beginning of a train run with other external hardware/ software, a hardware based trigger is recommended. The controller will also output a status signal to indicate that the train is running. Once triggered, this signal is active for the duration of the run.

**OPERATOR CONTROLLED PARAMETERS:** Using the RS-232 control interface the operator has the ability to control the following parameters to set up any mobile unit simulation:

- /// Base Station Positions (X meters, A station, B station, C station, + offset from the track), 0-3000 meters for station positions and 10-100 meters for offset from the track.
- /// Mobile Transceiver Start/Stop Position (x , y meters): 0-10, 000 meters.
- /// Mobile Velocity (Y km/hr): 0-250 km/hr
- /// Time Resolution (1,10,100,1000 mS or auto to fill memory)
- /// Frequency: 2 to 6 GHz
- /// Ant Gain for Mobile and Base Station
- /// Transmitter Antenna Gain: -10 to +10 dB  
Receiver Antenna Gain: -10 to +10 dB
- /// Loop Command: Used to simulate the train running in a continuous loop.

## Specifications

SPECIFICATION	DESCRIPTION	
<b>Input Power Requirements</b>	ac	100 to 240 Vac, 50/60 Hz, 50 Watts
<b>Environmental</b>	Operating Temperature: Storage Temperature: Humidity: Altitude:	0 to +50°C 67° to +167 °F (-55° to +75°C) 96% 40,000' (12,192M)
<b>RS-232 Bus</b>	Connector: Signals: Baud Rates: Data Bits: Handshaking: Parity: Indicators:	9-pin male D TXD, RXD, RTS, CTS, DTR, GND 2400, 9600, 19200, and 38400 8 None, RTS/CTS, XON/XOFF None, Odd, Even Tx (Transmit) and Rx (Receive)
<b>RF Characteristics</b>	Attenuator (Qty 4): Attenuation Range/Step Size: Incremental Attenuation Accuracy: Frequency:  Configuration: Impedance: Insertion Loss: RF Input Power (P1dB): RF Connector: VSWR: Port to Point Isolation:	Pin diode design 0-63.75 dB/ 0.25 dB step +5% of selected value Model 8314-1: 2.0 - 4.0 GHz Model 8314-2: 2.0 - 6.0 GHz  3 inputs, 1 output 50 ohm 27 dB +25 dBm N Female 1.75:1 Target >40 dB

1. RS-232 can be used with standard PC serial port for short and medium distances (up to approximately 50 ft).

## Physical Dimensions

