

Programmable Attenuators



Model 3200T

Model 3200T (E Series)

SmartStep® Programmable Attenuators with built-in Microprocessor-Based Driver

dc to 2.0 GHz

dc to 3.0 GHz

1 Watt

For Use with Weinschel 8210A Controller



Features

- /// **Widest Selection of Attenuation Ranges & Steps Sizes**
- /// **Built-In TTL/CMOS Interface Driver Circuitry**
- /// **High Quality Construction and Connectors**
- /// **Special Configurations Available Upon Request**
 - Custom Cell/Step Size Configurations
 - 3.0 GHz and Higher Frequencies

Description

This line of intelligent programmable step attenuators with a built-in digital interface are designed to simplify the control and integration of these devices into subsystem and bench applications. This series of Programmable Step Attenuators is designed for use in automatic test equipment and OEM systems operating in the dc to 3 GHz frequency range. These models are available in many standard attenuation ranges and cell configurations. Each cell contains a double-pole, double-throw relay that provides a minimum loss or attenuated path for the RF signal.

Microstrip circuitry and special compensation techniques produce flat attenuation versus frequency characteristics. The microstrip construction, using thick-film circuit elements, ensures product uniformity. To minimize RF leakage, the 3200T Series Attenuators are provided with gold-plated contact areas and feedthrough filters at each control terminal.

Specifications

NOMINAL IMPEDANCE: 50 Ω

FREQUENCY RANGE:

dc to 2.0 GHz: 3200T-1, 3200T-2, 3201T-1, 3201T-2, 3205T-1, 3205T-2, 3205T-3, 3206T-1, 3209T-1

dc to 3.0 GHz: 3200T-1E, 3200T-2E, 3201T-1E, 3205T-3E, 3206T-1E, 3209T-1E

CELL CONFIGURATIONS:

Model Number	NO. Cells	Attenuation Range/Steps (dB)	Cell Increments (dB)
3200T-1 3200T-1E	8	127/1	1, 2, 4, 8, 16, 32, 64*
3200T-2 3200T-2E	8	63.75/0.25	0.25, 0.5, 1, 2, 4, 8, 16, 32
3201T-1 3201T-1E	5	31/1	1, 2, 4, 8, 16
3201T-2	5	120/10	10, 20, 30, 60**
3205T-1	4	70/10	10, 20, 20, 20
3205T-2	4	55/5	5, 10, 20, 20
3205T-3 3205T-3E	4	1.5/0.1	0.1, 0.2, 0.4, 0.8
3206T-1 3206T-1E	6	63/1	1, 2, 4, 8, 16, 32
3209T-1 3209T-1E	10	64.5/0.1	0.1, 0.2, 0.4, 0.8, 1, 2, 4, 8, 16, 32

*64 dB cell comprised of two 32 dB cells
**60 dB cell comprised of two 30 dB cells

MAXIMUM SWR:

Freq Range (GHz)	3200T-1 3200T-2	3200T-1E 3200T-2E	3201T-X 3205T-X 3206T-X	3201T-1E 3205T-3E 3206T-1E	3209T-1	3209T-1E
dc - 0.2	1.30	1.25	1.30	1.25	1.35	1.35
0.2 - 1	1.25	1.25	1.25	1.25	1.35	1.35
1 - 2	1.35	1.25	1.35	1.25	1.35	1.35
2 - 3	---	1.40	---	1.35	---	1.45

INCREMENTAL ATTENUATION ACCURACY:

Frequency Range (GHz)	Accuracy
dc - 0.5	± 0.2 dB or 0.5%
0.5 - 1	± 0.2 dB or 1.0%
1 - 3	± 0.3 dB or 2.0%

MONOTONICITY: dc to 3.0 GHz

INCREMENTAL TEMPERATURE COEFFICIENT:

30 and 32 dB Cells: 0.00005 dB/dB/°C
All other cells: 0.00002 dB/dB/°C

Specifications - Con't

MAXIMUM INSERTION LOSS (dB):									
Frequency Range (GHz)	3200T-1 3200T-2	3200T-1E 3200T-2E	3201-1 3201-2	3205T-X	3201T-1E 3205T-3E	3206T-1	3206T-1E	3209T-1	3209T-1E
dc - 0.5	2.80	2.00	1.80	1.80	1.25	2.00	1.50	3.50	3.00
0.5 - 1.0	3.50	2.70	2.40	2.30	1.75	2.70	2.00	4.50	3.50
1.0 - 1.5	4.25	3.00	3.00	2.80	2.25	3.30	2.50	5.60	4.00
1.5 - 2.0	4.75	3.50	3.75	3.30	2.50	4.00	2.80	6.70	4.50
2.0-3.0	---	4.30	---	---	3.40	---	3.70	---	5.50

POWER RATING: 1 watt average to 25°C ambient temperature, derated linearly to 0.25 watt @ 71°C. 50 watts peak (5 µsec pulse width; 1% duty cycle)

POWER COEFFICIENT: < 0.005 dB/dB/watt

RATED SWITCH LIFE: 5 million cycles operations per cell @ 0 dBm

CYCLING RATE: 5 Hz maximum per relay

DRIVER INTERFACE:

Input Supply Voltage: +12.0 to +15. V
Control Signals: TTL/CMOS compatible
Interface Modes: parallel / serial

DC Characteristics (at 25 °C):

Parameter	Specification
V _{IL} Low-level input V:	-0.5V min, 0.8V max
V _{IH} High-level input V:	2.0V min, 5.25V max
I _{PU} Pullup current	50 µA min, 400 µA max
V _{IN} Supply Voltage:	+12.0 to +15.0V
I _{IN} Supply current:	25 mA
(digital section)	
I _{CELL} Supply current:	15 mA (2 GHz Units)
(per cell) continuous	30 mA (3 GHz Units)

TEMPERATURE RANGE (Operating): -20°C to +70°C

TEST DATA: Test data is available at additional cost.

CONNECTORS: SMA female connectors per MIL-STD-348 interface dimensions - mate nondestructively with MIL-C-39012 connectors.

INTERFACE CONNECTOR: 14 pin .025 square post header on .1 center. Mates with Amp connector 746285-2 or equivalent.

CONSTRUCTION:

Housing: Aluminum
Connectors: Stainless steel body and beryllium copper contacts.

WEIGHT:	3200T-X	165 g (8.4 oz)
	3201T-X	132 g (7.3 oz)
	3205T-X	132 g (7.3 oz)
	3206T-X	132 g (7.3 oz)
	3209T-X	218 g (9.7 oz)

ACCESSORIES

Programmable Attenuator/Switch Controller: The Model 8210A Programmable Attenuator/Switch Controller provides a flexible, low cost solution for the operation of programmable step attenuators and other electromechanical devices under computer control. Designed to interface to Aeroflex / Weinschel's intelligent programmable attenuators, the 8210A represents a new concept in device control applications for bench test and subsystem designs. The 8210A provides a high-level interface from various industry standard communications interfaces, including IEEE-488 and RS232/RS422/RS485, to the programmable attenuator's serial Driver Interface Bus.

CONTROL CONFIGURATION

These programmable attenuators feature an internal microcontroller-based driver that provides a TTL-level digital interface for control of the attenuator relays.

This card simplifies operation and interfacing requirements, while at the same time providing for greatly enhanced flexibility over past designs. User-selectable modes of operation include both parallel and serial bus. The parallel mode provides a simple, one-bit per relay on/off control with internal pullups for use primarily in single attenuator applications. This mode allows the attenuator to be controlled via a variety of methods, such as a TTL-level digital output port, or mechanical toggle switches. The device bus provides a two-wire serial bus structure and protocol for connecting a number of devices to a single host control interface, suitable for use in larger system and sub-system applications. The digital interface contains non-volatile configuration memory that is used to hold a wide variety of attenuator and driver-dependent parameters, including serial number, attenuator cell dB values, relay configurations, and switching requirements, which are all accessible via the digital interface.

In either operational mode, the microcontroller enters an idle condition during periods of inactivity, turning off all on-board clocks, reducing EMI concerns, and lowering power consumption. On-board regulation for the digital circuitry allows the attenuator to operate from a single input supply voltage.

Programmable Attenuators



PHYSICAL DIMENSIONS:

Model 3200T, 3201T, 3205T, & 3206T:

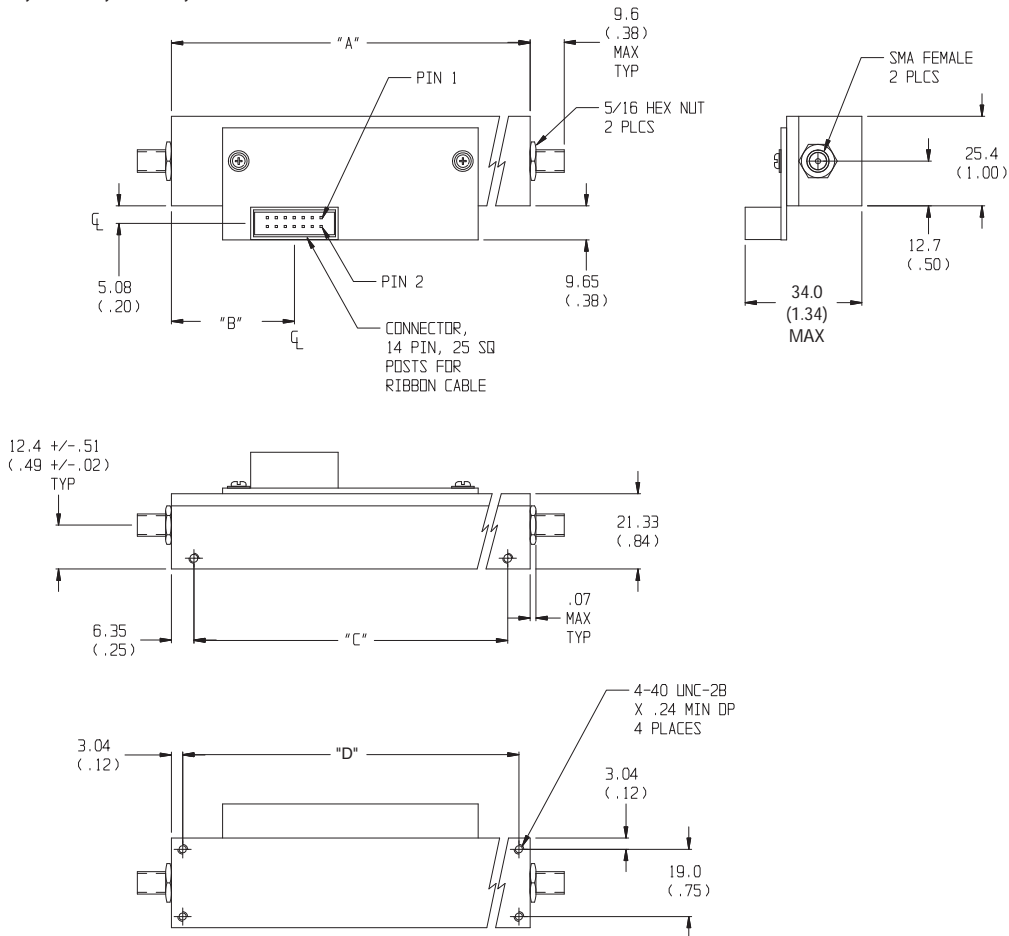

Model No.	No. Cells	A	B	C	D
3200T-X	8	101.6 (4.0)	31.8 (1.25)	88.9 (3.50)	95.2 (3.75)
3201T-X	5/4	76.2 (3.00)	19.1 (0.75)	63.5 (2.50)	69.8 (2.75)
3205T-X	4	72.4 (2.85)	19.1 (0.75)	46.2 (1.82)	52.6 (2.07)
3206T-X	6	81.3±0.5 (3.20±0.02)	21.46 (0.85)	68.6 (2.70)	75.18 (2.96)

Model 3209T:

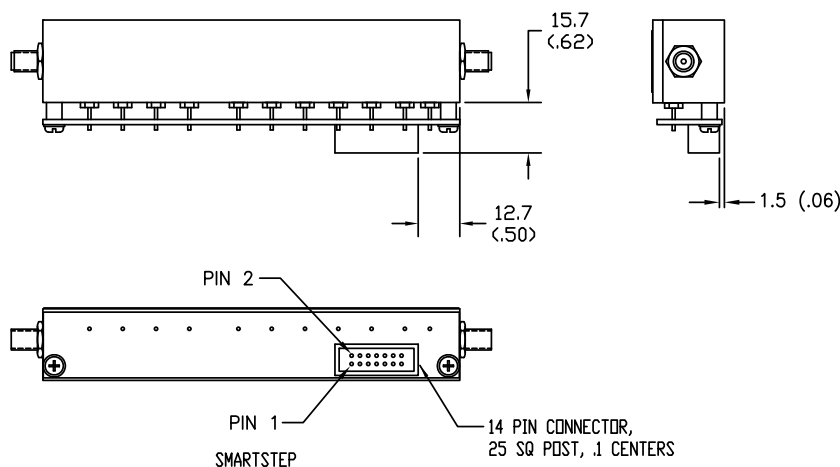

CONN SIGNAL DES

J3-14	N/A
J3-13	N/A
J3-12	N/A
J3-11	N/A
J3-10	N/A
J3-9	N/A
J3-8	N/A
J3-7	N/A
J3-6	N/A
J3-5	N/A
J3-4	GND
J3-3	GND
J3-2	+V
J3-1	+V

SMARTSTEP SYSTEM ONLY
NO PARALLEL MODE OPERATION

NOTE: All dimensions are given in mm (inches) and are maximum, unless otherwise specified.