

## Model 1593 Broadband Resistive Power Splitter (Matching)

dc to 26.5 GHz  
1 Watt

Subminiature, 3.5mm Connectors

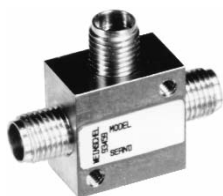

### Features

These resistive power splitters are intended for RF and wireless applications in which one of the two outputs is included in a leveling loop or is used as a reference in a ratio system, for the purpose of providing an output signal whose source impedance is essentially matched to 50Ω. Some examples are:

- /// A dual channel insertion loss measuring system (ratio).
- /// A parallel IF substitution insertion loss measuring system (ratio or ALC loop).
- /// A precision power source (ratio or ALC loop).

### Specifications

**NOMINAL IMPEDANCE:** 50 Ω

**FREQUENCY RANGE:** dc to 26.5 GHz

**INSERTION LOSS:** 6 dB nominal, 8.5 dB maximum  
(Between input and either output)

**MAXIMUM INPUT POWER:** 1.0 watts CW (Input Connector only)

#### AMPLITUDE & PHASE TRACKING (Maximum):

Frequency (GHz)	Tracking	
	Amplitude	Phase
dc - 26.5	<0.25 dB	<4°

#### MAXIMUM INPUT SWR:

Frequency (GHz)	Maximum SWR
dc - 26.5	1.25

#### EQUIVALENT OUTPUT SWR (Port 2 & 3):

Frequency (GHz)	Maximum SWR
dc - 18	1.25
18 - 26.5	1.35

\*When used in a leveling or ration system.

#### TEMPERATURE RANGE:

Operating: -55°C to +85°C  
Storage: -55°C to +125°C

**TEST DATA:** Insertion Loss, SWR, and Tracking measurements performed across the frequency band. Test data available at additional cost.

**CONNECTORS:** Female 3.5mm connectors all ports --mate nondestructively with SMA, 2.92mm and other 3.5mm connectors.

**WEIGHT:** 25 g (0.9 oz) maximum

#### PHYSICAL DIMENSIONS:

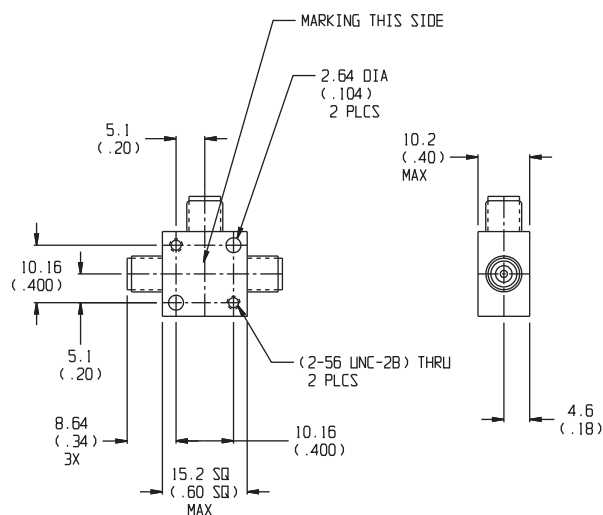

NOTE: All dimensions are given in mm (inches) and are maximum, unless otherwise specified.