

Operation & Installation Manual



Model 8310 SmartStep[®] Programmable Attenuator Units w/Ethernet

This documentation may not be reproduced in any form, for any purpose unless authorized in writing by Aeroflex / Weinschel, Inc.



© Aeroflex / Weinschel, Inc.
Frederick, Maryland
2008-2011

SAFETY SUMMARY

DEFINITIONS.

The following definitions apply to WARNINGS, CAUTIONS, and NOTES found throughout this manual.



An operating or maintenance procedure, practice, statement, condition, etc., which, if not strictly observed, could result in injury and/or death of personnel. Do not proceed beyond a WARNING symbol until all the indicated conditions have been fully understood and/or met.



An operating or maintenance procedure, practice, statement, condition, etc., which, if not strictly observed, could result in damage or destruction of the equipment or long-term health hazards to personnel. Do not proceed beyond a CAUTION symbol until all the indicated conditions have been fully understood and/or met.

NOTE

An essential operating or maintenance procedure, condition, or statement that must be highlighted.

GENERAL PRECAUTIONS.

The following are general precautions that are not related to any specific procedure and, therefore, do not appear elsewhere in this publication. These are precautions that personnel must understand and apply during various phases of instrument operation or service.



- Potentially lethal voltages are present in this instrument. Serious shock hazards from voltages above 70 volts may exist in any connector, chassis, or circuit board. Observe the following precautions:

- To minimize shock hazard, the instrument chassis must be connected to an electrical ground. Using the supplied three-conductor power cable ensures that the instrument can be firmly connected to the ac power source and electrical ground at a grounded power outlet. If using a 3-2 wire adapter be sure to connect the ground lead to earth ground.
- Use the buddy system any time work involving active high voltage components is required. Turn OFF the power before making/breaking any electrical connection. Regard any exposed connector, terminal board, or circuit board as a possible shock hazard. DO NOT replace any component or module with power applied.
- If test conditions to live equipment are required, ground the test equipment before probing the voltage or signal to be tested.
- Personnel working with or near high voltage should be familiar with modern methods of resuscitation.
- DO NOT wear jewelry (rings, bracelets, metal watches, and/or neck chains) while working on exposed equipment. Be very cautious about using hand tools near exposed backplanes, bus bars, and/or power supply terminals. Use properly insulated tools. When making test connections to the power supply terminals and bus bars, use only insulated probe tips.
- Verify that the instrument is set to match the available line voltage and the correct fuse is installed.
- DO NOT install substitute parts or perform any unauthorized modification to this instrument. Contact Weinschel Corporation to acquire any information on replacement parts or returning the instrument for repair. Unauthorized modification can cause injury to personnel and/or destruction of the instrument.
- Operating personnel must not remove instrument covers. Component replacement or adjustments MUST BE performed by qualified service personnel.
- DO NOT operate the instrument near or in the presence of flammable gases or fumes.

DETAILED PRECAUTIONS.

The following WARNINGS, CAUTIONS and NOTES appear throughout the text of this manual and are repeated here for emphasis.



CAUTION

- All procedures and/or steps identified as  must be followed exactly as written and according to industry accepted ESDS device handling procedures. Failure to comply WILL RESULT in ESDS damage.
- DO NOT use a nylon bristle brush in the solvent as the bristles may dissolve and cause damage to the circuit card or component.
- DO NOT use ultrasonic cleaning on parts or assemblies containing electrical or electronic components.
- DO NOT bend pins of electrical connectors when using fiber-bristle brush.
- Compressed air used for cleaning and/or drying can create airborne particles that may enter the eye. Goggles/faceshields should be worn. DO NOT direct air stream towards self or other personnel. Pressure should be restricted to a maximum of 15 psi to avoid personal injury.
- Under no circumstances should a wire brush, steel wool, or abrasive compound be used on any surface. Using these items will cause extensive damage to the instruments surface.

NOTE

DO NOT return any instrument or component to Weinschel Corporation without receiving prior factory authorization.

SAFETY SYMBOLS.

The following symbols are used to identify safety hazards found throughout this publication and/or located on the instrument.

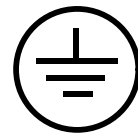
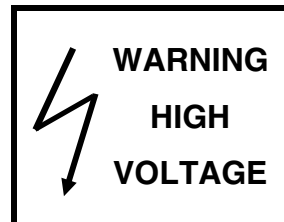

TABLE OF CONTENTS

1. GENERAL INFORMATION	5
1-1. PURPOSE	5
1-2. SCOPE	5
1-3. EQUIPMENT DESCRIPTION	5
1-4. USING THE 8310-XXX-X	6
1-5. UNPACKING AND INSPECTION	6
1-6. RESHIPMENT INSTRUCTIONS	6
1-7. STORAGE INSTRUCTIONS	6
1-8. RELATED MANUALS	7
1-9. ELECTROSTATIC DISCHARGE SENSITIVE (ESD)	7
1-10. ABBREVIATIONS & ACRONYMS	7
1-11. SAFETY CONSIDERATIONS	7
1-12. POWER REQUIREMENTS	7
1-13. ENVIRONMENTAL REQUIREMENTS	7
2. SPECIFICATIONS	8-10
3. INSTALLATION	11
3-1. RACKMOUNTING	11
3-2. INTIAL SETUP	11
3-3. INPUT/OUTPUT OPTIONS	11-12
3-3.1. POWER ENTRY MODULE ASSEMBLY	12
3-3.2. CHANNEL PORT CONNECTORS	12
3-3.3. MODE SELECT SWITCH	12
4. FRONT PANEL CONTROLS & INDICATORS	13
5. REMOTE OPERATION	14
5-1. COMMUNICATIONS INTERFACE	14-15
5-1.1. OPERATING MODES	15
5-1.2. SERIAL PORT SETUP	15
5-1.3. ETHERNET SETUP	15
5-1.3.1. DEVICEINSTALLER	15
5-1.3.2. SERIAL PORT LOGIN	16
5-1.3.3. ARP AND TELNET	17
5-1.3.4. DHCP	17
5-1.3.5. AUTOIP	17-18
5-1.3.6. BOOTP	18
5-1.3.7. DEVICE SERVER SETUP	18
5-1.3.8. EXAMPLE SETUP USING THE SERIAL PORT	18-22
5-2. SERIAL OPERATION	22-23
5-2.1. RS-232 OPERATION	23
5-3. STATUS REPORTING	24-25
5-4. GENERAL SYNTAX STRUCTURE	25
5-4.1. SYNTAX OF QUERIES	25
5-4.2. SYNTAX OF COMMANDS	25-26

5-4.3. OUTPUT DATA FORMAT	26
5-4.4. NOTATIONAL CONVENTION.....	26
5-5. COMMON COMMANDS	27-28
5-6. GENERAL COMMANDS	29-30
6.. MAINTENANCE.....	31
6-1. INSPECTION	31
6.2. PREVENTIVE MAINTENANCE.....	31
6.3. SPECIAL CLEANING INSTRUCTIONS	31
6-3.1. MICROWAVE COAXIAL CABLE ASSEMBLIES	31
6-3.2. CIRCUIT CARDS AND MODULES	31
6-3.3. MACHINED SURFACES AND HARDWARE	32
6-3.4. CHASIS CLEANING.....	32
6-3.5. CONNECTOR CLEANING	32
6.4. LINE VOLTAGE FUSE REPLACEMENT	33
7. REPLACABLE PARTS LIST.....	34
7-1. UNDERSTANDING REFERENCE DESIGNATORS	34
7-2. ORDERING INFORMATION.....	34
7-3. DRAWING NUMBER.....	34
7-4. REPLACABLE PARTS LIST	34
7-4.1. REFERENCE DESIGNATOR.....	34
7-4.2. DESCRIPTION.....	34
7-4.3. PART NUMBER	34
7-4.4. VENDOR PART NUMBER	34
7-5.5. CAGE CODE.....	34
7-4.6. ASSEMBLY AND COMPONET LOCATION.....	34
MODEL 8310-1-FN / -RN, ATTENUATOR UNIT ASSEMBLY REPLACEABLE PARTS LIST (P/N 193-7001-4)	35
MDEL 8310-1-2-FN / -RN, ATTENUATOR UNIT ASSEMBLY REPLACEABLE PARTS LIST (P/N 193-7002-5)	35
MODEL 8310-1-3-TN ATTENUATOR UNIT ASSEMBLY REPLACEABLE PARTS LIST (P/N 193-7001-6).....	36
MODEL 8310-2-FN / -RN, ATTENUATOR UNIT ASSEMBLY REPLACEABLE PARTS LIST (P/N 193-7002-3)	37
MODEL 8310-2-2-FN / -RN, ATTENUATOR UNIT ASSEMBLY REPLACEABLE PARTS LIST (P/N 193-7002-4)	37
MODEL 8310-35-FN / -RN ATTENUATOR UNIT ASSEMBLY REPLACEABLE PARTS LIST (P/N 193-7035-9).....	38
MODEL 8310-35-2-FN / -RN ATTENUATOR UNIT ASSEMBLY REPLACEABLE PARTS LIST (P/N 193-7035-10).....	38
MODEL 8310-35-3-TN ATTENUATOR UNIT ASSEMBLY REPLACEABLE PARTS LIST (P/N 193-7035-11).....	39
MODEL 8310-35-4-TN ATTENUATOR UNIT ASSEMBLY REPLACEABLE PARTS LIST (P/N 193-7035-12).....	39
MODEL 8310-35-F / R-EN, ATTENUATOR UNIT ASSEMBLY REPLACEABLE PARTS LIST (P/N 193-7035-13).....	40
MODEL 8310-35-2-F / R -EN, ATTENUATOR UNIT ASSEMBLY REPLACEABLE PARTS LIST (P/N 193-7035-14).....	40
MODEL 8310-35-3-T-EN, ATTENUATOR UNIT ASSEMBLY REPLACEABLE PARTS LIST (P/N 193-7035-15)	41
MODEL 8310-35-4-T-EN, ATTENUATOR UNIT ASSEMBLY REPLACEABLE PARTS LIST (P/N 193-7035-16)	41
MODEL 8310-36-FN / -RN ATTENUATOR UNIT ASSEMBLY REPLACEABLE PARTS LIST (P/N 193-7036-8).....	42
MODEL 8310-36-2-FN / -RN ATTENUATOR UNIT ASSEMBLY REPLACEABLE PARTS LIST (P/N 193-7036-9).....	42
MODEL 8310-36-3-TN ATTENUATOR UNIT ASSEMBLY REPLACEABLE PARTS LIST (P/N 193-7036-10).....	43
MODEL 8310-36-F / R-EN, ATTENUATOR UNIT ASSEMBLY REPLACEABLE PARTS LIST (P/N 193-7038-11).....	44
MODEL 8310-36-2-F / R -EN, ATTENUATOR UNIT ASSEMBLY REPLACEABLE PARTS LIST (P/N 193-7036-12).....	44
MODEL 8310-36-3-EN, ATTENUATOR UNIT ASSEMBLY REPLACEABLE PARTS LIST (P/N 193-7036-13).....	45
MODEL 8310-38-FN / -RN ATTENUATOR UNIT ASSEMBLY REPLACEABLE PARTS LIST (P/N 193-7038-9).....	45
MODEL 8310-38-2-FN / -RN ATTENUATOR UNIT ASSEMBLY REPLACEABLE PARTS LIST (P/N 193-7038-10).....	46

MODEL 8310-38-3-TN ATTENUATOR UNIT ASSEMBLY REPLACEABLE PARTS LIST (P/N 193-7038-11).....47

MODEL 8310-38-4-TN, ATTENUATOR UNIT ASSEMBLY REPLACEABLE PARTS LIST (P/N 193-7038-12).....47

MODEL 8310-38-F / R-EN, ATTENUATOR UNIT ASSEMBLY REPLACEABLE PARTS LIST (P/N 193-7038-13).....48

MODEL 8310-38-2-F / R -EN, ATTENUATOR UNIT ASSEMBLY REPLACEABLE PARTS LIST (P/N 193-7038-14).....48

MODEL 8310-38-3-EN, ATTENUATOR UNIT ASSEMBLY REPLACEABLE PARTS LIST (P/N 193-7038-15).....49

MODEL 8310-38-4-EN, ATTENUATOR UNIT ASSEMBLY REPLACEABLE PARTS LIST (P/N 193-7038-16).....49

MODEL 8310-138-FN / -RN, ATTENUATOR UNIT ASSEMBLY REPLACEABLE PARTS LIST (P/N 193-7138-5).....50

MODEL 8310-138-2-FN / -RN, ATTENUATOR UNIT ASSEMBLY REPLACEABLE PARTS LIST (P/N 193-7138-6).....51

MODEL 8310-138-3-TN, ATTENUATOR UNIT ASSEMBLY REPLACEABLE PARTS LIST (P/N 193-7138-7).....52

MODEL 8310-138-4-TN, ATTENUATOR UNIT ASSEMBLY REPLACEABLE PARTS LIST (P/N 193-7138-8).....53

MODEL 8310-352-FN / -RN, ATTENUATOR UNIT ASSEMBLY REPLACEABLE PARTS LIST (P/N 193-7403-5).....54

MODEL 8310-352-2-FN / -RN, ATTENUATOR UNIT ASSEMBLY REPLACEABLE PARTS LIST (P/N 193-7403-6).....55

MODEL 8310-352-3-TN, ATTENUATOR UNIT ASSEMBLY REPLACEABLE PARTS LIST (P/N 193-7403-7).....56

MODEL 8310-352-4-TN, ATTENUATOR UNIT ASSEMBLY REPLACEABLE PARTS LIST (P/N 193-7403-8).....57

ASSY, BASE UNIT W/ETHERNET (+15V) PARTS LIST (P/N 193-8034-3).....58

ASSY, BASE UNIT W/ETHERNET (+5V) PARTS LIST (P/N 193-8034-4).....59

8. CONTACTING AEROFLEX / WEINSCHEL..... 60

9. AEROFLEX / WEINSCHEL WARRANTY 60

10. ASSEMBLY/WIRING DIAGRAMS

MODEL 8310-1-X-XN ASSEMBLY DRAWING 193-7002-4A THRU -6A

MODEL 8310-2-X-XN ASSEMBLY DRAWING 193-7002-3A, -4A

MODEL 8310-35-X-XN ASSEMBLY DRAWING 193-7035-9A THRU -16A

MODEL 8310-36-X-XN ASSEMBLY DRAWING 193-7036-8A THRU -13A

MODEL 8310-38-X-XN ASSEMBLY DRAWING 193-7038-9A THRU -16A

MODEL 8310-138-X-XN ASSEMBLY DRAWING 193-7138-5A THRU -8A

MODEL 8310-352-X-XN ASSEMBLY DRAWING 193-7403-5A THRU -8A

BASE UNIT W/ETHERNET (+15 V) ASSEMBLY DRAWING..... 193-8034-3A

MODEL 8310 W/ETHERNET (+15 V) WIRING DIAGRAM 193-8135A

BASE UNIT W/ETHERNET (+5 V) ASSEMBLY DRAWING..... 193-8034-4A

MODEL 8310 W/ETHERNET (+5 V) WIRING DIAGRAM 193-8136A

MODEL 8310 W/ETHERNET, 8310-X-X-XN SPECIFICATION, ICD DRAWING 089-4051A

MODEL 8310 (75 OHM) W/ETHERNET, 8310-1-X-XN SPECIFICATION, ICD DRAWING 089-4052A

MODEL 8310-138-X-XN SPECIFICATION, ICD DRAWING 089-4066A

MODEL 8310-352-X-XN SPECIFICATION, ICD DRAWING 089-4065A

9. GENERAL INFORMATION:

1-1 PURPOSE: This manual contains setup and operation information for the Aeroflex / Weinschel's 8310-XXX-XN Series of Programmable Attenuator Units with Ethernet Control. The manual also provides component location, reference designators, part numbers, and nomenclature to identify all the assemblies and sub-assemblies of the Attenuator Unit.

1-2 SCOPE: This manual is to be used in conjunction with the operation and maintenance of an 8310-XXX-XN Series of Programmable Attenuator Units with Ethernet Control. The manual also provides a description of each assembly; assembly parts list; block diagrams; and general maintenance procedures to maintain the instrument.

1-3 EQUIPMENT DESCRIPTION: Aeroflex / Weinschel's 8310-XXX-XN Series of Programmable Attenuator Units with Ethernet Control represents a new concept in programmable attenuation for bench test and subsystem applications. Standard Model 8310-XXX-XN designs house and control various Aeroflex / Weinschel Programmable Attenuator Models (3200T, 3400T, 150T, and 4200 Series) via front panel controls or standard communications interfaces including Ethernet, GPIB (IEEE-488) and RS-232/RS-422/RS485. Special configurations also exist where the RF section is designed to specific customer requirements which can contain to multiple programmable attenuations used in-conjunction with other coaxial devices such as switches, power combiners, directional couplers, and filters creating single or multi-channel subsystems.



1-4 USING THE 8310-XXX-XN: The 8310-XXX-XN Series provides front-panel and computer control for up to four channels of attenuation, RF switching, or other functions. The 8310-XXX-XN combines the features of the Aeroflex / Weinschel 8210A Device Controller with a front panel user interface to form a flexible, easy to use solution. Most 8310-XXX-XN Series are single channel configurations where RF signal is routed through either the front or rear mounted Ports A & B connector (Ports A-A if the RF is routed front to rear) to a single or multiple Aeroflex / Weinschel programmable attenuators thus creating CH1 (Channel 1). Note that when a Port is in use the Port indicator will be illuminated. Dual channel units typically use Ports A and B for CH1 and Ports C and D for CH2 (Ports A-A if the RF is routed front to rear for CH1 and Ports B-B for CH2). Multi-channel (3-4) units are generally routed front to rear and configured as follows:

- CH1 Port A (Front) to Port A (Rear)
- CH2 Port B (Front) to Port B (Rear)
- CH3 Port C (Front) to Port C (Rear)
- CH4 Port D (Front) to Port D (Rear)

For specialized configurations refer to supplemental information in the front of this manual for details.

Typically Aeroflex / Weinschel digital attenuators are bi-directional and the RF signal can be applied to either Port connector. Channels can be selected by toggling the front panel CHAN button until the desired CH1-CH4 indicator is illuminated. Repeated depressions of the CHAN key will select the next available channel. The main display will show the current attenuation setting of the channel. A new attenuation setting in dB may be entered using the INCR/DECR or ENTRY keys. The front panel STEP key allows the user to define the attenuation step size used by the INCR and DECR keys. Remember that the attenuation step size (resolution) is limited to the physical size of the internal attenuator cells. For example a 0-70 unit with 10 dB steps can only be adjusted in 10 dB increments but larger increments such as 20, 30, 40 dB can be set using this key.

The REL key allows the user to set relative mode for attenuators. When turned on, the currently displayed attenuation value is used as a reference value from which the attenuation may be set. In this mode, attenuation values may be positive or negative from the reference setting. When REL is turned off, the display returns to the actual attenuation setting for the channel. Refer to Section 5 for more detailed information about the front panel keys and indicators. All 8310-XXX-XN Series functions can also be controlled via standard communications interfaces including Ethernet, GPIB (IEEE-488) and RS-232/RS-422 /RS485. Refer to Section 6 for bus setup and operating instructions when using the 8310-XXX-XN Series in the remote mode.

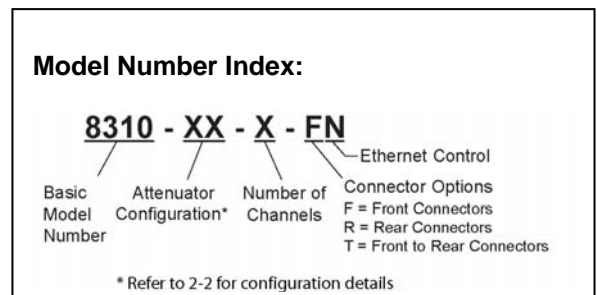

1-5. UNPACKING AND INSPECTION: Upon unpacking the equipment, retain the shipping container and packing material for future shipment for recalibration. Perform the following initial inspection:

- a. Carefully look at the outside of the shipping container for discoloration, stains, charring, or other signs of exposure to excessive heat, moisture, or liquid chemicals. Check for any physical damage to the shipping container such as dents, snags, rips, crushed sections or areas, or similar signs of excessive shock or careless handling.
- b. With the equipment and any accessory package removed from the shipping container, check each item against the packing list or Items Supplied List. If any items are missing, contact the Weinschel Corporation Customer Service Department.
- c. Carefully inspect the equipment looking for dents, deep scratches, damaged or loose connector, or any other
- d. signs of physical abuse or careless handling. If damage is found, forward an immediate request to the delivering carrier to perform an inspection and prepare a concealed-damage report. DO NOT destroy any packing material until it has been examined by an agent of the carrier. Concurrently, report the nature and extent of damage to Weinschel Corporation, giving equipment model and serial numbers, so that necessary action can be taken. Under U.S. shipping regulations, damage claims must be collected by the consignee; DO NOT return the equipment to Aeroflex / Weinschel until a claim for damages has been established.

1-6. RESHIPMENT: Use the best packaging materials available to protect the unit during storage or reshipment. When possible, use the original packing container and cushioning material. If the original packing materials are not available, use the following procedure:

- a. Wrap the storage cases in sturdy paper or plastic;
- b. Place the wrapped storage cases in a strong shipping container and place a layer of shock-absorbing material (3/4 inch minimum thickness) around all sides of the unit to provide a firm cushion and to prevent movement inside the container.
- c. If shipping the unit for service, attach a tag to indicate:
 1. model and serial numbers
 2. service required
 3. description of malfunction
 4. return address
 5. authorization to conduct repairs
 6. return authorization number
- d. Thoroughly seal the shipping container and mark it FRAGILE. Ship to:

Aeroflex / Weinschel, Inc.
 Attn: Customer Service Department
 5305 Spectrum Drive
 Frederick, MD 21703-7362
 or to an authorized sales representative.

1-7. STORAGE: Storage of the Model 8310-XXX-XN *SmartStep*® Attenuator Unit is possible for extended periods without incurring damage to internal circuitry if the 8310-XXX-XN Series is packaged according to the instructions above. The safe limits for storage environment are as follows:

Temperature: 4° to +167 °F (-20° to +75 °C)
Humidity: less than 95% without condensation
Altitude: Up to 40,000 feet



1-8. RELATED MANUALS: The following manuals contain information that may be used in conjunction with this manual to operate, service, or calibrate this instrument.

<u>Manual</u>	<u>Title</u>
H4-1 and H4-2	Federal Supply Code for Manufacturers Cataloging Handbook

1-9. ELECTROSTATIC DISCHARGE SENSITIVE: The equipment documented in this manual contains certain Electrostatic Discharge Sensitive (ESDS) components or parts. Therefore, certain procedures/steps are identified by the use of the symbol . This symbol is used in two ways:



All procedures and/or steps identified as must be followed exactly as written and according to accepted ESDS device handling procedures. Failure to comply **WILL RESULT** in ESDS damage.

- a. When the ESDS symbol is placed between a paragraph number and title  all of that paragraph, including all subparagraphs, is considered ESDS device handling procedure.
- b. When the ESDS symbol is placed between a procedure/step number and the text , all of that procedure is considered an ESDS device handling procedure.

1-10. ABBREVIATIONS AND ACRONYMS: The following list contains abbreviations used throughout this manual. Abbreviations and acronyms that are not listed conform to MIL-STD-12D.

DUT	Device Under Test
ESDS	Electrostatic Discharge Sensitive
DIB	Device Interface Bus
TBD	To Be Determined

1-11. SAFETY CONSIDERATIONS: The Model 8310-XXX-XN Attenuator Unit and all related documentation must be reviewed for familiarization with safety markings and procedures before any operation and/or service. Refer to the SAFETY SUMMARY located at the beginning of this manual for a summary of safety information and procedures. Following these simple safety precautions will ensure safe operation and service of the Attenuator Unit.

1-12. POWER REQUIREMENTS: Aeroflex / Weinschel supplies a detachable power cable (P/N 068-21) to connect a 115 to 230 Vac power source with a frequency between 50 to 60 Hz to the Attenuator Unit. To minimize shock hazard, the instrument chassis must be connected to an electrical ground. Using the supplied three-conductor power cable ensures that the instrument can be firmly connected to the ac power source and electrical ground (safety ground) at a grounded power outlet. Refer to paragraph 3-2 (Initial Setup) before applying any power to the instrument.

1-13. ENVIRONMENTAL REQUIREMENTS: This instrument performs best within its specifications when operated within a controlled environment having an ambient temperature of 0°± 50°C, Relative Humidity of up to 95% non condensing, and a altitude of less than 40,000 feet. Operating beyond these limits can affect the accuracy and performance of the instrument and damage internal circuitry.

2. SPECIFICATIONS:

2-1. GENERAL SPECIFICATIONS:

Input Power Requirements	ac 115 to 230 Vac, 1.6 A, 50/60 Hz, 50 Watts
Environmental	Operating Temperature: 0 to +50°C Storage Temperature: 4° to +167 °F (-20° to +75 °C)
RS-232 (Serial) Bus ⁽¹⁾	Connector: 9-pin male D Signals: TXD, RXD, RTS, CTS, DTR, GND Baud Rates: 2400, 9600, 19200, and 38400 Data Bits: 8 Handshaking: None, RTS/CTS, XON/XOFF Parity: None, Odd, Even Indicators: Tx (Transmit) and Rx (Receive)
Ethernet TC/IP	10/100 Base T Connector: Standard RJ45
RF Characteristics ⁽³⁾	See Model Configuration Tables (pg 8)

NOTES:

1. RS-232 can be used with standard PC serial port for short and medium distances (up to approximately 50 ft).
2. Refer to Individual data sheet (Appendix C) for detailed specifications on internal programmable attenuators.

2-2. CONFIGURATIONSIRF SPECIFICATIONS:*Table 1. 3200T & 150T Series-Mechanical Relay:*

Model No	Attenuator Value	Frequency Range (GHz)	Insertion Loss	SWR	No of Channels	Attenuator Type	Connector Type	Connector Location	Drawing No
8310-1-FN	63/1	dc-1.0 (75 Ω)	6.0 dB max	1.6 max	1	3250T-63	BNC/F	Front	193-7001-4
8310-1-RN	63/1	dc-1.0 (75 Ω)	6.0 dB max	1.6 max	1	3250T-63	BNC/F	Rear	193-7001-4
8310-1-2-FN	63/1	dc-1.0 (75 Ω)	6.0 dB max	1.6 max	2	3250T-63	BNC/F	Front	193-7001-5
8310-1-2-RN	63/1	dc-1.0 (75 Ω)	6.0 dB max	1.6 max	2	3250T-63	BNC/F	Rear	193-7001-5
8310-1-3-TN	63/1	dc-1.0 (75 Ω)	6.0 dB max	1.6 max	2	3250T-63	BNC/F	Front to Rear	193-7001-6
8310-2-FN	63/1	dc-1.0 (75 Ω)	6.75 dB max	2.0 max	1	3250T-63	F/F	Front	193-7002-3
8310-2-RN	63/1	dc-1.0 (75 Ω)	6.75 dB max	2.0 max	1	3250T-63	F/F	Rear	193-7002-3
8310-2-2-FN	63/1	dc-1.0 (75 Ω)	6.75 dB max	2.0 max	2	3250T-63	F/F	Front	193-7002-4
8310-2-2-RN	63/1	dc-1.0 (75 Ω)	6.75 dB max	2.0 max	2	3250T-63	F/F	Rear	193-7002-4
8310-35-FN	127/1	dc-2	6.0 dB max	1.4 max	1	3200T-1	N/F	Front	193-7035-9
8310-35-RN	127/1	dc-2	6.0 dB max	1.4 max	1	3200T-1	N/F	Rear	193-7035-9
8310-35-2-FN	127/1	dc-2	6.0 dB max	1.4 max	2	3200T-1	N/F	Front	193-7035-10
8310-35-2-RN	127/1	dc-2	6.0 dB max	1.4 max	2	3200T-1	N/F	Rear	193-7035-10
8310-35-3-TN	127/1	dc-2	6.0 dB max	1.4 max	3	3200T-1	N/F	Front to Rear	193-7035-11
8310-35-4-TN	127/1	dc-2	6.0 dB max	1.4 max	4	3200T-1	N/F	Front to Rear	193-7035-12
8310-35-F-EN	127/1	dc-3	6.0 dB max	1.4 max	1	3200T-1E	N/F	Front	193-7035-13
8310-35-R-EN	127/1	dc-3	6.0 dB max	1.4 max	1	3200T-1E	N/F	Rear	193-7035-13
8310-35-F-EN	127/1	dc-3	6.0 dB max	1.4 max	2	3200T-1E	N/F	Front	193-7035-14
8310-35-R-EN	127/1	dc-3	6.0 dB max	1.4 max	2	3200T-1E	N/F	Rear	193-7035-14
8310-35-3-T-EN	127/1	dc-3	6.0 dB max	1.4 max	3	3200T-1E	N/F	Front to Rear	193-7035-15
8310-35-4-T-EN	127/1	dc-3	6.0 dB max	1.4 max	4	3200T-1E	N/F	Front to Rear	193-7035-16
8310-36-FN	64.5/0.1	dc-2	8.0 dB max	1.4 max	1	3209T-64.5	N/F	Front	193-7036-8
8310-36-RN	64.5/0.1	dc-2	8.0 dB max	1.4 max	1	3209T-64.5	N/F	Rear	193-7036-8
8310-36-2-FN	64.5/0.1	dc-2	8.0 dB max	1.4 max	2	3209T-64.5	N/F	Front	193-7036-9
8310-36-2-RN	64.5/0.1	dc-2	8.0 dB max	1.4 max	2	3209T-64.5	N/F	Rear	193-7036-9
8310-36-3-TN	64.5/0.1	dc-2	8.0 dB max	1.4 max	3	3209T-64.5	N/F	Front to Rear	193-7036-10
8310-36-F-EN	64.5/0.1	dc-2	8.0 dB max	1.4 max	1	3209T-64.5	N/F	Front	193-7036-11
8310-36-R-EN	64.5/0.1	dc-2	8.0 dB max	1.4 max	1	3209T-64.5	N/F	Rear	193-7036-11
8310-36-2-F-EN	64.5/0.1	dc-2	8.0 dB max	1.4 max	2	3209T-64.5	N/F	Front	193-7036-12
8310-36-2-R-EN	64.5/0.1	dc-2	8.0 dB max	1.4 max	2	3209T-64.5	N/F	Rear	193-7036-12
8310-36-3-T-EN	64.5/0.1	dc-2	8.0 dB max	1.4 max	3	3209T-64.5	N/F	Front to Rear	193-7036-13
8310-37-FN	63.75/0.25	dc-2	6.0 dB max	1.4 max	1	3200T-2	N/F	Front	
8310-37-RN	63.75/0.25	dc-2	6.0 dB max	1.4 max	1	3200T-2	N/F	Rear	
8310-37-2-FN	63.75/0.25	dc-2	6.0 dB max	1.4 max	2	3200T-2	N/F	Front	
8310-37-2-RN	63.75/0.25	dc-2	6.0 dB max	1.4 max	2	3200T-2	N/F	Rear	
8310-37-3-TN	63.75/0.25	dc-2	6.0 dB max	1.4 max	3	3200T-2	N/F	Front to Rear	
8310-37-4-TN	63.75/0.25	dc-2	6.0 dB max	1.4 max	4	3200T-2	N/F	Front to Rear	
8310-38-FN	63/1	dc-2	5.25 dB max	1.4 max	1	3206T-1	N/F	Front	193-7038-9
8310-38-RN	63/1	dc-2	5.25 dB max	1.4 max	1	3206T-1	N/F	Rear	193-7038-9
8310-38-2-FN	63/1	dc-2	5.25 dB max	1.4 max	2	3206T-1	N/F	Front	193-7038-10
8310-38-2-RN	63/1	dc-2	5.25 dB max	1.4 max	2	3206T-1	N/F	Rear	193-7038-10
8310-38-3-TN	63/1	dc-2	5.25 dB max	1.4 max	3	3206T-1	N/F	Front to Rear	193-7038-11
8310-38-4-TN	63/1	dc-3	5.25 dB max	1.4 max	4	3206T-1E	N/F	Front to Rear	193-7038-12
8310-38-F-EN	63/1	dc-2	5.25 dB max	1.4 max	1	3206T-1	N/F	Front	193-7038-13
8310-38-R-EN	63/1	dc-2	5.25 dB max	1.4 max	1	3206T-1	N/F	Rear	193-7038-13
8310-38-2-F-EN	63/1	dc-2	5.25 dB max	1.4 max	2	3206T-1	N/F	Front	193-7038-14
8310-38-2-R-EN	63/1	dc-2	5.25 dB max	1.4 max	2	3206T-1	N/F	Rear	193-7038-14
8310-38-3-T-EN	63/1	dc-2	5.25 dB max	1.4 max	3	3206T-1	N/F	Front to Rear	193-7038-15
8310-38-4-T-EN	63/1	dc-3	5.25 dB max	1.4 max	4	3206T-1E	N/F	Front to Rear	193-7038-16

Table 1, Continued on next page

Table 1. 3200T & 150T Series-Mechanical Relay (Continued):

Model No	Attenuator Value	Frequency Range (GHz)	Insertion Loss	SWR	No. of Channels	Attenuator Type	Connector Type	Connector Location	Drawing Number
8310-201-FN	70/10	dc-18	3.25 dB max	1.75	1	150T-70	Sma/F	Front	
8310-201-RN	70/10	dc-18	3.25 dB max	1.75	1	150T-70	Sma/F	Rear	
8310-201-2-FN	70/10	dc-18	3.25 dB max	1.75	2	150T-70	Sma/F	Front	
8310-201-2-RN	70/10	dc-18	3.25 dB max	1.75	2	150T-70	Sma/F	Rear	
8310-202-FN	121/1	dc-18	5.25 dB max	1.95	1	150T-11+ 150T-110	Sma/F	Front	
8310-202-RN	121/1	dc-18	5.25 dB max	1.95	1	150T-11+ 150T-110	Sma/F	Rear	
8310-203-FN	105/1	dc-18	6.75 dB max	1.85	1	152T-15+ 152T-90	Sma/F	Front	
8310-203-RN	105/1	dc-26.5	6.75 dB max	1.85	1	152T-15+ 152T-90	Sma/F	Rear	
8310-204-FN	62/2	dc-18	3.25 dB max	1.95	1	150T-62	Sma/F	Front	
8310-204-RN	62/2	dc-18	3.25 dB max	1.95	1	150T-62	Sma/F	Rear	
8310-204-2-FN	62/2	dc-18	3.25 dB max	1.95	2	150T-62	Sma/F	Front	
8310-204-2-RN	62/2	dc-18	3.25 dB max	1.95	2	150T-62	Sma/F	Rear	
8310-352-FN	0-103/1 dB	dc-6.0 GHz	6.0 dB max	1.55	1	3408T-103	N/F	Front	193-7403-5
8310-352-RN	0-103/1 dB	dc-6.0 GHz	6.0 dB max	1.55	1	3408T-103	N/F	Rear	193-7403-5
8310-352-2-FN	0-103/1 dB	dc-6.0 GHz	6.0 dB max	1.55	2	3408T-103	N/F	Front	193-7403-6
8310-352-2-RN	0-103/1 dB	dc-6.0 GHz	6.0 dB max	1.55	2	3408T-103	N/F	Rear	193-7403-6
8310-352-3-TN	0-103/1 dB	dc-6.0 GHz	6.0 dB max	1.55	3	3408T-103	N/F	Front-Rear	193-7403-7
8310-352-4-TN	0-103/1 dB	dc-6.0 GHz	6.0 dB max	1.55	4	3408T-103	N/F	Front-Rear	193-7403-8

Table 2. 4200 Series-Solid-State, Pin Switched

Model No	Attenuator Value	Frequency Range (GHz)	Insertion Loss	SWR	No. of Channels	Attenuator Type	Connector Type	Connector Location	Drawing Number
8310-136-FN	63.75/0.25	0.8-2.5	6.0 dB max	1.6 max	1	4226T-63.75	N/F	Front	
8310-136-RN	63.75/0.25	0.8-2.5	6.0 dB max	1.6 max	1	4226T-63.75	N/F	Rear	
8310-136-2-FN	63.75/0.25	0.8-2.5	6.0 dB max	1.6 max	2	4226T-63.75	N/F	Front	
8310-136-2-RN	63.75/0.25	0.8-2.5	6.0 dB max	1.6 max	2	4226T-63.75	N/F	Rear	
8310-137-FN	63/1	0.8-3.0	4.7 dB max	1.6 max	1	4226T-63	N/F	Front	
8310-137-RN	63/1	0.8-3.0	4.7 dB max	1.6 max	1	4226T-63	N/F	Rear	
8310-137-2-FN	63/1	0.8-3.0	4.7 dB max	1.6 max	2	4226T-63	N/F	Front	
8310-137-2-RN	63/1	0.8-3.0	4.7 dB max	1.6 max	2	4226T-63	N/F	Rear	
8310-138-FN	103/1	0.8-3.0	6.0 dB max	1.6 max	1	4228T-103	N/F	Front	193-7138-5
8310-138-RN	103/1	0.8-3.0	6.0 dB max	1.6 max	1	4228T-103	N/F	Rear	193-7138-5
8310-138-2-FN	103/1	0.8-3.0	6.0 dB max	1.6 max	2	4228T-103	N/F	Front	193-7138-6
8310-138-2-RN	103/1	0.8-3.0	6.0 dB max	1.6 max	2	4228T-103	N/F	Rear	193-7138-6
8310-138-3-TN	103/1	0.8-3.0	6.0 dB max	1.6 max	3	4228T-103	N/F	Front-Rear	193-7138-7
8310-138-4-TN	103/1	0.8-3.0	6.0 dB max	1.6 max	4	4228T-103	N/F	Front-Rear	193-7138-8

3. INSTALLATION:

3-1. RACKMOUNTING: Standard 8310 Attenuator Units are shipped with four plastic feet mounted to the bottom cover, this allows the user to place the instrument on any bench or to stack the with other Weinschel instruments. The Model 8310 can also be rack mounted as a single unit using Rack Mounting Kit (P/N 193-8033-1) or two Model 8310's can be mounted together using Rack Mounting Kit (P/N 193-8033-2). Using these kits will allow the Model 8310 to be mounted in any rack or cabinet that is designed according to EIA RS-310 or MIL-STD-189.

3-2. INITIAL SETUP: The following initial setup procedures should be performed prior to operating the 8310-XXX-XN Attenuator Unit.

- a. Perform inspection paragraph 1-4 prior to connecting the 8310-XXX-XN to any power source.
- b. Check that the external power source outputs to the 8310-XXX-XN Series are in accordance with Section 2, Specifications.
- c. Install the 8310-XXX-XN Series into a cabinet or rack, if desired.
- d. Using the supplied power cord connect the 8310-XXX-XN to the external power source.
- e. Setup the IEEE-488 bus address or other Communications options for your application using 5. If using the Ethernet configure the selectable Bus Select switch to Ethernet and refer to section 5 for operating instructions.

3-3 INPUT/OUTPUT OPTIONS: The following paragraphs provide a description of the connections that can be made to the 8310-XXX-XN Attenuator Unit. Figure 2 shows the location of these connectors and switches.

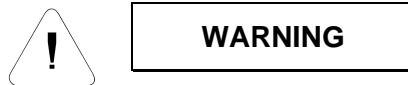

Sufficient power levels are present at the Power Input Assembly to cause personal injury. Ensure that the instrument power cord is DISCONNECTED before attempting to change fuses.

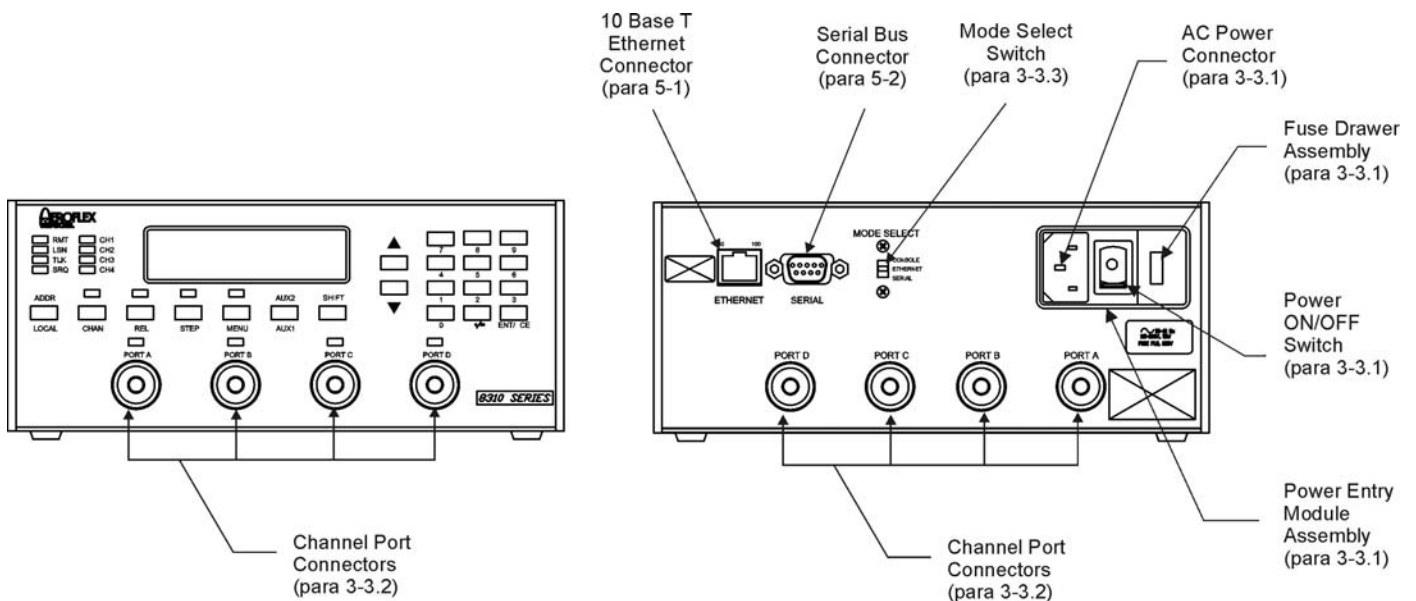

Figure 2. Rear Panel Controls & Connectors

3-3.1 POWER ENTRY MODULE ASSEMBLY: The Power Entry Module Assembly located on the rear panel contains a three-prong ac power input connector and a fuse drawer assembly (Figure 1). The **Fuse Drawer Assembly** contains the line voltage fuse (Weinschel P/N 052-1-1.5). The Model 8310-XXX-XN uses a T 1.5A, 250 Vac fuse which is 5 x 20 mm in size. Refer to paragraph 6-4 for replacement of the fuse.

The **AC Power Connector**, located on the left side of XF1 (Figure 2), is a plug-type, prong insert connector with three conductors for connection of the power cord (P/N 068-21) to the Power Supply Assembly located within the Hot-Switching High Power Attenuator Unit. This connector also grounds the chassis of the Hot-Switching High Power Attenuator Unit when the ac power cord is connected to a grounded wall outlet. If necessary, use a three prong to two prong adapter and connect the adapter's ground lead to the outlet plate retaining screw.

The **Power ON/OFF Switch** is located on the rear panel and in part of the Power Entry Module Assembly. Placing the POWER ON/OFF switch in the ON position applies power to the instrument.



When applying an RF signal to the RF INPUT connector, DO NOT exceed the maximum allowable power level specifications of the Model 8310-XX-X-XN.

3-3.2. CHANNEL PORT CONNECTORS: A typical Model 8311-XX-X-XN Series Attenuator Unit contains 12 standard D holes on the front and rear panel allowing for single or multichannel configurations. Standard Model 8311-XX-X-XN's are supplied with two PLANAR CROWN® Type N connectors that can be mounted on the front or rear panel. These connectors provide a input and output port where various types of RF signals can be applied to the devices internally mounted in the Model 8311-XX-X-XN (Connector location specified by customer when ordering). Some special configurations could contain Aeroflex / Weinschel's Model 1568 SMA Panel Adapters or other types of crowns (see accessories for other types).

NOTE

The use of the PLANAR CROWN® connectors provide the user with easy exchange of connector types, which eliminates the need for adapters and other devices that would create additional insertion loss. This type of connector also provides quick removal and replacement of defective connectors. For more information about the PLANAR CROWN® connectors contact the Sales Department at Aeroflex / Weinschel, Inc.

3-3.3. MODE SELECT SWITCH: This 3 position slide switch located on the rear panel, allows the user to select between Serial, Ethernet or Console Mode operation. Refer to paragraph 5-1 for more information about the different operational modes of the Model 8310-XXX-XN communication interface

4. FRONT PANEL CONTROLS & INDICATORS:

The following paragraphs provide setup and general guidelines for operating the Model 8310-XXX-XN Programmable Attenuator Unit and its different bus configurations.

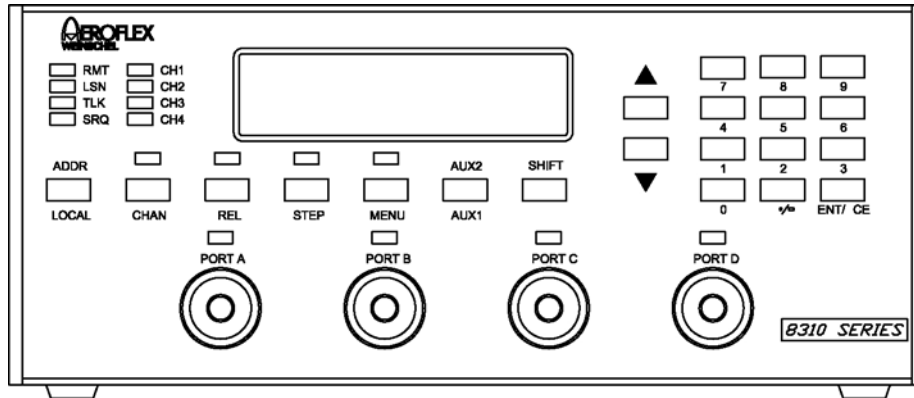

Figure 3. 8310-XXX-XN Series Front Panel

ENTRY keys: The numeric entry keys allow the user to directly enter numeric values. When using the keypad, values are not updated until the ENT (enter) key is pressed. The Minus (-) and CE (clear entry) functions may be accessed via first depressing the SHIFT key.

INCR & DECR: The INCR and DECR keys allow settings to be scrolled from their current value. Unlike the ENTRY keys, the new setting is updated immediately without the use of the ENT key.

CHAN: Allows the selection of the current channel, as indicated by the CH1-CH4 indicators. Repeated depressions of the CHAN key will select the next available channel. The main display will show the current setting of the channel.

REL: This key control allows the use of a relative mode for attenuators, as indicated by the REL mode indicator. When turned on, the currently displayed attenuation value is used as a reference value from which the attenuation may be set. In this mode, attenuation values may be positive or negative from the reference setting. When REL is turned off, the display returns to the actual attenuation setting for the channel.

STEP: This key allows the user to change the attenuation step size used by the INCR and DECR keys. When turned on, as, indicated by the STEP indicator, the current step size is displayed in the main display, and a new value may be entered using the INCR/DECR or ENTRY keys. The step size may be set to any multiple of the intrinsic step size for the currently selected channel.

MENU: Invokes the menu functions. Menu selections may be made via the INCR and DECR keys. (NOTE: menu functions are currently not implemented as of 3/8/99)

AUX1/AUX2: The function of these keys is user-programmable via remote operation. They invoke any currently defined AUX1 and AUX2 macros. Refer to the macro programming section for information on creating macro definitions.

LOCAL: This key places the 8310-XXX-XN in local operation mode, unless the key function has been overridden via an IEEE-488.2 local lockout or execution of the LOCKOUT command.

ADDR: This key displays the current IEEE-488.2 address. The address may be changed from the front-panel, however, the initial setting at power on is derived from the rear-panel address switch.

5. REMOTE OPERATION:

The following paragraphs provide setup and general guidelines for operating the Model 8310 using an external controller.

5-1. COMMUNICATIONS INTERFACE: The unit provides for control via a number of interface methods, including IEEE 488.2, RS232 serial, and 10/100 baseT Ethernet. Interface functions are split between two assemblies:

- 1). The main controller (generically referred to as the 8210A),
- 2). The Hexadeci control interface.

The 8210A is responsible for control of the RF devices, and handles GPIB and RS232 communications. The Ethernet control interface utilizes a Lantronix Xport™ Ethernet to serial device server which allows the 10/100baseT Ethernet network to communicate to the 8210A via the RS232 port.

A block diagram of the communications subsystem is shown below.

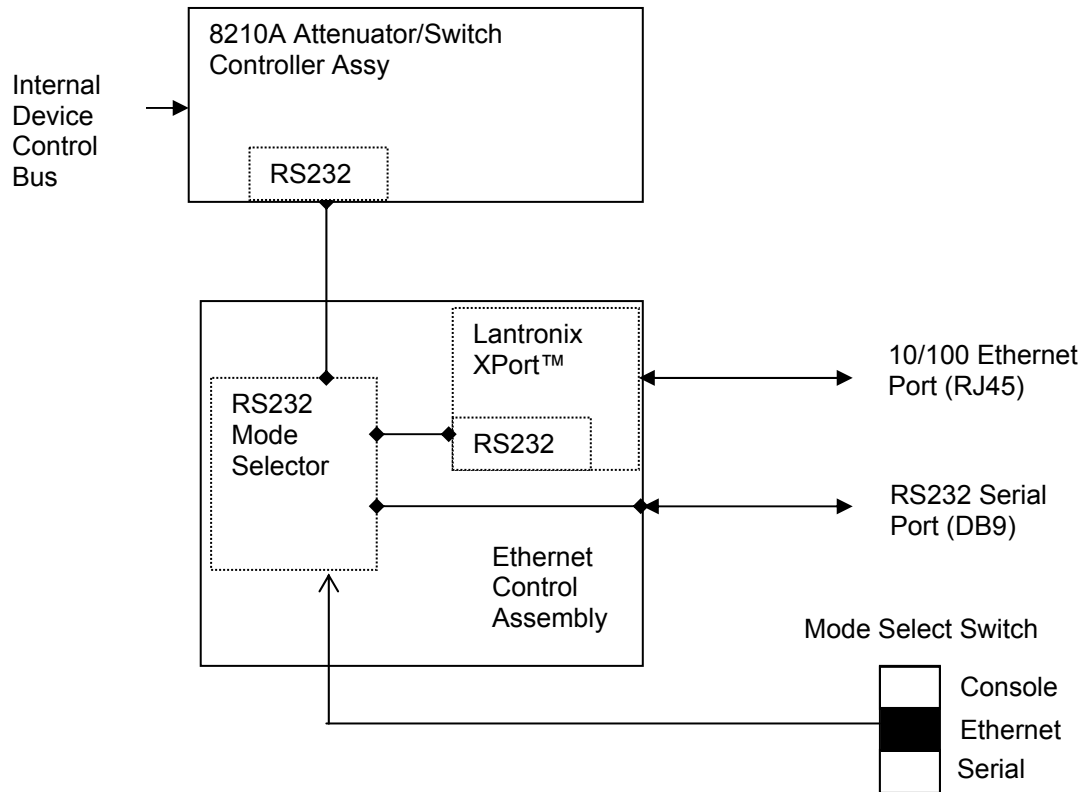

A copy of the Xport Users Guide and the Lantronix DeviceInstaller program is included on the provided CD.

For detailed information regarding the setup and operation of the XPort™ Device Server, consult the Lantronix documentation available at the Lantronix website www.lantronix.com

5-1.1 Operating Modes: The rear-panel RS232 port serves several functions, which are controlled via the 3-position Mode Select Switch.

Serial Mode: This position allows the RS232 port to be directly connected to the serial port of the 8210A, effectively bypassing the XPort's ability to control the unit via the Ethernet port. In this mode, the serial port settings are controlled via the internal DIP switch of the 8210A.

Ethernet Mode: This position internally connects the serial port of the device server to the serial port of the 8210A, allowing for network control of the unit. In this mode, the external serial port is non-functional. The serial communication settings of the device server must be set to match that of the 8210A for proper operation.

Console Mode: This position connects the RS232 port directly to the XPort device server. This mode allows the setup/configuration of the device server to be performed via the RS232 port. In this mode, serial communications are fixed at 9600 N81. For detailed information regarding operation, refer to the Xport Users Guide Chapters 5-8 (Setup Mode) and Chapter 11 (Monitor Mode).

5-1.2 Serial Port Setup: By default, the unit is shipped configured for 9600 baud, no parity, and 1 stop bit, with no handshaking required (9600N81). The rear-panel male DE-9 connector is configured as a DTE port (the same as a typical PC) with the following pinout:

Pin	Name	Dir	Description
2	RXD	←	Receive Data (in)
3	TXD	→	Transmit Data (out)
5	GND	--	System Ground

Connection to another DTE device (ie a PC) requires the use of a null-modem cable to swap pins 2 and 3.

Communication settings for the 8210A are controlled via the internal Serial/GPIB Settings DIP switch located on the board (refer to the 8210A Manual IM-288), while the XPort serial configuration is set independently and can be done using a variety of methods. Refer to the Xport Users Guide for a detailed description of the available setup mode methods and options.

NOTE

If you wish to change the serial port operation, keep in mind that the settings must match in both places in order for the XPort to communicate successfully with the 8210A when used in the Ethernet control mode.

5-1.3 Ethernet Setup: The network address of the XPort must be configured prior to use. There are several ways to assign an IP address to the Xport. A general overview is provided here. For more detailed information and links to video tutorials on performing many of these steps, refer to the information provided on the CD.

5-1.3.1 DeviceInstaller: The Lantronix DeviceInstaller is a Windows-based program that can be used to setup the Xport. Of the methods presented here, this is the simplest. However, the DeviceInstaller relies on the Xport being set for DHCP. If a static IP has been previously assigned to the Xport, there is a high probability that the DeviceInstaller will not be able to see the Xport, especially if the IP or Gateway network settings do not match that of the PC currently being used. If that is the case, you will have to use one of the other methods outlined below.

To use the DeviceInstaller utility, first install it from the product CD or click on the link below to download the latest version of DeviceInstaller.

http://ltxfaq.custhelp.com/app/answers/detail/a_id/644

- a. Insert the product CD into your CD-ROM drive.
- b. View Readme.txt located in the Lantronix Xport CD files Rev2 folder.
- c. Select the desired DeviceInstaller and run the associated setup program within the folder.
- d. Respond to the installation wizard prompts. (When prompted to select an installation type, select Typical.)

Assigning an IP Address in DeviceInstaller

- a. Click Start->Programs->Lantronix->DeviceInstaller->DeviceInstaller. If your PC has more than one network adapter, a message displays. Select an adapter and click OK.
- b. Click the Search icon and select the unit from the list of Lantronix device servers on the local network.
- c. Click the Assign IP icon.
- d. If prompted, enter the hardware address (on the product label) and click Next.
- e. Select Assign a specific IP address and click Next.
- f. Enter the IP address. The Subnet mask displays automatically based on the IP address; if desired, you may change it. On a local network, you can leave the Default gateway blank (all zeros). Click Next.
- g. Click the Assign button and wait several seconds until a confirmation message displays. Click Finish.
- h. Select the device from the main window list and select Ping from the Tools menu. The Ping Device dialog box shows the IP address of the selected unit.
- i. From the Tools menu, click the Ping button. The results display in the Status window. Click the Clear Status button to clear the window so you can ping the device again.

Note: If you do not receive "Reply" messages, make sure the unit is attached to the network properly and the IP address assigned is valid for the particular network segment you are working with. If you are not sure, check with your systems administrator.

- j. Click the Close button to close the dialog box and return to the main window.

5-1.3.2 Serial Port Login: To assign the IP address and other network settings using a serial connection:

- a. Connect a console terminal or a PC running a terminal emulation program to the rear-panel RS232 connector. The default serial port settings are 9600 baud, 8 bits, no parity, 1 stop bit, no flow control. Set the rear-panel Mode Select switch to the Console position.
- b. To enter Setup Mode, cycle the unit's power (power off and back on). After power-up, the self-test begins and the red Diagnostic LED starts blinking. You have one second to enter three lowercase 'x' characters.

Note: The easiest way to enter Setup Mode is to hold down the 'x' key at the terminal (or emulation) while powering up the unit.

- c. The display should be similar to:

```
MAC address 00204AC530DB  
Software version V6.6.0.2 (080926) XPTEXE  
Press Enter for Setup Mode
```

- d. The Xport has a built-in timeout function, and you must press the 'Enter' key within three seconds to enter the Setup Mode. If you do not, the Xport will timeout and display "?!?", after which it will continue with the boot process and you will have to repeat Step 2.
- e. Select 0 (Server Configuration) and follow the prompts until you get to IP address.
- f. Enter the new IP address, subnet mask, and gateway (if applicable).
- g. Select 9 to save and exit Setup Mode. The unit performs a power reset.

5-1.3.3 ARP and Telnet: If a serial port is unavailable, you can use the Address Resolution Protocol (ARP) method from UNIX and Windows-based systems to assign a temporary IP address.

To assign a temporary IP address:

- a. On a UNIX or Windows-based host, create an entry in the host's ARP table using the intended IP address and the hardware MAC address of the Xport, which should be available on the rear-panel of the unit. Make sure that the intended IP is reachable with the current network settings of the host. The following example uses an IP of 192.12.3.77. Substitute the desired address in it's place, and the MAC address of the Xport in place of the 00:20:4a:xx:xx:xx

```
arp -s 191.12.3.77 00:20:4a:xx:xx:xx (Unix)
arp -s 191.12.3.77 00-20-4a-xx-xx-xx (Windows)
```

- b. Open a Telnet connection to port 1. The connection fails quickly, but the unit temporarily changes its IP address to the one designated in this step.

```
telnet 191.12.3.77 1
```

- c. Open a Telnet connection to port 9999, and press Enter within three seconds to go into Setup Mode. If you wait longer than three seconds, the unit reboots and you will have to repeat Step 2.

```
telnet 191.12.3.77 9999
```

- d. Select 0 (Server Configuration) and follow the prompts until you get to IP address.
- e. Enter the new IP address, subnet mask, and gateway (if applicable).
- f. Select 9 to save and exit Setup Mode. The unit performs a power reset.

5-1.3.4 DHCP: The unit ships with a default IP address of 0.0.0.0, which automatically enables DHCP. If a DHCP server exists on the network, it provides the unit with an IP address, gateway address, and subnet mask when the unit boots up.

The DeviceInstaller software can be used to search the network for the DHCP assigned IP address and add it to the list of devices retrieved.

NOTE

This DHCP address does not appear in the unit's Setup Mode or in Web Manager. You can determine your unit's DHCP-assigned IP address in Monitor Mode. When you enter Monitor Mode from the serial port with network connection enabled and issue the NC (Network Communication) command, you see the unit's IP configuration.

5-1.3.5 AutoIP: The unit ships with a default IP address of 0.0.0.0, which automatically enables Auto IP within the unit. AutoIP is an alternative to DHCP that allows hosts to obtain an IP address automatically in smaller networks that may not have a DHCP server. A range of IP addresses (from 169.254.0.1 to 169.254.255.1) has been explicitly reserved for AutoIP-enabled devices. Do not use this range of Auto IP addresses over the Internet.

- If your unit cannot find a DHCP server, and you have not manually assigned an IP address to it, the unit automatically selects an address from the AutoIP reserved range. Then, your unit sends out a (ARP) request to other nodes on the same network to see whether the selected address is being used.
- If the selected address is not in use, then the unit uses it for local subnet communication..
- If another device is using the selected IP address, the unit selects another address from the AutoIP range and reboots. After reboot, the unit sends out another ARP request to see if the selected address is in use, and so on.

AutoIP does not replace DHCP. The unit continues to look for a DHCP server on the network. If it finds a DHCP server, the unit switches to the DHCP server-provided address and reboots.

NOTE

If a DHCP server is found, but it denies the request for an IP address, the unit does not attach to the network, but waits and retries.

AutoIP can be disabled by setting the unit's IP address to 0.0.1.0. This setting enables DHCP but disables AutoIP.

5-1.3.6 BOOTP: Similar to DHCP, but for smaller networks. Automatically assigns the IP address for a specific duration of time.

5-1.3.7 Device Server Setup: The Channel Configuration section of the Setup Mode is used to define how the serial port responds to network and serial communications when operating as a device server. See the Xport Users Guide Chapter 7 (Setup Mode: Channel Configuration) section for more details on each of these entries. Some of the important settings in this section are:

Baudrate: This is the baudrate used by the Xport to communicate to the 8210A when in device server mode. This setting must match the rate used by the 8210A, and is typically 9600.

I/F (Interface) Mode: The Interface (I/F) Mode is a bit-coded byte entered in hexadecimal notation. This setting controls the serial port settings of the device server, such as number of bits, parity, stop bits, etc. The default value for this parameter is 4C, which specifies RS-232C, 8-bit, No Parity, 1 stop bit.

Flow: Flow control sets the local handshaking method for stopping serial input/output. The default setting for this parameter is 00 (no flow control)

Port Number: The setting represents the source port number in TCP connections. It is the number that is used to establish a connection via the network interface. The default setting for this parameter is 10001. This number may have to be changed to match the user's software. Certain ports are reserved and should not be used. Refer to the section in the Xport Users Guide for a detailed list.

Compatibility note: units previously mfg'd using the Lantronix MSS-LITE were set to communicate via port 3001

Connect Mode: Connect Mode defines how the unit makes a connection, and how it reacts to incoming connections over the network. Enter Connect Mode options in hexadecimal notation. The default setting is C0, which sets the following options:

Incoming Connection - Always Accept
Response - Nothing (quiet)
Active Startup - No active startup

5-1.3.8 Example Setup Using The Serial Port:

- Set the rear-panel MODE SELECT switch to CONSOLE position.
- Open a terminal emulator. Set the PC serial port for 9600N81, no flow control. Serial port cable connections to a PC will require the use of a null-modem cable (DTE to DTE device).
- To access the Xport SETUP mode, you must enter three lowercase 'x' characters within one second after powering on the unit. The easiest way to enter Setup mode is to hold down the 'x' key, and power up the unit.
- Response should be::

MAC address 00204AC530DB
Software version V6.6.0.2 (080926) XPTEXE
Press Enter for Setup Mode

- e. Pressing the 'Enter' key should display the SETUP mode settings:

NOTE

There is a timeout function built into the SETUP mode. If you do not press the 'Enter' key within 2-3 seconds of the signon message appearing, you will need to turn off the power and start again. If the timeout occurs, you will see the characters “?!?” displayed on the screen.

***** basic parameters**

Hardware: Ethernet TPI
IP addr - 0.0.0.0/DHCP/BOOTP/AutoIP, no gateway set
DNS Server not set
DHCP device name : not set

***** Security**

SNMP is enabled
SNMP Community Name: public
Telnet Setup is enabled
TFTP Download is enabled
Port 77FEh is enabled
Web Server is enabled
Web Setup is enabled
ECHO is disabled
Enhanced Password is disabled
Port 77F0h is enabled

***** Channel 1**

Baudrate 9600, I/F Mode 4C, Flow 00
Port 10001
Connect Mode: C0
Send '+++' in Modem Mode enabled
Show IP addr after 'RING' enabled
Auto increment source port disabled
Remote IP Adr: --- none ---, Port 00000
Disconn Mode: 00
Flush Mode: 00

***** Expert**

TCP Keepalive: 45s
ARP cache timeout: 600s
CPU performance: Regular
Monitor Mode @ bootup: enabled
RS485 tx enable: active low
HTTP Port Number: 80
SMTP Port Number: 25
MTU Size: 1400
Alternate MAC: disabled
Ethernet connection type: auto-negotiate

***** E-mail**

Mail server: 0.0.0.0
Unit :
Domain :
Recipient 1:
Recipient 2:

- Trigger 1
 Serial trigger input: disabled
 Channel: 1
 Match: 00,00
 Trigger input1: X
 Trigger input2: X
 Trigger input3: X
 Message :
 Priority: L
 Min. notification interval: 1 s
 Re-notification interval : 0 s

- Trigger 2
 Serial trigger input: disabled
 Channel: 1
 Match: 00,00
 Trigger input1: X
 Trigger input2: X
 Trigger input3: X
 Message :
 Priority: L
 Min. notification interval: 1 s
 Re-notification interval : 0 s

- Trigger 3
 Serial trigger input: disabled
 Channel: 1
 Match: 00,00
 Trigger input1: X
 Trigger input2: X
 Trigger input3: X
 Message :
 Priority: L
 Min. notification interval: 1 s
 Re-notification interval : 0 s

Change Setup:

0 Server
 1 Channel 1
 3 E-mail
 5 Expert
 6 Security
 7 Defaults
 8 Exit without save
 9 Save and exit Your choice ?

To change the IP settings of the device server, Select '0' (Server)

At the prompts, enter the desired settings.

For example, to set an IP = 10.100.103.1, netmask = 255.255.255.0, with no gateway:

IP Address : (000) 10.(000) 100.(000) 103.(000) 1
 Set Gateway IP Address (N) ?
 Netmask: Number of Bits for Host Part (0=default) (0) 8
 Set DNS Server IP addr (N) ?
 Change telnet config password (N) ?

Change Setup:

- 0 Server**
- 1 Channel 1**
- 3 E-mail**
- 5 Expert**
- 6 Security**
- 7 Defaults**
- 8 Exit without save**
- 9 Save and exit Your choice ?**

Parameters stored ...

Turn off power. To verify the settings you can use the Xport Monitor Mode. To enter Monitor mode, hold down the 'z' key while powering up the unit. After a few seconds, you should see

***** NodeSet 2.0 *****

0>zzzzzzzzzzzzzz

9>

Enter 'NC' in uppercase letters, which is the Network Connection command, whose function is to display the unit's IP configuration

9>NC

IP 010.100.103.049 GW 010.100.103.254 Mask 255.255.255.000 NS 010.100.103.173

0>

NOTE

The parameters shown above were obtained with the Xport set for DHCP mode (IP=0.0.0.0)

Enter 'QU' to quit and exit diagnostics monitor mode.

0> QU

Place the MODE SELECT switch to the ETHERNET position.

To verify network connectivity, you can open a command prompt window on the PC (Start menu | Run... | CMD) and ping the assigned IP address.

C:\WINDOWS>ping 10.100.103.49

Pinging 10.100.103.49 with 32 bytes of data:

Reply from 10.100.103.49: bytes=32 time=7ms TTL=64

Reply from 10.100.103.49: bytes=32 time<1ms TTL=64

Reply from 10.100.103.49: bytes=32 time<1ms TTL=64

Reply from 10.100.103.49: bytes=32 time<1ms TTL=64

Ping statistics for 10.100.103.49:

Packets: Sent = 4, Received = 4, Lost = 0 (0% loss),

Approximate round trip times in milli-seconds:

Minimum = 0ms, Maximum = 7ms, Average = 1ms

You should now be able to communicate with the device. To send commands, you can use the Windows Telnet application to open a connection to Port 10001 (the default serial device tunnel port)

```
C:\WINDOWS>telnet 10.100.103.49 10001
```

Characters that you type in the telnet window will be sent to the device. For example, typing “*IDN?” Should get a response similar to:

```
Weinschel, 8310, 001, V2.98
```

NOTE

By default, the controller does not echo received characters, so the telnet client must be set for 'local echo' in order to see the characters that you type. Optionally, you can send the command “ECHO 1” to set the controller to echo received characters.

5-2. SERIAL OPERATION: The serial interface (RS232/RS422) provides a means of remotely programming the 6853 via external computer. The 6853 provides for user-selectable communications parameters via a DIP switch (SW1), including baud rate, data format, and handshaking method. LED indicators are provided for transmit (TX) and receive (RX) activity. Selection between RS232/RS422 mode is controlled via an internal 4 position DIP switch SW2, which also provides for user-selectable 120 ohm terminations for the RS422 receiver lines. The RS422 mode transceivers are electrically compatible with RS485.

SW2	RS232	RS422 RS485	Description
1	OFF	User Select	CTS Termination On = Termination Off = No Termination
2	OFF	User Select	RXD Termination On = Termination Off = No Termination
3	OFF	ON	RI/RTS Select
4	ON	OFF	Serial Mode On = RS232 Off = RS422

The data format includes a start bit, eight data bits, and one stop bit (N81). The Baud Rate may be set to 2400, 9600, 19200, or 34800. Parity selections include settings for None, Even, or Odd parity. Handshaking may be enabled, if desired, and the method may be set to either hardware (RTS/CTS) or software (XON/XOFF). For interactive terminal use, echoing may be enabled, in which the 8210A will echo all characters received back to the terminal.

All data and commands are encoded using the ASCII character set. The syntax for commands is the same as for GPIB operation, and uses the syntax structure defined by IEEE 488.2, with the exception of the command termination rules. Commands sent to the 6853 may be terminated with either an ASCII CR (0x0D) or ASCII LF (0x0A) character. By default, all responses from the 6853 are terminated in an ASCII CR/LF sequence (0x0D followed by 0x0A).

Software handshaking uses the XON/XOFF scheme in which an ASCII DC3 (0x13) character is transmitted by the receiver to indicate that data transmission should be halted (XOFF), and an ASCII DC1 (0x11) character is transmitted to indicate that data transmission may continue (XON). Hardware handshaking utilizes the RTS and CTS lines. When the RTS output signal is asserted true, the unit is ready for data. This signal should be connected to the external computer's CTS input signal, so that when the receiver is ready, the transmitter may send data. When the unit is not ready for data, it unasserts the RTS signal, halting data transmission. Likewise, the unit monitors the CTS input signal during data transmission, halting transmission if the external computer unasserts its RTS signal. In addition, the 6853 unasserts the RTS signal while command execution is in progress.

For those systems incorporating local front panel controls, the serial port can lockout local users, providing a Remote/Local function similar to that of GPIB operation.

5-2.1. RS-232 Operation: The RS-232 Serial port is a 9-pin connector that is compatible with the pin-out of the serial port on a PC. It allows the use of a null-modem style cable. The pin-out for the connector is show below. For clarity, the signal names and directions are relative to the 6631.

<u>Pin</u>	<u>Signal Name</u>	<u>Description</u>	<u>Direction</u>
1	DCD	unused	---
2	RxD	Receive data	input
3	TxD	Transmit data	output
4	DTR	Signals DTE is on-line	output
5	GND	Ground	---
6	DSR	unused	---
7	RTS	Signals DTE is ready	output
8	CTS	Signals DCE is ready	input
9	RI	unused	---

The DTR signal is asserted when power is on, indicating that the unit is ready.

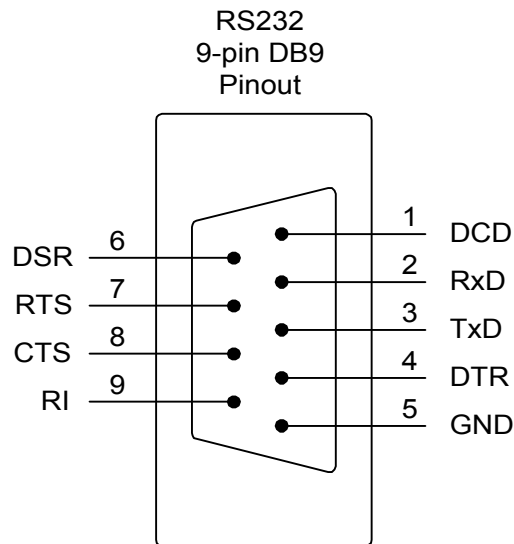

Null Modem Cable

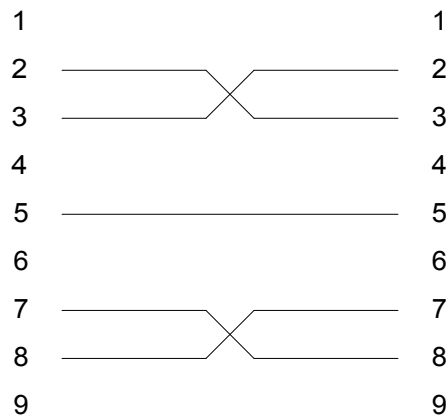

5-3 Status Reporting

The 6853 implements the 488.2 Status Reporting Structure, which utilizes the IEEE488.1 status byte with additional data structures and rules. The Status Byte Register can be read with either a serial poll (IEEE-488 operation only) or the *STB? Common query command. The Service Request Enable Register (SRE) allows the user to select which bits in the Status Byte Register may cause service requests. A bit value of one indicates that the corresponding event is enabled, while a bit value of zero disables an event. The Service Request Enable Register may be accessed with the *SRE and *SRE? Common commands. The Status Byte Register may be cleared with the *CLS common command, with the exception of the MAV bit, which is controlled by the operation of the Output Queue. The SRE Register is set to 0 at power-on, disabling all events.

Status Byte Register/ Service Request Enable Register Formats

D7	D6	D5	D4	D3	D2	D1	D0
	RQS	ESB	MAV		EEQ		

<u>Bit</u>	<u>Mnemonic</u>	<u>Description</u>
6	RQS	Request Service: This bit, if set, indicates that the device is asserting the SRQ signal.
5	ESB	Event Status Bit: This bit is true when an enabled event in the Event Status Register is true.
4	MAV	Message Available: This bit is true when there is valid data available in the output queue.
2	EEQ	Error/Event Queue: This bit is true when there is Error/Event data available in the Error/Event queue.

The Standard Event Status Register is used to report various IEEE 488.2-defined events. The register contents may be accessed with the *ESR? Command. An Event Status Enable Register allows the user to select which bits in the ESR that will be reflected in the ESB summary message bit of the Status Byte Register. The Event Status Enable Register may be accessed with the *ESE and *ESE? Common commands. The Event Status Register is cleared by an *ESR? Query or *CLS common command. The ESE Register is set to 0 at power-on, disabling all events.

Standard Event Status Register/ Standard Event Status Enable Register Formats

D7	D6	D5	D4	D3	D2	D1	D0
ON	URQ	CME	EXE	DDE	QYE	RQC	OPC

<u>Bit</u>	<u>Mnemonic</u>	<u>Description</u>
7	PON	Power On: This bit indicates that the device has powered-on
6	URQ	User Request: This event bit indicates that a local control is causing a User Request
5	CME	Command Error: The parser has detected a syntax error in the current command.
4	EXE	Execution Error: The command could not be properly executed due to an illegal input range or other inconsistent data.
3	DDE	Device Dependent Error: A command could not properly complete due to some device specific error
2	QYE	Query Error: This bit indicates that either an attempt has been made to read data when there was none present, or that data in the Output Queue has been lost
1	RQC	Request Control: The device is requesting control (not implemented)
0	OPC	Operation Complete: This bit is generated in response to an *OPC command. It indicates that the ITS 2000 has completed all pending operations.

The Status Reporting Registers may be used for serial communications, with certain limitations. The Status Byte Register can only be read via the *STB? Query command, as the □exad port does not provide for a serial poll operation. Also, as data in the Output Queue is sent automatically during serial operation, the MAV message available bit in the STB serves no purpose.

5-4. GENERAL SYNTAX STRUCTURE: The following paragraphs outline the general syntax and command structure for the Model 6631. This structure is common to all bus flavors of the Model 6631.

NOTE

In the descriptions that follow, the term whitespace is used to define a sequence of one or more combinations of ASCII Space (20h), Carriage return (0Dh), or Tab (09h) characters.

5-4.1 SYNTAX OF QUERIES: A query message unit is made up of a query header ending in an ASCII question mark character '?' (3FH), followed by optional whitespace, and ended by a program message terminator. To form a multiple query, separate the individual program message units with a semicolon.

Examples : "ATTN?"
"ASSIGN?"

Multiple Query Commands:

"ATTN?; ASSIGN?"

5-4.2 SYNTAX OF COMMANDS: A command message unit is made up of a command header, optionally followed by an argument and units, and ended by a program message terminator. If multiple commands are made on the same program line, separate the individual command messages with a semicolon.

Arguments – The 6853 supports a variety of argument types that can be used in program commands. These types are:

- Character Program Data
- Integer Numeric Program Data
- Real Numeric Program Data

Each data type has its own rules of syntax. The following paragraphs provide the syntax rules for each of the argument types listed above.

Character Program Data-This data type is comprised of the set of printable ASCII characters (excluding those used as delimiters). Character program data represents alpha or alphanumeric strings. The use of alpha characters is case-insensitive. If the first character of the string is not an alpha character, then the string must be delimited with either the ASCII single-quote (') or double-quote (") character in order to distinguish the string from a numeric data type.

Examples: ATTN1
ON
"150T"

Integer Numeric Program Data-This data type is used to represent integer, binary, or □exadecimal numeric information, all of which may be used interchangeably. Integer data is comprised of the numeric digits '0'-'9', binary data is comprised of the digits '0' and '1' preceded by the characters '#B', and □exadecimal data is comprised of the digits '0'-'9', and the letters 'A'-'F', preceded by the characters '#H' or the C language style prefix '0x'.

Examples: 123 (integer)
#H55 (hex)
0xAA (hex)
#B1010 (binary)

Real Numeric Program Data-This data type includes decimal numbers containing a sign, decimal point, and/or an exponent. The format is as follows: [sign]digits[.[digits]][E[sign]digits]

Examples: 2
 2.5
 -35.25E+2

In the command descriptions that follow, argument types are also described using the following additional conventions to indicate the relative size of the parameter:

byte	- used to indicate an 8-bit unsigned integer
word	- used to indicate a 16-bit unsigned integer
int8	- 8-bit integer
int16	- 16-bit integer
int32	- 32-bit integer
string	- character data, including the max number of characters allowable. (i.e., string8 has a max of 8 chars)

5-4.3 OUTPUT DATA FORMAT: Output data from the Model 6853 consists of a series of ASCII digits and message strings, terminated with an ASCII Line-Feed character (0AH), in response to a program message that contains one or more query commands. In the case of multiple query commands in the same program message, the data resulting from each of the individual message units will be separated by an ASCII comma (2CH) character.

5-4.4 NOTATIONAL CONVENTION.

- [] Brackets indicate optional arguments or parameters.
- { } One and only one of the enclosed entries must be selected unless the field is also surrounded by brackets, in which case it is optional.
- ... Ellipses indicate that the preceding argument or parameter may be repeated.
- [,...] The preceding item may be repeated, but each repetition must be separated by a comma.

5-5. COMMON COMMANDS

*CLS	Function: Clears the Status Byte and Event Status Registers. Syntax: *CLS Argument(s): none Remarks: This function is used to clear the Status Byte and the Event Status Registers. Return Value: none Example(s): *CLS
*ESE	Function: Sets the Event Status Enable Register. Syntax: *ESE <i>mask</i> Argument(s): <i>mask</i> integer bitmask Remarks: This function is used to set the Event Status Enable Register to the value specified by <i>mask</i> . Return Value: none Example(s): *ESE 255
*ESE?	Function: Reads the Event Status Enable Register. Syntax: *ESE? Argument(s): none Remarks: This function is used to read the Event Status Enable Register. Return Value: <i>mask</i> integer register mask Example(s): *ESE? returns the following '255'
*ESR?	Function: Reads the Event Status Register Syntax: *ESR? Argument(s): none Remarks: This function is used to read the Event Status Register. Reading the register clears it. Return Value: <i>reg</i> integer register Example(s): *ESR? returns the following '128'
*SRE	Function: Sets the Status Byte Enable Register Syntax: *SRE <i>mask</i> Argument(s): <i>mask</i> integer bitmask Remarks: This function is used to set the Status Byte Enable Register to the value specified by <i>mask</i> . Return Value: none Example(s): *SRE 255
*SRE?	Function: Reads the Status Byte Enable Register. Syntax: *SRE? Argument(s): none Remarks: This function is used to read the Status Byte Enable Register. Return Value: <i>mask</i> integer register mask Example(s): *SRE? returns the following '255'
*STB?	Function: Reads the Status Byte Register. Syntax: *STB? Argument(s): none Remarks: This function is used to read the Status Byte Register. Return Value: <i>reg</i> integer register Example(s): *STB? returns the following '96'
*IDN?	Function: Reads the system identification information. Syntax: *IDN? Argument(s): none Remarks: This function is used to read the system identification information, which is a string consisting of the following data: manufacturer, model, serial number, and firmware version. Return Value: <i>mfg</i> integer count of devices Example(s): *IDN? returns the following 'Weinschel,8311 Series, 123, 1.00A'

*RST	Function: Performs a device reset. Syntax: *RST Argument(s): none Remarks: This function is used to reset the device. Return Value: none Example(s): *RST
*OPC	Function: Operation complete service request. Syntax: *OPC Argument(s): none Remarks: This function generates the Operation Complete message (OPC) in the Standard Event Status Register when all pending device operations have finished. Return Value: none Example(s): *OPC
*OPC?	Function: Operation complete query Syntax: *OPC? Argument(s): none Remarks: This function loads a '1' into the output queue when the Program Message Unit is executed. Its primary use is to provide an indication of command completion by including the command as the last one in a series of commands. Return Value: 1 integer command completed Example(s): SAVE ASSIGN; *OPC? returns a '1' when the SAVE ASSIGN command completes.
*WAI	Function: Wait To Continue Syntax: *WAI Argument(s): none Remarks: This function prevents the 8311 Series from executing any further commands or queries until there are no pending operations. The 8311 Series executes all commands sequentially, and does not allow overlapping commands. Return Value: none Example(s): *WAI

5-6. GENERAL COMMANDS:

CHAN	Function: Selects the currently active channel Syntax: CHAN <i>chnum</i> Argument(s): <i>chnum</i> integer channel number Remarks: This function is used to select the currently active channel. Return Value: none Example(s): CHAN 1
CHAN?	Function: Reads the current channel number Syntax: CHAN? Argument(s): none Remarks: This function is used to read the currently active channel number. Return Value: <i>chnum</i> integer current channel number Example(s): CHAN? Returns '1'
ATTN	Function: Set attenuation Syntax: ATTN <i>atten</i> Argument(s): <i>atten</i> real desired value, in dB Remarks: This function sets the attenuation of the currently selected channel to <i>atten</i> . Return Value: none Example(s): ATTN 63 ATTN 12.25 ATTN 45.0
ATTN?	Function: Read attenuation Syntax: ATTN? Argument(s): none Remarks: This function reads the attenuation of the currently selected channel. Return Value: <i>atten</i> real attenuation value, in dB Example(s): ATTN? returns '63.00'
REL	Function: Sets relative display mode for the current channel Syntax: REL <i>mode</i> Argument(s): <i>mode</i> integer relative mode on/off Remarks: This function is used to set the relative display mode of operation for the current channel. A value of 0 for the parameter <i>mode</i> will turn relative mode off, while a value of 1 will turn relative mode on. Return Value: none Example(s): REL 1
REF	Function: Sets reference Syntax: REF Argument(s): none Remarks: This function sets the reference value for the active channel to the current attenuation setting. This command is used for the REL and RELATTN functions. Return Value: none Example(s): REF; REL 1 sets the reference, and turns on relative mode
REF?	Function: Read reference setting Syntax: REF? Argument(s): none Remarks: This function reads the reference setting of the currently selected channel. Return Value: <i>refatten</i> real reference attenuation value, in dB Example(s): REF? returns '30.00'

RELATTN	<p>Function: Sets attenuation relative to the reference setting</p> <p>Syntax: RELATTN <i>atten</i></p> <p>Argument(s): <i>atten</i> real desired value, in dB</p> <p>Remarks: This function sets the attenuation of the currently selected channel to <i>atten</i>, relative to the reference value set when the REL command was executed.</p> <p>Return Value: none</p> <p>Example(s): RELATTN 10 increases the attenuation setting 10dB from the reference setting RELATTN -10 decreases the attenuation setting by 10dB from the reference setting 15.</p>
RELATTN?	<p>Function: Read relative attenuation of the current channel</p> <p>Syntax: RELATTN?</p> <p>Argument(s): none</p> <p>Remarks: This function reads the relative attenuation of the currently selected channel.</p> <p>Return Value: <i>relatten</i> real relative attenuation value, in dB</p> <p>Example(s): RELATTN? Returns '-10.00'</p>
STEPSIZE	<p>Function: Sets attenuation stepsize for the current channel</p> <p>Syntax: STEPSIZE <i>atten</i></p> <p>Argument(s): <i>atten</i> real desired stepsize value, in dB</p> <p>Remarks: This function sets the attenuation stepsize for the INCR and DECR commands for the current channel to <i>atten</i>. The default value of the attenuator's stepsize is the intrinsic resolution of the attenuator, i.e., a 127dB/1dB step attenuator has a default stepsize of 1dB.</p> <p>Return Value: none</p> <p>Example(s): STEPSIZE 10 changes the stepsize to 10dB</p>
STEPSIZE?	<p>Function: Read attenuation stepsize</p> <p>Syntax: STEPSIZE?</p> <p>Argument(s): none</p> <p>Remarks: This function reads the attenuation stepsize of the current channel.</p> <p>Return Value: <i>atten</i> real attenuation stepsize value, in dB</p> <p>Example(s): STEPSIZE? Returns '10.00'</p>
INCR	<p>Function: Increments attenuation</p> <p>Syntax: INCR</p> <p>Argument(s): none</p> <p>Remarks: This function increments the attenuation setting of the current channel by the value of the attenuator's programmed stepsize (see STEPSIZE command).</p> <p>Return Value: none</p> <p>Example(s): INCR</p>
DECR	<p>Function: Decrements attenuation</p> <p>Syntax: INCR</p> <p>Argument(s): none</p> <p>Remarks: This function decrements the attenuation setting of the current channel by the value of the attenuator's programmed stepsize (see STEPSIZE command).</p> <p>Return Value: none</p> <p>Example(s): DECR</p>

6. MAINTENANCE:

The following paragraphs provide general inspection and maintenance guide-lines for the Model 8310-XXX-XN Attenuator Unit.

6-1. INSPECTION: Perform a visual inspection in conjunction with the maintenance activities schedule when a malfunction is suspected, or whenever an assembly is removed or replaced.

6-2. PREVENTIVE MAINTENANCE: While the 8310 requires very little preventive maintenance, it should not be subjected to physical abuse, severe mechanical shock, high humidity, or operating temperatures outside the specification range. The instrument should be kept free of excessive dirt and dust, since these can interfere with connector functions and with normal heat dissipation. For cleaning instructions refer to paragraph 6-3 (special cleaning instructions). The following paragraphs provide the preventive maintenance that is to be performed on the Unit.

Care should be taken to prevent strain on the interconnecting cables, since damage here may not always be apparent. Occasionally check the external cables and connectors for signs of cracked insulation and/or bent or worn pins. Tests show that connectors must be clean for accuracy and stability. This requires an inspection and cleaning of each connector immediately before use. For connector cleaning instructions, refer to paragraph 6-3. When cleaning precautions are observed regularly, connectors can maintain their stability for over several thousand connection cycles. Refer to Appendix A for more information about cables and connectors.

6-3. SPECIAL CLEANING INSTRUCTIONS: The cleaning procedures for 8310 are divided into five general groups: microwave coaxial cable assemblies, circuit card and modules; machined surfaces and hardware, chassis cleaning, and connector cleaning.

6-3.1. MICROWAVE COAXIAL CABLE ASSEMBLIES: Appendix A (located at the end of this manual) provides all the necessary procedures for care, cleaning, and handling of microwave coaxial cable assemblies.

6-3.2 CIRCUIT CARDS AND MODULES: A protective coating is applied to circuit cards for protection from moisture, arcing, short-circuiting, and abrasion. To remove light dirt from circuit cards and modules proceed as follows:



CAUTION

- DO NOT use a nylon bristle brush in the solvent as the bristles may dissolve and cause damage to the circuit card or component.
 - DO NOT use ultrasonic cleaning on parts or assemblies containing electrical or electronic components.
 - DO NOT bend pins of electrical connectors when using fiber-bristle brush.
- a. Briskly brush isopropyl alcohol onto area to be cleaned with fiber-bristle brush.
 - b. Carefully remove residue with a clean lint-free cloth and repeat step "a" as a rinse.



WARNING

Compressed air used for cleaning and/or drying can create airborne particles that may enter the eye. Goggles/ faceshields should be worn. DO NOT direct air stream towards self or other personnel. Pressure should be restricted to a maximum 15 psi to avoid personal injury.

- c. When parts are thoroughly clean, dry parts using 5 psi of clean moisture free compressed air or preferably dry nitrogen (pressurized spray will work well).

6-3.3 MACHINED SURFACES AND HARDWARE: To remove light dirt and dust from mechanical parts such as castings, covers and other hardware proceed as follows:

**WARNING**

Compressed air used for cleaning and/or drying can create airborne particles that may enter the eye. Goggles/ face-shields should be worn. DO NOT direct air stream towards self or other personnel. Pressure should be restricted to a maximum 15 psi to avoid personal injury.

**CAUTION**

- Under no circumstances use a wire brush, steel wool, or abrasive compound. Using these items will cause extensive damage to the instrument's surface.
 - DO NOT use a nylon bristle brush in solvent as the bristles may dissolve and cause damage to the circuit card or component.
- a. Use 5 psi of clean, moisture-free compressed air or preferably dry nitrogen to blow loose dirt and dust from surface of item.
 - b. Briskly brush isopropyl alcohol onto area to be cleaned with a fiber-bristle brush.
 - c. Remove residue with lint-free cloth and repeat step "b" as a rinse.
 - d. When parts are thoroughly clean, dry parts using 5 psi of clean, moisture-free compressed air or preferably dry nitrogen.
 - e. Clean smaller mechanical parts or hardware by dipping into a container of isopropyl alcohol. Remove dirt by brushing with fiber-bristle brush after parts have been immersed for several hours.
 - f. Remove parts from isopropyl alcohol and rinse by immersing into a different container of isopropyl alcohol.
 - g. When parts are thoroughly cleaned, dry parts using 5 psi of clean, moisture-free compressed air or preferably dry nitrogen.

6-3.4 CHASSIS CLEANING: Clean chassis using a lint-free cloth moistened with water and mild detergent. For harder to clean areas, such as inside corners of chassis, use a vacuum cleaner.

6-3.5 CONNECTOR CLEANING: Where small amounts of rust, corrosion, and/or oxide deposits are present on connectors, clean externally with a soft-bristle brush, aluminum wool, or internally with an acid brush; then wash with a non-corrosive solvent. Exercise care to ensure no metal filing or residue remains inside the connector and the connector is thoroughly dry. Where rust, corrosion, and/or oxide deposits are present in large quantities, replace the connector.

6-4. LINE VOLTAGE FUSE REPLACEMENT: The following steps provide procedures to replace the line voltage Fuse Assembly. This unit accepts a F1.5A, 250 Vac fuse for 115 Vac.

**WARNING**

Sufficient power levels are present at the Power Input Assembly to cause personal injury. Ensure that the instrument power cord is DISCONNECTED before attempting to change fuses.

**CAUTION**

DO NOT connect or apply power to this instrument until the Power Entry Module Assembly has been adjusted to the operational line voltage.

- a. Disconnect the power cord from the Power Entry Module Assembly.
- b. Use a small screwdriver to carefully open the Fuse Drawer.
- c. Slide out Fuse Drawer located in the center of the Power Entry Module Assembly.
- d. Remove defective fuse and replace with the correct fuse (Refer to applicable parts list for fuse part number).
- e. Snap the Fuse Drawer shut and re-connect ac power cord.

7. REPLACEABLE PARTS LIST:

This section lists and describes the parts located in the Model 8310-XXX-XN Programmable Attenuator Unit (P/N 193-9000-206). The Replaceable Parts Lists (RPL) is intended for use in identifying, locating, and requisitioning assemblies and components for the Model 8310-XXX-XN.

7-1 UNDERSTANDING REFERENCE DESIGNATORS: All assemblies and electrical parts are identified by standard reference designators (resistors R1, for example). Reference designators are used in parts lists and on parts identification drawings. The title of a parts list or drawing contains the reference designator or the assembly or subassembly to which it applies. The designators in the parts list, as a prefix, but omitted from the list to make it easier to locate a specific part. To complete a reference designator in a parts list, precede the designator for the specific part (DS1, for example) with the designator in the title (A6, for example) to form a complete reference designator for the part (in this case, A6DS1).

7-2 ORDERING INFORMATION: When ordering parts from Aeroflex / Weinschel, please include the following information:

- Aeroflex / Weinschel part number.
- Description of the component or part.
- Model and serial number of the instrument.
- Assembly number and assembly revision (if any) from the assembly (this information is on the component side of the PCB).

7-3 DRAWING NUMBER: The Aeroflex / Weinschel part number consists of a basic number with a dash number. The basic number should cross reference to a drawing number for most of the items. For those items that do not have a drawing number, the manufacturers part number is provided.

7-4 REPLACEABLE PARTS LIST (RPL): This RPL contains a breakdown of the instrument into its major assemblies and detailed parts. The following paragraphs describe the contents of each column of the RPL.

7-4.1 REFERENCE DESIGNATOR: This column contains reference designations arranged in alphanumeric sequence. The letters A thru Z have precedence, followed by numerals 0 thru 9. In addition to the reference designators that are listed, some mechanical parts are also listed. These items lack reference designators and are included because they are considered subject to wear and/or breakage, or because they are custom (non-standard) hardware or parts that might become lost or damaged. This column contains the word N/A for those items or parts not having a reference designator.

7-4.2 DESCRIPTION: This column contains the nomenclature located in the title block of the engineering drawing by the designing activity. The noun name is listed first, followed by modifiers and descriptive information to completely identify the part or assembly.

7-4.3 PART NUMBER: This column contains the Aeroflex / Weinschel part number assigned to an assembly, sub-assembly, or detailed part. This also includes Aeroflex / Weinschel numbers for specification control, source control, and altered items drawings.

7-4.4 VENDOR PART NO.: This column contains manufacturers part numbers for those parts Aeroflex / Weinschel purchases as off the shelf items and assigns Weinschel part numbers for internal control only. These parts may be ordered through the manufacturer or through Aeroflex / Weinschel by the Aeroflex / Weinschel part number.

7-4.5 CAGE CODE: This column provides the Commercial and Government Entity (CAGE) code on the same line as the applicable part number. Codes, names, and addresses of vendors with an assigned CAGE are listed in Cataloging Handbook H4-1 and H4-2. Vendors that have not been assigned CAGE codes by the government are identified by the word NONE in this column. The names and addresses of these vendors can be obtained from Weinschel. Part numbers that have no CAGE numbers listed are manufactured or altered by Aeroflex / Weinschel.

7-4.6 ASSEMBLY AND COMPONENT LOCATION: The assembly/component location and schematic diagrams for the different 8310-XXX-XN series models are located in rear of this manual by the drawing number. Drawing find numbers have also been included to help locate components or hardware.

Model 8310-1-FN / -RN, Attenuator Unit Assembly Replaceable Parts List (P/N 193-7001-4, Rev. A):

Find No.	Part Number	Description	Quantity Used	Reference Designator	CAGE Code	Vendor Part Number
1	193-8034-3	ASSY, BASE UNIT, W/ETHERNET (+15V)	1	NA		
2	193-9207	MOUNTING PLATE	1	NA		
3	3250T-63	ATTEN PRGM 63dB/1dB STEPS 75 OHMS	1	AT1		
4	193-8122	ASSY, CABLE, CONTROL	1	W7		
6	068-56-11/0	COAXIAL CABLE ASSY, BNC MALE TO FEMALE BULKHEAD, 75 OHM	1	W10	93459	B068-56-11/0
7	068-56-15/0	COAXIAL CABLE ASSY, BNC MALE TO FEMALE BULKHEAD, 75 OHM	1	W11	93459	B068-56/15/0
8	090-301	* LABEL STD 1.5 X .75 IN	1	NA		
9	074-761	HOLE PLUG 1/2 HOLE NYLON BLACK	6	NA	83330	3092
10	193-9213	SPACER, LOCKING	2	NA		
13	074-921	FEET NON-SKID	4	NA	4963 4963 24803	SJ-5008 BLACK SJ-5008SP KFT12-BLK
14	NAS662C2R4	SCR FLAT HD 2-56 X 1/4 LG 100	2	NA		
15	NAS1635-04LR4	SCR PAN HD SELFLOCK 4-40 X 1/4	6	NA		
18	193-8135	WIRING DIAGRAM, ATTEN UNIT MODEL 8310, +15V W/ETHERNET	0	NA		
19	089-4052	ICD, ATTEN UNIT MODEL 8310 (75 OHM) W/ETHERNET (+15V)	0	NA		
20	IM493	O & S MANUAL, MODEL 8310 W/ETHERNET	1	NA		

Refer to Aeroflex / Weinschel Drawing 193-7001-4, Rev. A for parts location.

Model 8310-1-2-FN / -RN, Attenuator Unit Assembly Replaceable Parts List (P/N 193-7002-5, Rev. A):

Find No.	Part Number	Description	Quantity Used	Reference Designator	CAGE Code	Vendor Part Number
1	193-8034-3	ASSY, BASE UNIT, W/ETHERNET (+15V)	1	NA		
2	193-8039	MOUNTING PLATE	1	NA		
3	3250T-63	ATTEN PRGM 63 dB/1dB STEPS 75 OHMS	2	AT1, AT2		
4	193-8122	ASSY, CABLE, CONTROL	1	W7		
6	068-56-11/0	COAXIAL CABLE ASSY, BNC MALE TO FEMALE BULKHEAD, 75 OHM	2	W10, W12	93459	B068-56-11/0
7	068-56-15/0	COAXIAL CABLE ASSY, BNC MALE TO FEMALE BULKHEAD, 75 OHM	2	W11,W13	93459	B068-56/15/0
8	090-301	* LABEL STD, 1.5 X .75 IN	1	NA		
9	074-761	HOLE PLUG 1/2 HOLE NYLON BLACK	4	NA	83330	3092
10	193-9213	SPACER, LOCKING	4	NA		
12	NAS1635-04LR4	SCR PAN HD SELFLOCK 4-40 X 1/4	6	NA		
13	074-921	FEET NON-SKID	4	NA	4963 4963 24803	SJ-5008 BLACK SJ-5008SP KFT12-BLK
14	NAS662C2R4	SCR FLAT HD 2-56 X 1/4 LG 100	4	NA		
18	193-8135	WIRING DIAGRAM, ATTEN UNIT MODEL 8310, +15V W/ETHERNET	0	NA		
19	089-4052	ICD, ATTEN UNIT MODEL 8310 (75 OHM) W/ETHERNET (+15V)	0	NA		
20	IM493	O & S MANUAL, MODEL 8310 W/ETHERNET	1	NA		

Refer to Aeroflex / Weinschel Drawing 193-7001-5, Rev. A for parts location.

Model 8310-1-3-TN Attenuator Unit Assembly Replaceable Parts List (P/N 193-7001-6, Rev. A):

Find No.	Part Number	Description	Quantity Used	Reference Designator	CAGE Code	Vendor Part Number
1	193-8034-3	ASSY, BASE UNIT, W/ETHERNET (+15V)	1	NA		
2	193-9207	MOUNTING PLATE	1	NA		
3	3250T-63	ATTEN PRGM, 63dB/1dB STEPS 75 OHMS	3	AT1 - AT3		
4	193-8122	ASSY, CABLE, CONTROL	1	W7		
6	068-56-11/0	COAXIAL CABLE ASSY, BNC MALE TO FEMALE BULKHEAD, 75 OHM	6	W10 - W15	93459	B068-56-11/0
8	090-301	* LABEL STD, 1.5 X .75 IN	1	NA		
9	074-761	HOLE PLUG 1/2 HOLE NYLON BLACK	2	NA	83330	3092
10	193-9213	SPACER, LOCKING	6	NA		
12	NAS1635-04LR4	SCR PAN HD SELFLOCK, 4-40 X 1/4	6	NA		
13	074-921	FEET NON-SKID	4	NA	4963 4963 24803	SJ-5008 BLACK SJ-5008SP KFT12-BLK
14	NAS662C2R4	SCR FLAT HD 2-56 X 1/4 LG 100	6	NA		
18	193-8135	WIRING DIAGRAM, ATTEN UNIT MODEL 8310, +15V W/ETHERNET	0	NA		
19	089-4052	ICD, ATTEN UNIT MODEL 8310 (75 OHM) W/ETHERNET (+15V)	0	NA		
20	IM493	O & S MANUAL, MODEL 8310 W/ETHERNET	1	NA		

Refer to Aeroflex / Weinschel Drawing 193-7001-6, Rev. A for parts location.

Model 8310-2-FN / -RN, Attenuator Unit Assembly Replaceable Parts List (P/N 193-7002-3, Rev. A):

Find No.	Part Number	Description	Quantity Used	Reference Designator	CAGE Code	Vendor Part Number
1	193-8034-3	ASSY, BASE UNIT, W/ETHERNET (+15V)	1	NA		
2	193-9207	MOUNTING PLATE	1	NA		
3	3250T-63	ATTEN PRGM, 63 dB/1 dB STEPS 75 OHMS	1	AT1		
4	193-9209	ASSY, CABLE, CONT TO ATTENUATORS	1	W7		
6	068-73-11/0	CABLE COAXIAL BNC-M TO F-M 75 OHMS	1	W10	93459	B068-73-11/0
7	068-73-15/0	CABLE COAXIAL BNC-M TO F-M 75 OHMS	1	W11	93459	B068-73-15/0
8	090-301	* LABEL STD 1.5 X .75 IN	1	NA		
9	074-761	HOLE PLUG 1/2 HOLE NYLON BLACK	6	NA	83330	3092
11	063-277	ADAPTER, F-JACK TO F-JACK	2	NA	43321	BA330A
12	NAS1635-04LR4	SCR PAN HD SELFLOCK 4-40 X 1/4	6	NA		
13	074-921	FEET NON-SKID	4	NA	4963 4963 24803	SJ-5008 BLACK SJ-5008SP KFT12-BLK
14	NAS662C2R4	SCR FLAT HD 2-56 X 1/4 LG 100	2	NA		
18	193-8135	WIRING DIAGRAM, ATTEN UNIT MODEL 8310, +15V W/ETHERNET	0	NA		
19	089-4052	ICD, ATTEN UNIT MODEL 8310 (75 OHM) W/ETHERNET (+15V)	0	NA		
20	IM493	O & S MANUAL, MODEL 8310 W/ETHERNET	1	NA		

Refer to Aeroflex / Weinschel Drawing 193-7002-3, Rev. A for parts location.

Model 8310-2-2-FN / -RN, Attenuator Unit Assembly Replaceable Parts List (P/N 193-7002-4, Rev. A):

Find No.	Part Number	Description	Quantity Used	Reference Designator	CAGE Code	Vendor Part Number
1	193-8034-3	ASSY, BASE UNIT, W/ETHERNET (+15V)	1	NA		
2	193-9207	MOUNTING PLATE	1	NA		
3	3250T-63	ATTEN PRGM, 63 dB/1 dB STEPS, 75 OHMS	1	AT1		
4	193-8122	ASSY, CABLE, CONTROL	1	W7		
6	068-56-11/0	COAXIAL CABLE ASSY, BNC MALE TO FEMALE BULKHEAD, 75 OHM	1	W10	93459	B068-56-11/0
7	068-56-15/0	COAXIAL CABLE ASSY, BNC MALE TO FEMALE BULKHEAD, 75 OHM	1	W11	93459	B068-56/15/0
8	090-301	* LABEL STD 1.5 X .75 IN	1	NA		
9	074-761	HOLE PLUG 1/2 HOLE NYLON BLACK	6	NA	83330	3092
10	193-9213	SPACER, LOCKING	2	NA		
13	074-921	FEET NON-SKID	4	NA	4963 4963 24803	SJ-5008 BLACK SJ-5008SP KFT12-BLK
14	NAS662C2R4	SCR FLAT HD 2-56 X 1/4 LG 100	2	NA		
15	NAS1635-04LR4	SCR PAN HD SELFLOCK 4-40 X 1/4	6	NA		
18	193-8135	WIRING DIAGRAM, ATTEN UNIT MODEL 8310, +15V W/ETHERNET	0	NA		
19	089-4052	ICD, ATTEN UNIT MODEL 8310 (75 OHM) W/ETHERNET (+15V)	0	NA		
20	IM493	O & S MANUAL, MODEL 8310 W/ETHERNET	1	NA		

Refer to Aeroflex / Weinschel Drawing 193-7002-4, Rev. A for parts location.

Model 8310-35-FN / -RN Attenuator Unit Assembly Replaceable Parts List (P/N 193-7035-9, Rev. A):

Find No.	Part Number	Description	Quantity Used	Reference Designator	CAGE Code	Vendor Part Number
1	193-8034-3	ASSY, BASE UNIT W/ETHERNET (+15V)	1	NA		
2	193-8039	MOUNTING PLATE	1	NA		
3	3200T-1	ATTEN PRGM SMARTSTEP	1	AT1		
4	7004A-1	PLANAR BULKHEAD, 2.92 FEMALE	2	NA		
5	7005A-3	PLANAR CROWN, TYPE N FEMALE	2	NA		
6	068-32-4/0	COAXIAL CABLE ASSY, SMA M/M, CONFORMABLE, DC TO 18 GHz	1	W10		068-32-4
7	068-32-12/0	COAXIAL CABLE ASSY, SMA M/M, CONFORMABLE, DC TO 18 GHz	1	W11	93459	B068-32-12
8	193-8041	ASSY, CABLE, CONTROLLER TO ATTENUATORS	1	W7		
11	090-301	* LABEL STD, 1.5 X .75 IN	1	NA		
12	074-761-1	HOLE PLUG 3/8 HOLE NYLON BLACK	6	NA	83330	3091
13	074-921	FEET NON-SKID	4	NA	4963 4963 24803	SJ-5008 BLACK SJ-5008SP KFT12-BLK
14	MS24693-C3	SCR FLAT HD 4-40 X 5/16 LG 100	2	NA		
15	NAS1635-04LR4	SCR PAN HD SELFLOCK 4-40 X 1/4	6	NA		
18	193-8135	WIRING DIAGRAM, ATTEN UNIT, 8310 +15V W/ETHERNET	0	NA		
19	089-4051	ICD, ATTEN UNIT, 8310 W/ETHERNET	0	NA		
20	IM493	O & S MANUAL MODEL 8310 W/ETHERNET	1	NA		

Refer to Aeroflex / Weinschel Drawing 193-7035-9, Rev. A for parts location.

Model 8310-35-2-FN / -RN Attenuator Unit Assembly Replaceable Parts List (P/N 193-7035-10, Rev. A):

Find No.	Part Number	Description	Quantity Used	Reference Designator	CAGE Code	Vendor Part Number
1	193-8034-3	ASSY, BASE UNIT W/ETHERNET (+15V)	1	NA		
2	193-8039	MOUNTING PLATE	1	NA		
3	3200T-1	ATTEN PRGM SMARTSTEP	2	AT1, AT2		
4	7004A-1	PLANAR BULKHEAD, 2.92 FEMALE	4	NA		
5	7005A-3	PLANAR CROWN, TYPE N FEMALE	4	NA		
6	068-32-4/0	COAXIAL CABLE ASSY, SMA M/M, CONFORMABLE, DC TO 18 GHz	2	W10, W12		068-32-4
7	068-32-12/0	COAXIAL CABLE ASSY, SMA M/M, CONFORMABLE, DC TO 18 GHz	2	W11, W13	93459	B068-32-12
8	193-8041	ASSY, CABLE, CONTROLLER TO ATTENUATORS	1	W7		
11	090-301	* LABEL STD, 1.5 X .75 IN 1.5 X .75 IN	1	NA		
12	074-761-1	HOLE PLUG 3/8 HOLE NYLON BLACK	4	NA	83330	3091
13	074-921	FEET NON-SKID	4	NA	4963 4963 24803	SJ-5008 BLACK SJ-5008SP KFT12-BLK
14	MS24693-C3	SCR FLAT HD 4-40 X 5/16 LG 100	4	NA		
15	NAS1635-04LR4	SCR PAN HD SELFLOCK 4-40 X 1/4	6	NA		
18	193-8135	WIRING DIAGRAM, ATTEN UNIT, 8310 +15V W/ETHERNET	0	NA		
19	089-4051	ICD, ATTEN UNIT, 8310 W/ETHERNET	0	NA		
20	IM493	O & S MANUAL MODEL 8310 W/ETHERNET	1	NA		

Refer to Aeroflex / Weinschel Drawing 193-7035-10, Rev. A for parts location.

Model 8310-35-3-TN Attenuator Unit Assembly Replaceable Parts List (P/N 193-7035-11, Rev. A):

Find No.	Part Number	Description	Quantity Used	Reference Designator	CAGE Code	Vendor Part Number
1	193-8034-3	ASSY, BASE UNIT W/ETHERNET (+15V)	1	NA		
2	193-8039	MOUNTING PLATE	1	NA		
3	3200T-1	ATTEN PRGM SMARTSTEP	3	AT1 - AT3		
4	7004A-1	PLANAR BULKHEAD, 2.92 FEMALE	6	NA		
5	7005A-3	PLANAR CROWN, TYPE N FEMALE	6	NA		
6	068-32-4/0	COAXIAL CABLE ASSY, SMA M/M, CONFORMABLE, DC TO 18 GHZ	6	W10 - W15 W15		B068-32-4
8	193-8041	ASSY, CABLE, CONTROLLER TO ATTENUATORS	1	W7		
11	090-301	* LABEL STD, 1.5 X .75 IN	1	NA		
12	074-761-1	HOLE PLUG 3/8 HOLE NYLON BLACK NYLON BLACK	2	NA	83330	3091
13	074-921	FEET NON-SKID	4	NA	4963 4963 24803	SJ-5008 BLACK SJ-5008SP KFT12-BLK
14	MS24693-C3	SCR FLAT HD 4-40 X 5/16 LG 100	6	NA		
15	NAS1635-04LR4	SCR PAN HD SELFLOCK 4-40 X 1/4	6	NA		
18	193-8135	WIRING DIAGRAM, ATTEN UNIT, 8310 +15V W/ETHERNET	0	NA		
19	089-4051	ICD, ATTEN UNIT, 8310 W/ETHERNET	0	NA		
20	IM493	O & S MANUAL MODEL 8310 W/ETHERNET	1	NA		

Refer to Aeroflex / Weinschel Drawing 193-7035-11, Rev. A for parts location.

Model 8310-35-4-TN Attenuator Unit Assembly Replaceable Parts List (P/N 193-7035-12, Rev. A):

Find No.	Part Number	Description	Quantity Used	Reference Designator	CAGE Code	Vendor Part Number
1	193-8034-3	ASSY, BASE UNIT W/ETHERNET (+15V)	1	NA		
2	193-8039	MOUNTING PLATE	1	NA		
3	3200T-1	ATTEN PRGM SMARTSTEP	4	AT1 - AT4		
4	7004A-1	PLANAR BULKHEAD, 2.92 FEMALE	8	NA		
5	7005A-3	PLANAR CROWN, TYPE N FEMALE	8	NA		
6	068-32-4/0	COAXIAL CABLE ASSY, SMA M/M, CONFORMABLE, DC TO 18 GHZ	8	W10 -W17		B068-32-4
8	193-8041	ASSY, CABLE, CONTROLLER TO ATTENUATORS	1	W7		
11	090-301	* LABEL STD, 1.5 X .75 IN	1	NA		
13	074-921	FEET NON-SKID	4	NA	4963 4963 24803	SJ-5008 BLACK SJ-5008SP KFT12-BLK
14	MS24693-C3	SCR FLAT HD 4-40 X 5/16 LG 100	8	NA		
15	NAS1635-04LR4	SCR PAN HD SELFLOCK 4-40 X 1/4	6	NA		
18	193-8135	WIRING DIAGRAM, ATTEN UNIT, 8310 +15V W/ETHERNET	0	NA		
19	089-4051	ICD, ATTEN UNIT, 8310 W/ETHERNET	0	NA		
20	IM493	O & S MANUAL MODEL 8310 W/ETHERNET	1	NA		

Refer to Aeroflex / Weinschel Drawing 193-7035-12, Rev. A for parts location.

Model 8310-35-F / R-EN, Attenuator Unit Assembly Replaceable Parts List (P/N 193-7035-13, Rev. A):

Find No.	Part Number	Description	Quantity Used	Reference Designator	CAGE Code	Vendor Part Number
1	193-8034-3	ASSY, BASE UNIT W/ETHERNET (+15V)	1	NA		
2	193-8039	MOUNTING PLATE	1	NA		
3	3200T-1E	ATTEN PRGM SMARTSTEP	1	AT1		
4	7004A-1	PLANAR BULKHEAD, 2.92 FEMALE	2	NA		
5	7005A-3	PLANAR CROWN, TYPE N FEMALE	2	NA		
6	068-32-4/0	COAXIAL CABLE ASSY, SMA M/M, CONFORMABLE, DC TO 18 GHz	1	W10		B068-32-4
7	068-32-12/0	COAXIAL CABLE ASSY SMA M/M, CONFORMABLE	1	W11	93459	B068-32-12
8	193-8041	ASSY, CABLE, CONTROLLER TO ATTENUATORS	1	W7		
11	090-301	* LABEL STD, 1.5 X .75 IN	1	NA		
12	074-761-1	HOLE PLUG 3/8 HOLE NYLON BLACK	6	NA	83330	3091
13	074-921	FEET NON-SKID	4	NA	4963	SJ-5008 BLACK
					4963	SJ-5008SP
					24803	KFT12-BLK
14	MS24693-C3	SCR FLAT HD 4-40 X 5/16 LG 100	2	NA		
15	NAS1635-04LR4	SCR PAN HD SELFLOCK 4-40 X 1/4	6	NA		
18	193-8135	WIRING DIAGRAM, ATTEN UNIT, 8310 +15V W/ETHERNET	0	NA		
19	089-4051	ICD, ATTEN UNIT, 8310 W/ETHERNET	0	NA		
20	IM493	O & S MANUAL MODEL 8310 W/ETHERNET	1	NA		

Refer to Aeroflex / Weinschel Drawing 193-7035-13, Rev. A for parts location.

Model 8310-35-2-F / R -EN, Attenuator Unit Assembly Replaceable Parts List (P/N 193-7035-14, Rev. A):

Find No.	Part Number	Description	Quantity Used	Reference Designator	CAGE Code	Vendor Part Number
1	193-8034-3	ASSY, BASE UNIT W/ETHERNET (+15V)	1	NA		
2	193-8039	MOUNTING PLATE	1	NA		
3	3200T-1E	ATTEN PRGM SMARTSTEP	2	AT1, AT2		
4	7004A-1	PLANAR BULKHEAD, 2.92 FEMALE	4	NA		
5	7005A-3	PLANAR CROWN, TYPE N FEMALE	4	NA		
6	068-32-4/0	COAXIAL CABLE ASSY, SMA M/M, CONFORMABLE, DC TO 18 GHz	2	W10, W12		B068-32-4
7	068-32-12/0	COAXIAL CABLE ASSY, SMA M/M, CONFORMABLE, DC TO 18 GHz	2	W11, W13	93459	B068-32-12
8	193-8041	ASSY, CABLE, CONTROLLER TO ATTENUATORS	1	W7		
11	090-301	* LABEL STD, 1.5 X .75 IN	1	NA		
12	074-761-1	HOLE PLUG 3/8 HOLE NYLON BLACK	4	NA	83330	3091
13	074-921	FEET NON-SKID	4	NA	4963	SJ-5008 BLACK
					4963	SJ-5008SP
					24803	KFT12-BLK
14	MS24693-C3	SCR FLAT HD 4-40 X 5/16 LG 100	4	NA		
15	NAS1635-04LR4	SCR PAN HD SELFLOCK 4-40 X 1/4	6	NA		
18	193-8135	WIRING DIAGRAM, ATTEN UNIT, 8310 +15V W/ETHERNET	0	NA		
19	089-4051	ICD, ATTEN UNIT, 8310 W/ETHERNET	0	NA		
20	IM493	O & S MANUAL MODEL 8310 W/ETHERNET	1	NA		

Refer to Aeroflex / Weinschel Drawing 193-7035-14, Rev. A for parts location.

MODEL 8310-35-3-T-EN, ATTENUATOR UNIT ASSEMBLY REPLACEABLE PARTS LIST (P/N 193-7035-15, REV. A):

Find No.	Part Number	Description	Quantity Used	Reference Designator	CAGE Code	Vendor Part Number
1	193-8034-3	ASSY, BASE UNIT W/ETHERNET (+15V)	1	NA		
2	193-8039	MOUNTING PLATE	1	NA		
3	3200T-1E	ATTEN PRGM SMARTSTEP	3	AT1 - AT3		
4	7004A-1	PLANAR BULKHEAD, 2.92 FEMALE	6	NA		
5	7005A-3	PLANAR CROWN, TYPE N FEMALE	6	NA		
6	068-32-4/0	COAXIAL CABLE ASSY, SMA M/M, CONFORMABLE, DC TO 18 GHz	6	W10 - W15		B068-32-4
8	193-8041	ASSY, CABLE, CONTROLLER TO ATTENUATORS	1	W7		
11	090-301	* LABEL STD, 1.5 X .75 IN	1	NA		
12	074-761-1	HOLE PLUG 3/8 HOLE NYLON BLACK	2	NA	83330	3091
13	074-921	FEET NON-SKID	4	NA	4963 4963 24803	SJ-5008 BLACK SJ-5008SP KFT12-BLK
14	MS24693-C3	SCR FLAT HD 4-40 X 5/16 LG 100	6	NA		
15	NAS1635-04LR4	SCR PAN HD SELFLOCK 4-40 X 1/4	6	NA		
18	193-8135	WIRING DIAGRAM, ATTEN UNIT, 8310 +15V W/ETHERNET	0	NA		
19	089-4051	ICD, ATTEN UNIT, 8310 W/ETHERNET	0	NA		
20	IM493	O & S MANUAL MODEL 8310 W/ETHERNET	1	NA		

Refer to Aeroflex / Weinschel Drawing 193-7035-15, Rev. A for parts location.

Model 8310-35-4-T-EN, Attenuator Unit Assembly Replaceable Parts List (P/N 193-7035-16, Rev. A):

Find No.	Part Number	Description	Quantity Used	Reference Designator	CAGE Code	Vendor Part Number
1	193-8034-3	ASSY, BASE UNIT W/ETHERNET (+15V)	1	NA		
2	193-8039	MOUNTING PLATE	1	NA		
3	3200T-1E	ATTEN PRGM SMARTSTEP	4	AT1 - AT4		
4	7004A-1	PLANAR BULKHEAD, 2.92 FEMALE	8	NA		
5	7005A-3	PLANAR CROWN, TYPE N FEMALE	8	NA		
6	068-32-4/0	COAXIAL CABLE ASSY, SMA M/M, CONFORMABLE, DC TO 18 GHz	8	W10 - W17		B068-32-4
8	193-8041	ASSY, CABLE, CONTROLLER TO ATTENUATORS	1	W7		
11	090-301	* LABEL STD, 1.5 X .75 IN	1	NA		
13	074-921	FEET NON-SKID	4	NA	4963 4963 24803	SJ-5008 BLACK SJ-5008SP KFT12-BLK
14	MS24693-C3	SCR FLAT HD 4-40 X 5/16 LG 100	8	NA		
15	NAS1635-04LR4	SCR PAN HD SELFLOCK, 4-40 X 1/4	6	NA		
18	193-8135	WIRING DIAGRAM, ATTEN UNIT, 8310 +15V W/ETHERNET	0	NA		
19	089-4051	ICD, ATTEN UNIT, 8310 W/ETHERNET	0	NA		
20	IM493	O & S MANUAL MODEL 8310 W/ETHERNET	1	NA		

Refer to Aeroflex / Weinschel Drawing 193-7035-16, Rev. A for parts location.

Model 8310-36-FN / -RN Attenuator Unit Assembly Replaceable Parts List (P/N 193-7036-8):

Find No.	Part Number	Description	Quantity Used	Reference Designator	CAGE Code	Vendor Part Number
1	193-8034-3	ASSY, BASE UNIT W/ETHERNET (+15V)	1	NA		
2	193-8039	MOUNTING PLATE	1	NA		
3	3209T-1	ATTEN PRGM, SMARTSTEP	1	AT1		
4	7004A-1	PLANAR BULKHEAD, 2.92 FEMALE	2	NA		
5	7005A-3	PLANAR CROWN, TYPE N FEMALE	2	NA		
6	068-32-4/0	COAXIAL CABLE ASSY, SMA M/M, CONFORMABLE, DC TO 18 GHZ	1	W9		B068-32-4/0
7	068-32-12/0	COAXIAL CABLE ASSY, SMA M/M, CONFORMABLE, DC TO 18 GHZ	1	W8	93459	B068-32-12/0
8	193-8044	ASSY, CABLE, CONTR TO ATTENS	1	W7		
11	090-301	* LABEL STD, 1.5 X .75 IN	1	NA		
12	074-761-1	HOLE PLUG 3/8 HOLE, NYLON BLACK	6	NA	83330	3091
13	074-921	FEET NON-SKID	4	NA	4963 4963 24803	SJ-5008 BLACK SJ-5008SP KFT12-BLK
14	MS24693-C3	SCR FLAT HD 4-40 X 5/16 LG 100	2	NA		
15	NAS1635-04LR4	SCR PAN HD SELFLOCK 4-40 X 1/4	6	NA		
18	193-8135	WIRING DIAGRAM, ATTEN UNIT MODEL 8310, +15V W/ETHERNET	0	NA		
19	089-4051	ICD, ATTEN UNIT, W/ETHERNET (+15V)	0	NA		
20	IM493	O & S MANUAL, MODEL 8310 W/ETHERNET	1	NA		

Refer to Aeroflex / Weinschel Drawing 193-7036-8, Rev. A for parts location.

Model 8310-36-2-FN / -RN Attenuator Unit Assembly Replaceable Parts List (P/N 193-7038-9, Rev. A):

Find No.	Part Number	Description	Quantity Used	Reference Designator	CAGE Code	Vendor Part Number
1	193-8034-3	ASSY, BASE UNIT W/ETHERNET (+15V)	1	NA		
2	193-8039	MOUNTING PLATE	1	NA		
3	3209T-1	ATTEN PRGM, SMARTSTEP	2	AT1, AT2		
4	7004A-1	PLANAR BULKHEAD, 2.92 FEMALE	4	NA		
5	7005A-3	PLANAR CROWN, TYPE N FEMALE	4	NA		
6	068-32-4/0	COAXIAL CABLE ASSY, SMA M/M, CONFORMABLE, DC TO 18 GHZ	2	W9, W11		B068-32-4/0
7	068-32-12/0	COAXIAL CABLE ASSY, SMA M/M, CONFORMABLE, DC TO 18 GHZ	2	W8, W10	93459	B068-32-12/0
8	193-8044	ASSY, CABLE, CONTR TO ATTENS	1	W7		
11	090-301	* LABEL STD, 1.5 X .75 IN	1	NA		
12	074-761-1	HOLE PLUG 3/8 HOLE, NYLON BLACK	4	NA	83330	3091
13	074-921	FEET NON-SKID	4	NA	4963 4963 24803	SJ-5008 BLACK SJ-5008SP KFT12-BLK
14	MS24693-C3	SCR FLAT HD 4-40 X 5/16 LG 100	4	NA		
15	NAS1635-04LR4	SCR PAN HD SELFLOCK, 4-40 X 1/4	6	NA		
18	193-8135	WIRING DIAGRAM, ATTEN UNIT MODEL 8310, +15V W/ETHERNET	0	NA		
19	089-4051	ICD, ATTEN UNIT, W/ETHERNET (+15V)	0	NA		
20	IM493	O & S MANUAL, MODEL 8310 W/ETHERNET	1	NA		

Refer to Aeroflex / Weinschel Drawing 193-7038-9, Rev. A for parts location.

Model 8310-36-3-TN Attenuator Unit Assembly Replaceable Parts List (P/N 193-7038-10, Rev. A):

Find No.	Part Number	Description	Quantity Used	Reference Designator	CAGE Code	Vendor Part Number
1	193-8034-3	ASSY, BASE UNIT W/ETHERNET (+15V)	1			
2	193-8039	MOUNTING PLATE	1			
3	3209T-1	ATTEN PRGM, SMARTSTEP	3	AT1 - AT3		
4	7004A-1	PLANAR BULKHEAD, 2.92 FEMALE	6	NA		
5	7005A-3	PLANAR CROWN, TYPE N FEMALE	6	NA		
6	068-32-4/0	COAXIAL CABLE ASSY, SMA M/M, CONFORMABLE, DC TO 18 GHz	6	W8 - W13		B068-32-4/0
8	193-8044	ASSY, CABLE, CONTR TO ATTENS CONTROLLER TO ATTENS	1	W7		
11	090-301	* LABEL STD, 1.5 X .75 IN	1	NA		
12	074-761-1	HOLE PLUG 3/8 HOLE, NYLON BLACK	2	NA	83330	3091
13	074-921	FEET NON-SKID	4	NA	4963 4963 24803	SJ-5008 BLACK SJ-5008SP KFT12-BLK
14	MS24693-C3	SCR FLAT HD 4-40 X 5/16 LG 100	6	NA		
15	NAS1635-04LR4	SCR PAN HD SELFLOCK, 4-40 X 1/4	6	NA		
18	193-8135	WIRING DIAGRAM, ATTEN UNIT MODEL 8310, +15V W/ETHERNET	0			
19	089-4051	ICD, ATTEN UNIT, W/ETHERNET (+15V)	0			
20	IM493	O & S MANUAL, MODEL 8310 W/ETHERNET	1			

Refer to Aeroflex / Weinschel Drawing 193-7038-10, Rev. A for parts location.

Model 8310-36-F-EN / -R-EN Attenuator Unit Assembly Replaceable Parts List (P/N 193-7036-11, Rev. A):

Find No.	Part Number	Description	Quantity Used	Reference Designator	CAGE Code	Vendor Part Number
1	193-8034-3	ASSY, BASE UNIT W/ETHERNET (+15V)	1	NA		
2	193-8039	MOUNTING PLATE	1	NA		
3	3209T-1E	ATTEN PRGM, W/SMARTSTEP	1	AT1		
4	7004A-1	PLANAR BULKHEAD, 2.92 FEMALE	2	NA		
5	7005A-3	PLANAR CROWN, TYPE N FEMALE	2	NA		
6	068-32-4/0	COAXIAL CABLE ASSY, SMA M/M, CONFORMABLE, DC TO 18 GHZ	1	W9		B068-32-4/0
7	068-32-12/0	COAXIAL CABLE ASSY, SMA M/M, CONFORMABLE, DC TO 18 GHZ	1	W8	93459	B068-32-12/0
8	193-8044	ASSY, CABLE, CONTR TO ATTENS	1	W7		
11	090-301	* LABEL STD, 1.5 X .75 IN	1	NA		
12	074-761-1	HOLE PLUG 3/8 HOLE, NYLON BLACK	6	NA	83330	3091
13	074-921	FEET NON-SKID	4	NA	4963	SJ-5008 BLACK
					4963	SJ-5008SP
					24803	KFT12-BLK
14	MS24693-C3	SCR FLAT HD 4-40 X 5/16 LG 100	2	NA		
15	NAS1635-04LR4	SCR PAN HD SELFLOCK, 4-40 X 1/4	6	NA		
18	193-8135	WIRING DIAGRAM, ATTEN UNIT MODEL 8310, +15V W/ETHERNET	0	NA		
19	089-4051	ICD, ATTEN UNIT, W/ETHERNET (+15V)	0	NA		
20	IM493	O & S MANUAL, MODEL 8310 W/ETHERNET	1	NA		

Refer to Aeroflex / Weinschel Drawing 193-7036-11, Rev. A for parts location.

Model 8310-36-2-F-EN / -R-EN Attenuator Unit Assembly Replaceable Parts List (P/N 193-7038-12, Rev. A):

Find No.	Part Number	Description	Quantity Used	Reference Designator	CAGE Code	Vendor Part Number
1	193-8034-3	ASSY, BASE UNIT W/ETHERNET (+15V)	1	NA		
2	193-8039	MOUNTING PLATE	1	NA		
3	3209T-1E	ATTEN PRGM, W/SMARTSTEP	2	AT1, AT2		
4	7004A-1	PLANAR BULKHEAD, 2.92 FEMALE	4	NA		
5	7005A-3	PLANAR CROWN, TYPE N FEMALE	4	NA		
6	068-32-4/0	COAXIAL CABLE ASSY, SMA M/M, CONFORMABLE, DC TO 18 GHZ	2	W9, W11		B068-32-4/0
7	068-32-12/0	COAXIAL CABLE ASSY, SMA M/M, CONFORMABLE, DC TO 18 GHZ	2	W8, W10	93459	B068-32-12/0
8	193-8044	ASSY, CABLE, CONTR TO ATTENS	1	W7		
11	090-301	* LABEL STD 1.5 X .75 IN	1	NA		
12	074-761-1	HOLE PLUG 3/8 HOLE, NYLON BLACK	4	NA	83330	3091
13	074-921	FEET NON-SKID	4	NA	4963	SJ-5008 BLACK
					4963	SJ-5008SP
					24803	KFT12-BLK
14	MS24693-C3	SCR FLAT HD 4-40 X 5/16 LG 100	4	NA		
15	NAS1635-04LR4	SCR PAN HD SELFLOCK, 4-40 X 1/4	6	NA		
18	193-8135	WIRING DIAGRAM, ATTEN UNIT MODEL 8310, +15V W/ETHERNET	0	NA		
19	089-4051	ICD, ATTEN UNIT, W/ETHERNET (+15V)	0	NA		
20	IM493	O & S MANUAL, MODEL 8310 W/ETHERNET	1	NA		

Refer to Aeroflex / Weinschel Drawing 193-7038-12, Rev. A for parts location.

Model 8310-36-3-T-EN Attenuator Unit Assembly Replaceable Parts List (P/N 193-7038-13, Rev. A):

Find No.	Part Number	Description	Quantity Used	Reference Designator	CAGE Code	Vendor Part Number
1	193-8034-3	ASSY, BASE UNIT W/ETHERNET (+15V)	1	NA		
2	193-8039	MOUNTING PLATE	1	NA		
3	3209T-1E	ATTEN PRGM W/SMARTSTEP	3	AT1-AT3		
4	7004A-1	PLANAR BULKHEAD, 2.92 FEMALE	6	NA		
5	7005A-3	PLANAR CROWN, TYPE N FEMALE	6	NA		
6	068-32-4/0	COAXIAL CABLE ASSY, SMA M/M, CONFORMABLE, DC TO 18 GHz	6	W8 - W13		A068-32-4/0
8	193-8044	ASSY, CABLE, CONT TO ATTENS	1	W7		
11	090-301	* LABEL STD, 1.5 X .75 IN	1	NA		
12	074-761-1	HOLE PLUG 3/8 HOLE, NYLON BLACK	2	NA	83330	3091
13	074-921	FEET NON-SKID	4	NA	4963 4963 24803	SJ-5008 BLACK SJ-5008SP KFT12-BLK
14	MS24693-C3	SCR FLAT HD 4-40 X 5/16 LG 100	6	NA		
15	NAS1635-04LR4	SCR PAN HD SELFLOCK 4-40 X 1/4	6	NA		
18	193-8135	WIRING DIAGRAM, ATTEN UNIT MODEL 8310, +15V W/ETHERNET	0	NA		
19	089-4051	ICD, ATTEN UNIT, W/ETHERNET (+15V)	0	NA		
20	IM493	O & S MANUAL, MODEL 8310 W/ETHERNET	1	NA		

Refer to Aeroflex / Weinschel Drawing 193-7038-13, Rev. A for parts location.

Model 8310-38-FN / -RN Attenuator Unit Assembly Replaceable Parts List (P/N 193-7038-9, Rev. A):

Find No.	Part Number	Description	Quantity Used	Reference Designator	CAGE Code	Vendor Part Number
1	193-8034-3	ASSY, BASE UNIT, W/ETHERNET (+15V)	1	NA		
2	193-8039	MOUNTING PLATE	1	NA		
3	3206T-1	ATTEN PRGM, SMARTSTEP	1	AT1		
4	7004A-1	PLANAR BULKHEAD, 2.92 FEMALE	2	NA		
5	7005A-3	PLANAR CROWN, TYPE N FEMALE	2	NA		
6	068-32-4/0	COAXIAL CABLE ASSY, SMA M/M, CONFORMABLE, DC TO 18 GHZ	1	W8		B068-32-4/0
7	068-32-12/0	COAXIAL CABLE ASSY, SMA M/M, CONFORMABLE, DC TO 18 GHZ	1	W9	93459	B068-32-12/0
8	193-8041	ASSY, CABLE, CONTROLLER TO ATTENUATORS	1	W7		
11	090-301	* LABEL STD, 1.5 X .75 IN	1	NA		
12	074-761-1	HOLE PLUG 3/8 HOLE NYLON BLACK	6	NA	83330	3091
13	074-921	FEET NON-SKID	4	NA	4963 4963 24803	SJ-5008 BLACK SJ-5008SP KFT12-BLK
14	MS24693-C3	SCR FLAT HD 4-40 X 5/16 LG 100	2	NA		
15	NAS1635-04LR4	SCR PAN HD SELFLOCK 4-40 X 1/4	6	NA		
18	193-8135	WIRING DIAGRAM, ATTEN UNIT MODEL 8310, +15V W/ETHERNET	0	NA		
19	089-4051	ICD, ATTEN UNIT, W/ETHERNET (+15V)	0	NA		
20	IM493	O & S MANUAL, MODEL 8310 W/ETHERNET	1	NA		

Refer to Aeroflex / Weinschel Drawing 193-7038-9, Rev. A for parts location.

Model 8310-38-2-FN / -RN Attenuator Unit Assembly Replaceable Parts List (P/N 193-7038-10, Rev. A):

Find No.	Part Number	Description	Quantity Used	Reference Designator	CAGE Code	Vendor Part Number
1	193-8034-3	ASSY, BASE UNIT, W/ETHERNET (+15V)	1	NA		
2	193-8039	MOUNTING PLATE	1	NA		
3	3206T-1	ATTEN PRGM SMARTSTEP	2	AT1, AT2		
4	7004A-1	PLANAR BULKHEAD 2.92 FEMALE	4	NA		
5	7005A-3	PLANAR CROWN, TYPE N FEMALE	4	NA		
6	068-32-4/0	COAXIAL CABLE ASSY, SMA M/M, CONFORMABLE, DC TO 18 GHZ	2	W8, W10		B068-32-4/0
7	068-32-12/0	COAXIAL CABLE ASSY, SMA M/M, CONFORMABLE, DC TO 18 GHZ	2	W9, W11	93459	B068-32-12/0
8	193-8041	ASSY, CABLE, CONTROLLER TO ATTENUATORS	1	W7		
11	090-301	* LABEL STD, 1.5 X .75 IN	1	NA		
12	074-761-1	HOLE PLUG 3/8 HOLE NYLON BLACK	4	NA	83330	3091
13	074-921	FEET NON-SKID	4	NA	4963 4963 24803	SJ-5008 BLACK SJ-5008SP KFT12-BLK
14	MS24693-C3	SCR FLAT HD 4-40 X 5/16 LG 100	4	NA		
15	NAS1635-04LR4	SCR PAN HD SELFLOCK 4-40 X 1/4	6	NA		
18	193-8135	WIRING DIAGRAM, ATTEN UNIT MODEL 8310, +15V W/ETHERNET	0	NA		
19	089-4051	ICD, ATTEN UNIT, W/ETHERNET (+15V)	0	NA		
20	IM493	O & S MANUAL, MODEL 8310 W/ETHERNET	1	NA		

Refer to Aeroflex / Weinschel Drawing 193-7038-10, Rev. A for parts location.

Model 8310-38-3-TN Attenuator Unit Assembly Replaceable Parts List (P/N 193-7038-11, Rev. A):

Find No.	Part Number	Description	Quantity Used	Reference Designator	CAGE Code	Vendor Part Number
1	193-8034-3	ASSY, BASE UNIT, W/ETHERNET (+15V)	1	NA		
2	193-8039	MOUNTING PLATE	1	NA		
3	3206T-1	ATTEN PRGM, SMARTSTEP	3	AT1 - AT3		
4	7004A-1	PLANAR BULKHEAD 2.92 FEMALE	6	NA		
5	7005A-3	PLANAR CROWN, TYPE N FEMALE	6	NA		
6	068-32-4/0	COAXIAL CABLE ASSY, SMA M/M, CONFORMABLE, DC TO 18 GHz	6	W8 - W13		B068-32-4/0
8	193-8041	ASSY, CABLE, CONTROLLER TO ATTENUATORS	1	W7		
11	090-301	* LABEL STD, 1.5 X .75 IN	1	NA		
12	074-761-1	HOLE PLUG 3/8 HOLE NYLON BLACK	4	NA	83330	3091
13	074-921	FEET NON-SKID	4	NA	4963	SJ-5008 BLACK
					4963	SJ-5008SP
					24803	KFT12-BLK
14	MS24693-C3	SCR FLAT HD 4-40 X 5/16 LG 100	4	NA		
15	NAS1635-04LR4	SCR PAN HD SELFLOCK 4-40 X 1/4	6	NA		
18	193-8135	WIRING DIAGRAM, ATTEN UNIT MODEL 8310, +15V W/ETHERNET	0	NA		
19	089-4051	ICD, ATTEN UNIT, W/ETHERNET (+15V)	0	NA		
20	IM493	O & S MANUAL, MODEL 8310 W/ETHERNET	1	NA		

Refer to Aeroflex / Weinschel Drawing 193-7038-, Rev. A for parts location.

Model 8310-38-4-TN, Attenuator Unit Assembly Replaceable Parts List (P/N 193-7038-12, Rev. A):

Find No.	Part Number	Description	Quantity Used	Reference Designator	CAGE Code	Vendor Part Number
1	193-8034-3	ASSY, BASE UNIT W/ETHERNET (+15V)	1	NA		
2	193-8039	MOUNTING PLATE	1	NA		
3	3206T-1	ATTEN PRGM SMARTSTEP	4	AT1 - AT4		
4	7004A-1	PLANAR BULKHEAD 2.92 FEMALE	8	NA		
5	7005A-3	PLANAR CROWN, TYPE N FEMALE	8	NA		
6	068-32-4/0	COAXIAL CABLE ASSY, SMA M/M, CONFORMABLE, DC TO 18 GHz	8	W10 - W17		B068-32-4/0
8	193-8041	ASSY, CABLE, CONTROLLER TO ATTENUATORS	1	W7		
11	090-301	* LABEL STD, 1.5 X .75 IN	1	NA		
13	074-921	FEET NON-SKID	4	NA	4963	SJ-5008 BLACK
					4963	SJ-5008SP
					24803	KFT12-BLK
14	MS24693-C3	SCR FLAT HD 4-40 X 5/16 LG 100	8	NA		
15	NAS1635-04LR4	SCR PAN HD SELFLOCK 4-40 X 1/4	6	NA		
18	193-8135	WIRING DIAGRAM, ATTEN UNIT MODEL 8310, +15V W/ETHERNET	0	NA		
19	089-4051	ICD, ATTEN UNIT, DC TO 6 GHz W/ETHERNET (+15V)	0	NA		
20	IM493	O & S MANUAL, MODEL 8310 W/ETHERNET	1	NA		

Refer to Aeroflex / Weinschel Drawing 193-7038-12, Rev. A for parts location.

Model 8310-38-F / R-EN, Attenuator Unit Assembly Replaceable Parts List (P/N 193-7038-13, Rev. A):

Find No.	Part Number	Description	Quantity Used	Reference Designator	CAGE Code	Vendor Part Number
1	193-8034-3	ASSY, BASE UNIT, W/ETHERNET (+15V)	1	NA		
2	193-8039	MOUNTING PLATE	1	NA		
3	3206T-1E	ATTEN PRGM W/SMARTSTEP INTERFACE	1	AT1		
4	7004A-1	PLANAR BULKHEAD 2.92 FEMALE	2	NA		
5	7005A-3	PLANAR CROWN, TYPE N FEMALE	2	NA		
6	068-32-4/0	COAXIAL CABLE ASSY, SMA M/M, CONFORMABLE, DC TO 18 GHZ	1	W8		B068-32-4/0
7	068-32-12/0	COAXIAL CABLE ASSY, SMA M/M, CONFORMABLE, DC TO 18 GHZ	1	W9	93459	B068-32-12/0
8	193-8041	ASSY, CABLE, CONTROLLER TO ATTENUATORS	1	W7		
11	090-301	* LABEL STD, 1.5 X .75 IN	1	NA		
12	074-761-1	HOLE PLUG 3/8 HOLE NYLON BLACK	4	NA	83330	3091
13	074-921	FEET NON-SKID	4	NA	4963	SJ-5008 BLACK
					4963	SJ-5008SP
					24803	KFT12-BLK
14	MS24693-C3	SCR FLAT HD 4-40 X 5/16 LG 100	4	NA		
15	NAS1635-04LR4	SCR PAN HD SELFLOCK 4-40 X 1/4	6	NA		
18	193-8135	WIRING DIAGRAM, ATTEN UNIT MODEL 8310, +15V W/ETHERNET	0	NA		
19	089-4051	ICD, ATTEN UNIT, W/ETHERNET (+15V)	0	NA		
20	IM493	O & S MANUAL, MODEL 8310 W/ETHERNET	1	NA		

Refer to Aeroflex / Weinschel Drawing 193-7038-13, Rev. A for parts location.

Model 8310-38-2-F / R –EN, Attenuator Unit Assembly Replaceable Parts List (P/N 193-7038-14, Rev. A):

Find No.	Part Number	Description	Quantity Used	Reference Designator	CAGE Code	Vendor Part Number
1	193-8034-3	ASSY, BASE UNIT, W/ETHERNET (+15V)	1	NA		
2	193-8039	MOUNTING PLATE	1	NA		
3	3206T-1E	ATTEN PRGM W/SMARTSTEP INTERFACE	2	AT1, AT2		
4	7004A-1	PLANAR BULKHEAD, 2.92 FEMALE	4	NA		
5	7005A-3	PLANAR CROWN, TYPE N FEMALE	4	NA		
6	068-32-4/0	COAXIAL CABLE ASSY, SMA M/M, CONFORMABLE, DC TO 18 GHZ	2	W8, W10		B068-32-4/0
7	068-32-12/0	COAXIAL CABLE ASSY, SMA M/M, CONFORMABLE, DC TO 18 GHZ	2	W9, W11	93459	B068-32-12/0
8	193-8041	ASSY, CABLE, CONTROLLER TO ATTENUATORS	1	W7		
11	090-301	* LABEL STD, 1.5 X .75 IN	1	NA		
12	074-761-1	HOLE PLUG 3/8 HOLE NYLON BLACK	4	NA	83330	3091
13	074-921	FEET NON-SKID	4	NA	4963	SJ-5008 BLACK
					4963	SJ-5008SP
					24803	KFT12-BLK
14	MS24693-C3	SCR FLAT HD 4-40 X 5/16 LG 100	4	NA		
15	NAS1635-04LR4	SCR PAN HD SELFLOCK 4-40 X 1/4	6	NA		
18	193-8135	WIRING DIAGRAM, ATTEN UNIT MODEL 8310, +15V W/ETHERNET	0	NA		
19	089-4051	ICD, ATTEN UNIT, W/ETHERNET (+15V)	0	NA		
20	IM493	O & S MANUAL, MODEL 8310 W/ETHERNET	1	NA		

Refer to Aeroflex / Weinschel Drawing 193-7038-14, Rev. A for parts location.

Model 8310-38-3-EN, Attenuator Unit Assembly Replaceable Parts List (P/N 193-7038-15, Rev. A):

Find No.	Part Number	Description	Quantity Used	Reference Designator	CAGE Code	Vendor Part Number
1	193-8034-3	ASSY, BASE UNIT, W/ETHERNET (+15V)	1	NA		
2	193-8039	MOUNTING PLATE	1	NA		
3	3206T-1E	ATTEN PRGM W/SMARTSTEP INTERFACE	3	AT1 - AT3		
4	7004A-1	PLANAR BULKHEAD, 2.92 FEMALE	6	NA		
5	7005A-3	PLANAR CROWN, TYPE N FEMALE	6	NA		
6	068-32-4/0	COAXIAL CABLE ASSY, SMA M/M, CONFORMABLE, DC TO 18 GHZ	6	W8 - W13		B068-32-4/0
8	193-8041	ASSY, CABLE, CONTROLLER TO ATTENUATORS	1	W7		
11	090-301	* LABEL STD, 1.5 X .75 IN	1	NA		
12	074-761-1	HOLE PLUG 3/8 HOLE, NYLON BLACK	2	NA	83330	3091
13	074-921	FEET NON-SKID	4	NA	4963 4963 24803	SJ-5008 BLACK SJ-5008SP KFT12-BLK
14	MS24693-C3	SCR FLAT HD 4-40 X 5/16 LG 100	6	NA		
15	NAS1635-04LR4	SCR PAN HD SELFLOCK 4-40 X 1/4	6	NA		
18	193-8135	WIRING DIAGRAM, ATTEN UNIT MODEL 8310, +15V W/ETHERNET	0	NA		
19	089-4051	ICD, ATTEN UNIT W/ETHERNET (+15V)	0	NA		
20	IM493	O & S MANUAL, MODEL 8310 W/ETHERNET	1	NA		

Refer to Aeroflex / Weinschel Drawing 193-7038-15, Rev. A for parts location.

Model 8310-38-4-T-EN, Attenuator Unit Assembly Replaceable Parts List (P/N 193-7038-16, Rev. A):

Find No.	Part Number	Description	Quantity Used	Reference Designator	CAGE Code	Vendor Part Number
1	193-8034-3	ASSY, BASE UNIT W/ETHERNET (+15V)	1	NA		
3	3206T-1E	ATTEN PRGM W/SMARTSTEP INTERFACE	4	AT1 - AT4		
4	7004A-1	PLANAR BULKHEAD, 2.92 FEMALE	8	NA		
5	7005A-3	PLANAR CROWN, TYPE N FEMALE	8	NA		
6	068-32-4/0	COAXIAL CABLE ASSY, SMA M/M, CONFORMABLE, DC TO 18 GHZ	8	W10 - W17		B068-32-4/0
8	193-8041	ASSY, CABLE, CONTROLLER TO ATTENUATORS	1	W7		
11	090-301	* LABEL STD, 1.5 X .75 IN	1	NA		
13	074-921	FEET NON-SKID	4	NA	4963 4963 24803	SJ-5008 BLACK SJ-5008SP KFT12-BLK
14	MS24693-C3	SCR FLAT HD 4-40 X 5/16 LG 100	8	NA		
15	NAS1635-04LR4	SCR PAN HD SELFLOCK 4-40 X 1/4	6	NA		
18	193-8135	WIRING DIAGRAM, ATTEN UNIT MODEL 8310, +15V W/ETHERNET	0	NA		
19	089-4051	ICD, ATTEN UNIT, DC TO 6 GHZ W/ETHERNET (+15V)	0	NA		
20	IM493	O & S MANUAL, MODEL 8310 W/ETHERNET	1	NA		

Refer to Aeroflex / Weinschel Drawing 193-7038-16, Rev. A for parts location.

Model 8310-138-FN / -RN, Attenuator Unit Assembly Replaceable Parts List (P/N 193-7138-5, Rev. A):

Find No.	Part Number	Description	Quantity Used	Reference Designator	CAGE Code	Vendor Part Number
1	193-8034-4	ASSY, BASE UNIT, W/ETHERNET (+5V)	1	NA		
2	193-8084	MOUNTING PLATE	1	NA		
3	101-2074-1	ASSY, ATTEN, PRGM, 8 CELL, 103 dB/1 dB, SMA F/F	1	AT1		
4	7004A-1	PLANAR BULKHEAD, 2.92 mm FEMALE	1	NA		
5	7005A-3	PLANAR CROWN, TYPE N FEMALE	2	NA		
6	068-32-4/0	COAXIAL CABLE ASSY, SMA M/M, CONFORMABLE, DC TO 18 GHz	1	W9		068-32-4/0
7	068-32-12/0	COAXIAL CABLE ASSY, SMA M/M, CONFORMABLE, DC - 18 GHz	1	W10	93459	B068-32-12/0
8	193-10806	ASSY, DRIVER CABLE	1	W7		
11	090-301	* LABEL STD, 1.5 X .75 IN	1	NA		
12	074-761-1	HOLE PLUG 3/8 HOLE NYLON BLACK	6	NA	83330	3091
13	074-921	FEET NON-SKID	4	NA	4963	SJ-5008 BLACK
					4963	SJ-5008SP
					24803	KFT12-BLK
14	NAS662C2LPR3	SCR, FLT HD, #2-56 X 3/16 LG, SELF-LOCK	2	NA		
15	NAS1635-04LR4	SCR PAN HD SELFLOCK 4-40 X 1/4	6	NA		
18	193-8136	WIRING DIAGRAM, ATTEN UNIT 8310 +5V W/ETHERNET	0	NA		
19	089-4066	ICD, ATTEN UNIT, MODEL 8310 (+5V) W/ETHERNET	0	NA		
20	IM493	O & S MANUAL, MODEL 8310 W/ETHERNET	1	NA		

Refer to Aeroflex / Weinschel Drawing 193-7138-5, Rev. A for parts location.

Model 8310-138-X-FN / -RN, Attenuator Unit Assembly Replaceable Parts List (P/N 193-7138-6, Rev. A):

Find No.	Part Number	Description	Quantity Used	Reference Designator	CAGE Code	Vendor Part Number
1	193-8034-4	ASSY, BASE UNIT, W/ETHERNET (+5V)	1	NA		
2	193-8084	MOUNTING PLATE	1	NA		
3	101-2074-1	ASSY, ATTN, PRGM, 8 CELL, 103 dB/1 dB, SMA F/F	2	AT1, AT2		
4	7004A-1	PLANAR BULKHEAD, 2.92 mm FEMALE	4	NA		
5	7005A-3	PLANAR CROWN, TYPE N FEMALE	4	NA		
6	068-32-4/0	COAXIAL CABLE ASSY, SMA M/M, CONFORMABLE, DC TO 18 GHz	2	W9, W11		068-32-4/0
7	068-32-12/0	COAXIAL CABLE ASSY, SMA M/M, CONFORMABLE, DC - 18 GHz	2	W10, W12	93459	B068-32-12/0
8	193-10806	ASSY, DRIVER CABLE	1	W7		
11	090-301	* LABEL STD, 1.5 X .75 IN	1	NA		
12	074-761-1	HOLE PLUG 3/8 HOLE NYLON BLACK	6	NA	83330	3091
13	074-921	FEET NON-SKID	4	NA	4963 4963 24803	SJ-5008 BLACK SJ-5008SP KFT12-BLK
14	NAS662C2LPR3	SCR, FLT HD, #2-56 X 3/16 LG, SELF-LOCK	4	NA		
15	NAS1635-04LR4	SCR PAN HD SELFLOCK 4-40 X 1/4	6	NA		
18	193-8136	WIRING DIAGRAM, ATTN UNIT 8310 +5V W/ETHERNET	0	NA		
19	089-4066	ICD, ATTN UNIT, MODEL 8310 (+5V) W/ETHERNET	0	NA		
20	IM493	O & S MANUAL, MODEL 8310 W/ETHERNET	1	NA		

Refer to Aeroflex / Weinschel Drawing 193-7403-6, Rev. A for parts location.

Model 8310-138-3-TN, Attenuator Unit Assembly Replaceable Parts List (P/N 193-7138-7, Rev. A):

Find No.	Part Number	Description	Quantity Used	Reference Designator	CAGE Code	Vendor Part Number
1	193-8034-4	ASSY, BASE UNIT, W/ETHERNET (+5V)	1	NA		
2	193-8084	MOUNTING PLATE	1	NA		
3	101-2074-1	ASSY, ATTEN, PRGM, 8 CELL, 103 dB/1 dB, SMA F/F	3	AT1 - AT3		
4	7004A-1	PLANAR BULKHEAD, 2.92 mm FEMALE	6	NA		
5	7005A-3	PLANAR CROWN, TYPE N FEMALE	6	NA		
6	068-32-4/0	COAXIAL CABLE ASSY, SMA M/M, CONFORMABLE, DC TO 18 GHz	6	W9 - W15		068-32-4/0
8	193-10806	ASSY, DRIVER CABLE	1	W7		
11	090-301	* LABEL STD, 1.5 X .75 IN	1	NA		
12	074-761-1	HOLE PLUG 3/8 HOLE NYLON BLACK	2	NA	83330	3091
13	074-921	FEET NON-SKID	4	NA	4963	SJ-5008 BLACK
					4963	SJ-5008SP
					24803	KFT12-BLK
14	NAS662C2LPR3	SCR, FLT HD, #2-56 X 3/16 LG, SELF-LOCK	6	NA		
15	NAS1635-04LR4	SCR PAN HD SELFLOCK 4-40 X 1/4	6	NA		
18	193-8136	WIRING DIAGRAM, ATTEN UNIT 8310 +5V W/ETHERNET	0	NA		
19	089-4066	ICD, ATTEN UNIT, MODEL 8310 (+5V) W/ETHERNET	0	NA		
20	IM493	O & S MANUAL, MODEL 8310 W/ETHERNET	1	NA		

Refer to Aeroflex / Weinschel Drawing 193-7403-7, Rev. A for parts location.

Model 8310-352-4-TN, Attenuator Unit Assembly Replaceable Parts List (P/N 193-7403-8, Rev. A):

Find No.	Part Number	Description	Quantity Used	Reference Designator	CAGE Code	Vendor Part Number
1	193-8034-4	ASSY, BASE UNIT, W/ETHERNET (+5V)	1	NA		
2	193-8084	MOUNTING PLATE	1	NA		
3	101-2074-1	ASSY, ATTEN, PRGM, 8 CELL, 103 dB/1 dB, SMA F/F	4	AT1 - AT4		
4	7004A-1	PLANAR BULKHEAD, 2.92 mm FEMALE	8	NA		
5	7005A-3	PLANAR CROWN, TYPE N FEMALE	8	NA		
6	068-32-4/0	COAXIAL CABLE ASSY, SMA M/M, CONFORMABLE, DC TO 18 GHz	8	W9 - W17		068-32-4/0
8	193-10806	ASSY, DRIVER CABLE	1	W7		
11	090-301	* LABEL STD, 1.5 X .75 IN	1	NA		
13	074-921	FEET NON-SKID	4	NA	4963 4963 24803	SJ-5008 BLACK SJ-5008SP KFT12-BLK
14	NAS662C2LPR3	SCR, FLT HD, #2-56 X 3/16 LG, SELF-LOCK	8	NA		
15	NAS1635-04LR4	SCR PAN HD SELFLOCK 4-40 X 1/4	8	NA		
18	193-8136	WIRING DIAGRAM, ATTEN UNIT 8310 +5V W/ETHERNET	0	NA		
19	089-4066	ICD, ATTEN UNIT, MODEL 8310 (+5V) W/ETHERNET	0	NA		
20	IM493	O & S MANUAL, MODEL 8310 W/ETHERNET	1	NA		

Refer to Aeroflex / Weinschel Drawing 193-7403-8, Rev. A for parts location.

Model 8310-352-FN / -RN, Attenuator Unit Assembly Replaceable Parts List (P/N 193-7403-5, Rev. A):

Find No.	Part Number	Description	Quantity Used	Reference Designator	CAGE Code	Vendor Part Number
1	193-8034-3	ASSY, BASE UNIT W/ETHERNET (+15V)	1	NA		
2	193-10265	MOUNTING PLATE	1	NA		
3	3408T-103	ATTEN PRGM, SMARTSTEP	1	AT1		
4	7004A-1	PLANAR BULKHEAD, 2.92 FEMALE	2	NA		
5	7005A-3	PLANAR CROWN, TYPE N FEMALE	2	NA		
6	068-32-4/0	COAXIAL CABLE ASSY, SMA M/M, CONFORMABLE, DC TO 18 GHz	1	W10		B068-32-4/0
7	068-32-12/0	COAXIAL CABLE ASSY, SMA M/M, CONFORMABLE, DC TO 18 GHz	1	W11	93459	B068-32-12/0
8	193-8127	ASSY, CABLE, DRIVER	1	W7		
11	090-301	* LABEL STD, 1.5 X .75 IN	1	NA		
12	074-761-1	HOLE PLUG 3/8 HOLE NYLON BLACK	6	NA	83330	3091
13	074-921	FEET NON-SKID	4	NA	4963	SJ-5008 BLACK
					4963	SJ-5008SP
					24803	KFT12-BLK
14	MS24693-C3	SCR FLAT HD 4-40 X 5/16 LG 100	2	NA		
15	NAS1635-04LR4	SCR PAN HD SELFLOCK 4-40 X 1/4	4	NA		
18	193-8135	WIRING DIAGRAM, ATTEN UNIT 8310 +15V W/ETHERNET	0	NA		
19	089-4065	ICD, ATTEN UNIT DC TO 6 GHz W/ETHERNET (+15V)	0	NA		
20	IM493	O & S MANUAL, MODEL 8310 W/ETHERNET	1	NA		

Refer to Aeroflex / Weinschel Drawing 193-7403-5, Rev. A for parts location.

Model 8310-352-2-FN / -RN, Attenuator Unit Assembly Replaceable Parts List (P/N 193-7403-6, Rev. A):

Find No.	Part Number	Description	Quantity Used	Reference Designator	CAGE Code	Vendor Part Number
1	193-8034-3	ASSY, BASE UNIT W/ETHERNET (+15V)	1	NA		
2	193-10265	MOUNTING PLATE	1	NA		
3	3408T-103	ATTEN PRGM, SMARTSTEP	2	AT1, AT2		
4	7004A-1	PLANAR BULKHEAD, 2.92 FEMALE	4	NA		
5	7005A-3	PLANAR CROWN, TYPE N FEMALE	4	NA		
6	068-32-4/0	COAXIAL CABLE ASSY, SMA M/M, CONFORMABLE, DC TO 18 GHZ	2	W10, W12		B068-32-4/0
7	068-32-12/0	COAXIAL CABLE ASSY, SMA M/M, CONFORMABLE, DC TO 18 GHZ	2	W11, W13	93459	B068-32-12/0
8	193-8127	ASSY, CABLE, DRIVER	1	W7		
11	090-301	* LABEL STD, 1.5 X .75 IN	1	NA		
12	074-761-1	HOLE PLUG 3/8 HOLE, NYLON BLACK	4	NA	83330	3091
13	074-921	FEET NON-SKID	4	NA	4963 4963 24803	SJ-5008 BLACK SJ-5008SP KFT12-BLK
14	MS24693-C3	SCR FLAT HD 4-40 X 5/16 LG 100	4	NA		
15	NAS1635-04LR4	SCR PAN HD SELFLOCK 4-40 X 1/4	4	NA		
18	193-8135	WIRING DIAGRAM, ATTEN UNIT MODEL 8310, +15V W/ETHERNET	0	NA		
19	089-4065	ICD, ATTEN UNIT, DC TO 6 GHZ W/ETHERNET (+15V)	0	NA		
20	IM493	O & S MANUAL, MODEL 8310 W/ETHERNET	1	NA		

Refer to Aeroflex / Weinschel Drawing 193-7403-6, Rev. A for parts location.

Model 8310-352-3-TN, Attenuator Unit Assembly Replaceable Parts List (P/N 193-7403-7, Rev. A):

Find No.	Part Number	Description	Quantity Used	Reference Designator	CAGE Code	Vendor Part Number
1	193-8034-3	ASSY, BASE UNIT W/ETHERNET (+15V)	1	NA		
2	193-10265	MOUNTING PLATE	1	NA		
3	3408T-103	ATTEN PRGM SMARTSTEP	3	AT1 - AT3		
4	7004A-1	PLANAR BULKHEAD 2.92 FEMALE	6	NA		
5	7005A-3	PLANAR CROWN, TYPE N FEMALE	6	NA		
6	068-32-4/0	COAXIAL CABLE ASSY, SMA M/M, CONFORMABLE, DC TO 18 GHz	6	W10 - W15		B068-32-4/0
8	193-8127	ASSY, CABLE, DRIVER	1	W7		
11	090-301	* LABEL STD	1	NA		
12	074-761-1	HOLE PLUG 3/8 HOLE NYLON BLACK	2	NA	83330	3091
13	074-921	FEET NON-SKID	4	NA	4963	SJ-5008 BLACK
					4963	SJ-5008SP
					24803	KFT12-BLK
14	MS24693-C3	SCR FLAT HD 4-40 X 5/16 LG 100	6	NA		
15	NAS1635-04LR4	SCR PAN HD SELFLOCK 4-40 X 1/4	4	NA		
18	193-8135	WIRING DIAGRAM, ATTEN UNIT 8310 +15V W/ETHERNET	0	NA		
19	089-4065	ICD, ATTEN UNIT, DC TO 6 GHz W/ETHERNET (+15V)	0	NA		
20	IM493	O & S MANUAL, MODEL 8310 W/ETHERNET	1	NA		

Refer to Aeroflex / Weinschel Drawing 193-7403-7, Rev. A for parts location.

Model 8310-352-4-TN, Attenuator Unit Assembly Replaceable Parts List (P/N 193-7403-8, Rev. A):

Find No.	Part Number	Description	Quantity Used	Reference Designator	CAGE Code	Vendor Part Number
1	193-8034-3	ASSY, BASE UNIT W/ETHERNET (+15V)	1	NA		
2	193-10265	MOUNTING PLATE	1	NA		
3	3408T-103	ATTEN PRGM SMARTSTEP	4	AT1 - AT4		
4	7004A-1	PLANAR BULKHEAD 2.92 FEMALE	8	NA		
5	7005A-3	PLANAR CROWN, TYPE N FEMALE	8	NA		
6	068-32-4/0	COAXIAL CABLE ASSY, SMA M/M, CONFORMABLE, DC TO 18 GHz	8	W10 - W17		B068-32-4/0
8	193-8127	ASSY, CABLE, DRIVER	1	W7		
11	090-301	* LABEL STD	1	NA		
13	074-921	FEET NON-SKID	4	NA	4963 4963 24803	SJ-5008 BLACK SJ-5008SP KFT12-BLK
14	MS24693-C3	SCR FLAT HD 4-40 X 5/16 LG 100	8	NA		
15	NAS1635-04LR4	SCR PAN HD SELFLOCK 4-40 X 1/4	4	NA		
18	193-8135	WIRING DIAGRAM, ATTEN UNIT 8310 +15V W/ETHERNET	0	NA		
19	089-4065	ICD, ATTEN UNIT, DC TO 6 GHz W/ETHERNET (+15V)	0	NA		
20	IM493	O & S MANUAL, MODEL 8310 W/ETHERNET	1	NA		

Refer to Aeroflex / Weinschel Drawing 193-7403-8, Rev. A for parts location.

Assembly, Base Unit w/Ethernet (+15V) Replaceable Parts List (P/N 193-8034-3, Rev. A):

Find No.	Part Number	Description	Quantity Used	Reference Designator	CAGE Code	Vendor Part Number
1	193-10586	ENCLOSURE, MODIFIED	1	NA		
2	193-9174	CHASSIS	1	NA		
5	193-10054-1	ASSY, CABLE, DC POWER	1	W4		
6	193-9177	ASSY CABLE PWR/INPUT TO PSU	1	W2		
7	193-8023-000	ASSY, PCB, CONTROLLER	1	A1		
10	193-8086-2	ASSY, CABLE. ATTEN TO DISTRIBUTION	1	W3		
11	193-10053-001	ASSY, PCB, 8210 XPORT ETHERNET INTF W/ D CONNECTOR	1	A5		
13	193-9190	OVERLAY, FRONT PANEL	1	NA		
15	193-8029-000	ASSY, PCB, FRONT PANEL DISPLAY	1	A3		
16	193-8028-000	ASSY, PCB, CONTROL, FRONT PANEL	1	A4		
17	001-400-15	PSU SWITCHER, +15V DC, 3.3A	1	A2	60975	GLC50-15
18	051-40	FUSE HOLDER, PWR INPUT, W/SWITCH	1	XF1	5245	PSOSXSS6B
20	193-9193	ASSY, CABLE, CONTR TO FNT PNL DISPLAY	1	W5		
22	062-184-5	CONN SCREW LOCK FEMALE	2	NA	71468	D20418-2
24	068-21	CORD PWR 3-CONDUCTOR DTCH 7.5FT 10A-125V NEMA5-15P/IEC320-C13	1	NA	16428	17250
30	055-117	SWITCH SLIDE SPDT ON-OFF-ON PNL MT 6A @ 28VDC	1	S1	9353	1103M1S3ZQE2
32	090-285	* NAMEPLATE HIGH VOLTAGE	1	NA		
33	193-9159	ASSY, CABLE, GND	1	W1		
34	052-1-1/5	FUSE 1.5 AMP, 250V	1	F1	75915	312.01.5
37	090-353	* LABEL GROUND	1	NA		
38	090-467	* LABEL, POWER INPUT	1	NA		
39	MS51957-17	SCR PAN HD 4-40 X 1/2 LG	6	NA		
40	MS15795-803	WASHER FLAT .125 ID, .250 OD	12	NA		
41	MS35338-135	WASHER LOCK #4	10	NA		
42	MS51957-14	SCR PAN HD 4-40 X .250 OD	4	NA		
43	MS24693-C3	SCR FLAT HD 4-40 X 5/16 LG 100	6	NA		
44	MS35649-244	NUT HEX #4	1	NA		
45	MS51957-15	SCR PAN HD 4-40 X 3/8 LG	4	NA		
46	MS51859-2	WASHER FLAT #4 NYLON	4	NA		
47	074-921	FEET NON-SKID	4	NA	4963 4963 24803	SJ-5008 BLACK SJ-5008SP KFT12-BLK
48	074-477-2	SPACER HH SMITH 2381	2	NA	83330	2331
50	079-147-4	WIRE #22 YELLOW TEFLON	0.5	NA		
51	079-147-5	WIRE #22 GREEN TEFLON	0.5	NA	0	A079-147-5
52	079-147-6	WIRE #22 LIGHT BLUE TEFLON	0.5	NA		
53	090-301	* LABEL STD 1.5 X .75 IN	1	NA		
56	NAS662C2R4	SCR FLAT HD 2-56 X 1/4 LG 100	2	NA		
57	NAS1635-04LR4	SCR PAN HD SELFLOCK 4-40 X 1/4	2	NA		
58	MS24693-C1	SCR FLAT HD 4-40 X 3/16 LG 100	2	NA		
59	NAS671C2	NUT HEX #2 CRES SMALL PATTERN	2	NA		
60	MS15795-802	WASHER FLAT .094 ID, .250 OD	2	NA		
61	NAS1676C2	WASHER LOCK #2	2	NA		
65	193-8135	WIRING DIAGRAM ATTEN UNIT MODEL 8310 +15V W/ETHERNET	0	NA		

Refer to Aeroflex / Weinschel Drawing 193-8034-3, Rev. A for parts location.

Assembly, Base Unit w/Ethernet (+5V) Replaceable Parts List (P/N 193-8034-4, Rev. A):

Find No.	Part Number	Description	Quantity Used	Reference Designator	CAGE Code	Vendor Part Number
1	193-10586	ENCLOSURE, MODIFIED	1	NA		
2	193-9174	CHASSIS	1	NA		
5	193-10815	ASSY, CABLE, DC POWER, +5V	1	W4		
6	193-9177	ASSY CABLE PWR/INPUT TO PSU	1	W2		
7	193-8023-003	ASSY,PCB, CONTROLLER, +5V	1	A1		
10	193-8086-2	ASSY, CABLE. ATTN TO DISTRIBUTION	1	W3		
11	193-10053-001	ASSY, PCB, 8210 XPORT ETHERNET INTF W/ D CONNECTOR	1	A5		
13	193-9190	OVERLAY, FRONT PANEL	1	NA		
15	193-8029-000	ASSY, PCB, FRONT PANEL DISPLAY	1	A3		
16	193-8028-000	ASSY, PCB, CONTROL, FRONT PANEL	1	A4		
17	001-400-5	PSU SWITCHER, +5V DC, 8A	1	A2	60975	GLC50-5
18	051-40	FUSE HOLDER, PWR INPUT, W/SWITCH	1	XF1	5245	PSOSXSS6B
20	193-9193	ASSY, CABLE, CONTROLLER TO FRONT PANEL DISPLAY	1	W5		
21	193R-8137-000	ASSY, PCB, TRANSITION, 10 PIN TO 14 PIN INTERFACE	1	A6		
22	062-184-5	CONN SCREW LOCK	2	NA	71468	D20418-2
40	MS15795-803	WASHER FLAT .125 ID, .250 OD	12	NA		
41	MS35338-135	WASHER LOCK #4	10	NA		
42	MS51957-14	SCR PAN HD 4-40 X 5/16 LG	4	NA		
43	MS24693-C3	SCR FLAT HD 4-40 X 5/16 LG 100	6	NA		
44	MS35649-244	NUT HEX #4	1	NA		
45	MS51957-15	SCR PAN HD 4-40 X 3/8 LG	4	NA		
46	MS51859-2	WASHER FLAT #4 NYLON	4	NA		
47	074-921	FEET NON-SKID	4	NA	4963 4963 24803 83330	SJ-5008 BLACK SJ-5008SP KFT12-BLK 2331
48	074-477-2	SPACER HH SMITH 2381	2	NA		
50	079-147-4	WIRE #22 YELLOW TEFLON	0.5	NA		
51	079-147-5	WIRE #22 GREEN TEFLON	0.5	NA	0	A079-147-5
52	079-147-6	WIRE #22 LIGHT BLUE TEFLON	0.5	NA		
56	NAS662C2R4	SCR FLAT HD 2-56 X 1/4 LG 100	2	NA		
57	NAS1635-04LR4	SCR PAN HD SELFLOCK 4-40 X 1/4	2	NA		
58	MS24693-C1	SCR FLAT HD 4-40 X 3/16 LG 100	2	NA		
59	NAS671C2	NUT HEX #2 CRES SMALL PATTERN	2	NA		
60	MS15795-802	WASHER FLAT .094 ID, .250 OD	2	NA		
61	NAS1676C2	WASHER LOCK #2	2	NA		
65	193-8136	WIRING DIAGRAM ATTEN UNIT MODEL 8310 +5V W/ETHERNET	0	NA		

Refer to Aeroflex / Weinschel Drawing 193-8034-4, Rev. A for parts location.

8. CONTACTING AEROFLEX / WEINSCHEL:

In the event of a malfunction, contact Aeroflex / Weinschel. An apparent malfunction of an instrument or component may be diagnosed over the phone by first contacting the Customer Service Department at Aeroflex / Weinschel. DO NOT send the instrument or component back to the factory without prior authorization. When it is necessary to return an item, state the symptoms, catalog and type number of the instrument or component, and date of original purchase. Also write the Company name and your name and phone number on a card and tape the card to the item returned. Page provides further information regarding preparation of a unit for reshipment. Contact Aeroflex / Weinschel Customer Service Department as follows:

Via mail: Aeroflex / Weinschel, Inc.
5305 Spectrum Drive
Frederick, MD 21703-7362
U.S.A.

Via Telefax: 301-846-9116

Via Phone: Call TOLL FREE 800-638-2048
Toll call # 301-846-9222

Via Website: www.aeroflex.com/weinschel

Via e-mail: weinschel-sales@aeroflex.com

9. AEROFLEX / WEINSCHEL WARRANTY:

PRODUCTS – Aeroflex / Weinschel warrants each product it manufactures to be free from defects in material and workmanship under normal use and service anywhere in the world. Aeroflex / Weinschel's only obligation under this Warranty is to repair or replace, at its plant, any product or part thereof that is returned with transportation charges prepaid to Aeroflex / Weinschel by the original purchaser within ONE YEAR from the date of shipment.

The foregoing Warranty does not apply Aeroflex / Weinschel's sole opinion to products that have been subject to improper or inadequate maintenance, unauthorized modifications, misuse, or operation outside the environmental specifications for the product.

SOFTWARE PRODUCTS – Aeroflex / Weinschel software products are supplied without representation or Warranty of any kind. Aeroflex / Weinschel, therefore, assumes no responsibility and will not accept liability (consequential or otherwise) arising from the use of program materials, disk, or tape.

The Warranty period is controlled by the Warranty document furnished with each product and begins on the date of shipment. All Warranty returns must be authorized by Aeroflex / Weinschel prior to their return.

Aeroflex / Weinschel's Quality System Certified to:



Certificate No. 94-289j

4

3

2

DWG. NO. SH1 REV.

1

REVISIONS			
REV.	DESCRIPTION	DATE	APPROVED
A	ERN 08-109	3/08	

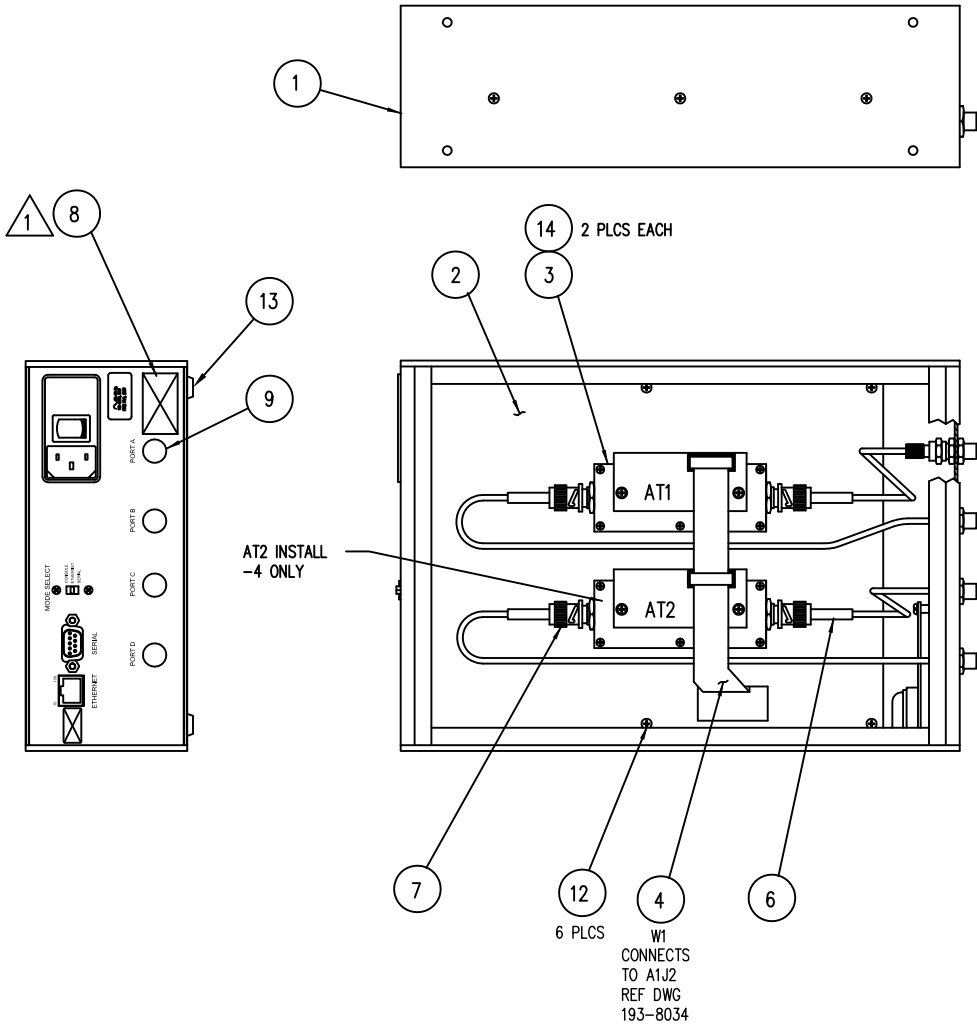

- NOTES:
- 1 PERMANENTLY MARK MODEL NO., CHANNEL NO., FREQUENCY & SERIAL NO. ON LABEL, ITEM 8. SEE DETAIL A.
 2. AFTER ASSEMBLY, CONFIGURE AND TEST.
 3. SEE CORRESPONDING PARTS LISTS FOR QUANTITIES OF ITEMS 6, 7, 9, 11 & 14.
 4. MODEL NUMBERS ENDING IN -R ARE TO BE INSTALLED OUT THE REAR OF UNIT.

Aeroflex/Weinschel
 CAGE CODE 93459 MADE IN THE USA
 MODEL: 8310-2-XN SERNO:
 FREQ: DC-1.0 GHz (75 OHM)
 CHAN: X
 ATTN: 63/1dB STEPS CE

DETAIL A
 SCALE 2:1

PROPRIETARY NOTICE
 THIS DOCUMENT IS COMMERCIAL CONFIDENTIAL AND THE INFORMATION CONTAINED THEREIN MAY NOT BE DISSEMINATED, NOR IS REPRODUCTION PERMITTED EXCEPT BY WRITTEN AUTHORIZATION.

8310-2-2-RN	193-7002-4
8310-2-2-FN	193-7002-4
8310-2-RN	193-7002-3
8310-2-FN	193-7002-3
MODEL NO.	PARTS LIST

QTY REQD	FSCM NO.	PART OR IDENTIFYING NO.	NOMENCLATURE OR DESCRIPTION	MATERIAL SPECIFICATION
PARTS LIST				
UNLESS OTHERWISE SPECIFIED DIMENSIONS ARE IN INCHES TOLERANCES ARE: FRACTIONS DECIMALS ANGLES			<p>ASSY, ATTEN UNIT, MODEL 8310-2-XN W/ETHERNET</p>	
* 1/64 * .001 * 1/2° * .005 * 1/2°				
MATERIAL		CONTRACT NO.		APPROVALS DATE DRAWN TYSON 3/08 CHECKED HOPKINS 6/09 ENGR. KNILL 6/09 ISSUED
8310-2-XN		FINISH		
NEXT ASSY		USED ON		
APPLICATION		DO NOT SCALE DRAWING		
SCALE 1/2		SHEET 1 OF 1		SIZE C FSCM NO. 93459 DWG. NO. 193-7002-3 REV. A

4

3

2

DWG. NO. SH1 REV.

1

REVISIONS			
REV.	DESCRIPTION	DATE	APPROVED
A	ERN 10-001	AH/MT 1/2010	

D

D

C

C

B

B

A

A

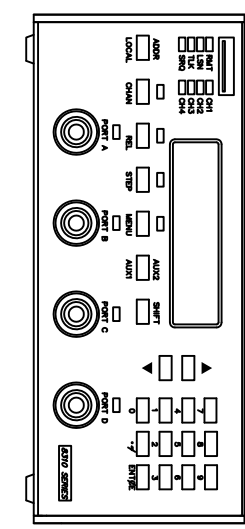
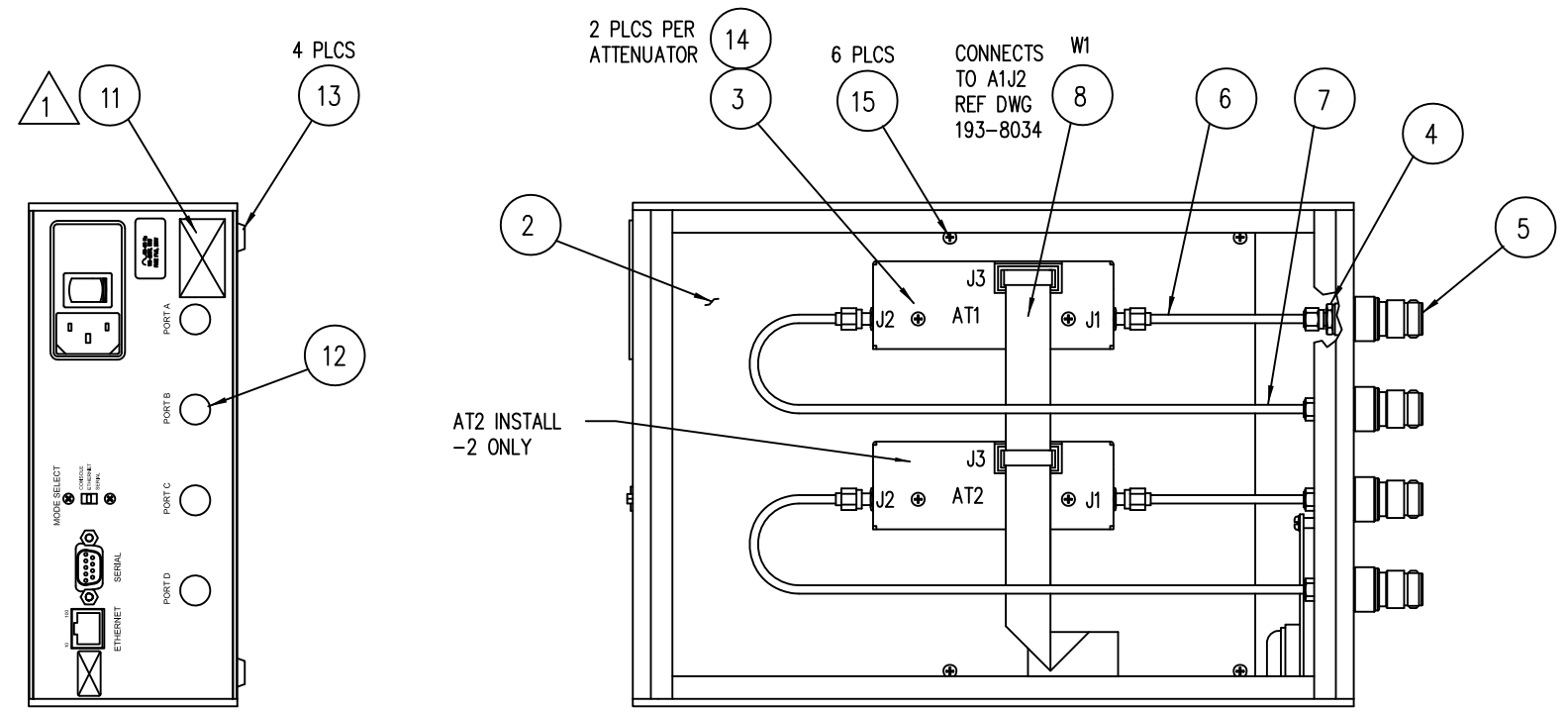

Aeroflex/Weinschel
ONE CASE ONLY MADE IN THE USA
 MODEL: 8310-35-XN SERNO:
 FREQ: DC TO X GHz
 CHAN: X
 ATTEN: 127 / 160 STEPS CE

REPLACE "X" WITH FREQ RANGE
 2 GHz FOR -1 THRU -4 ASSY
 3 GHz FOR -5 THRU -8 ASSY

DETAIL A

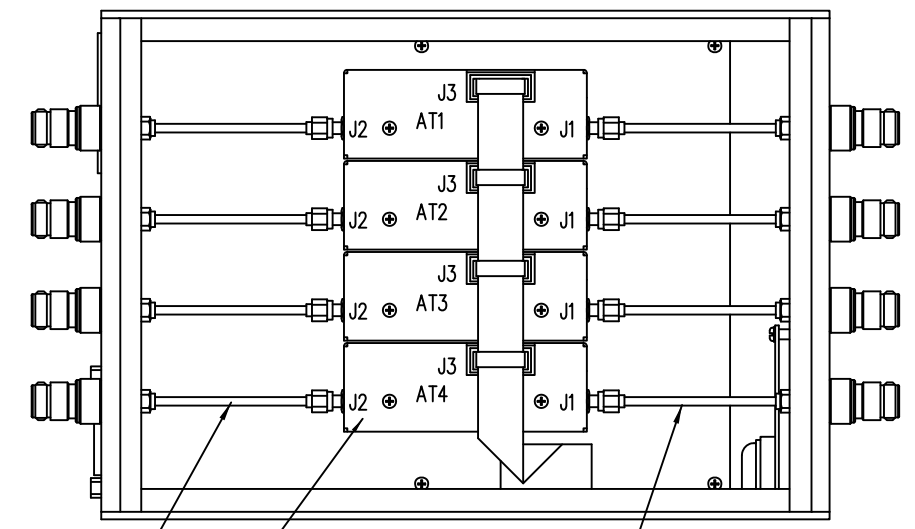

-T CONFIGURATIONS

AT4 INSTALL
 -4 ONLY

PROPRIETARY NOTICE
 THIS DOCUMENT IS COMMERCIAL CONFIDENTIAL AND THE
 INFORMATION CONTAINED THEREIN MAY NOT BE DISSEM-
 INATED, NOR IS REPRODUCTION PERMITTED EXCEPT BY
 WRITTEN AUTHORIZATION.

NOTES:

- 1 PERMANENTLY MARK MODEL NO., CHANNEL NO., FREQUENCY & SERIAL NO. ON LABEL, ITEM 11. SEE DETAIL A.
- 2 AFTER ASSEMBLY, CONFIGURE AND TEST.
- 3 SEE CORRESPONDING PARTS LISTS FOR QUANTITIES OF ITEMS 4, 5, 6, 7, 12 & 14.
- 4 MODEL NUMBERS ENDING IN -R ARE TO BE INSTALLED OUT THE REAR OF UNIT.

8310-35-4-TN	193-7035-12
8310-35-3-TN	193-7035-11
8310-35-2-RN	193-7035-10
8310-35-2-FN	193-7035-10
8310-35-RN	193-7035-9
8310-35-FN	193-7035-9
MODEL NO.	PARTS LIST

8310-35-4-T-EN	193-7035-16
8310-35-3-T-EN	193-7035-15
8310-35-2-R-EN	193-7035-14
8310-35-2-F-EN	193-7035-14
8310-35-R-EN	193-7035-13
8310-35-F-EN	193-7035-13
MODEL NO.	PARTS LIST

QTY	FSCM	PART OR	NOMENCLATURE	MATERIAL
REQD	NO.	IDENTIFYING NO.	OR DESCRIPTION	SPECIFICATION
PARTS LIST				
UNLESS OTHERWISE SPECIFIED DIMENSIONS ARE IN INCHES TOLERANCES ARE: FRACTIONS DECIMALS ANGLES $\pm 1/64$.XX ± .01 $\pm 1/2^\circ$ $.XXX \pm .003$				
MATERIAL		CONTRACT NO.		
FINISH		APPROVALS DATE		
NEXT ASSY		DRAWN M. TYSON 3/08		
USED ON		CHECKED A. HOPKINS 1/2010		
APPLICATION		ENGR. W. KNILL 1/2010		
DO NOT SCALE DRAWING		ISSUED		
		<div style="text-align: center;"> <p>ASSY, ATTEN UNIT, MODEL 8310-35-XN W/ETHERNET</p> </div>		
		SIZE C	FSCM NO. 93459	DWG. NO. 193-7035-9
		SCALE 1/2		REV. A
				SHEET 1 OF 1

4

3

2

1

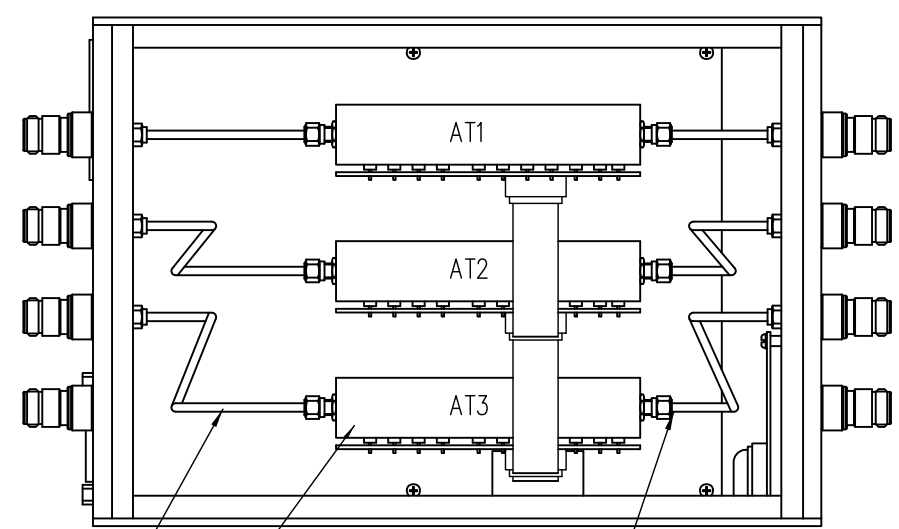
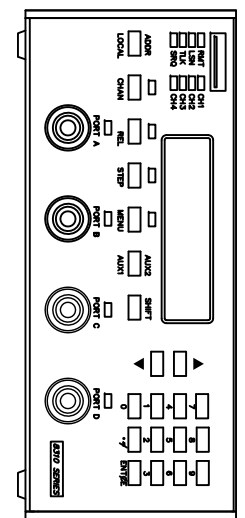
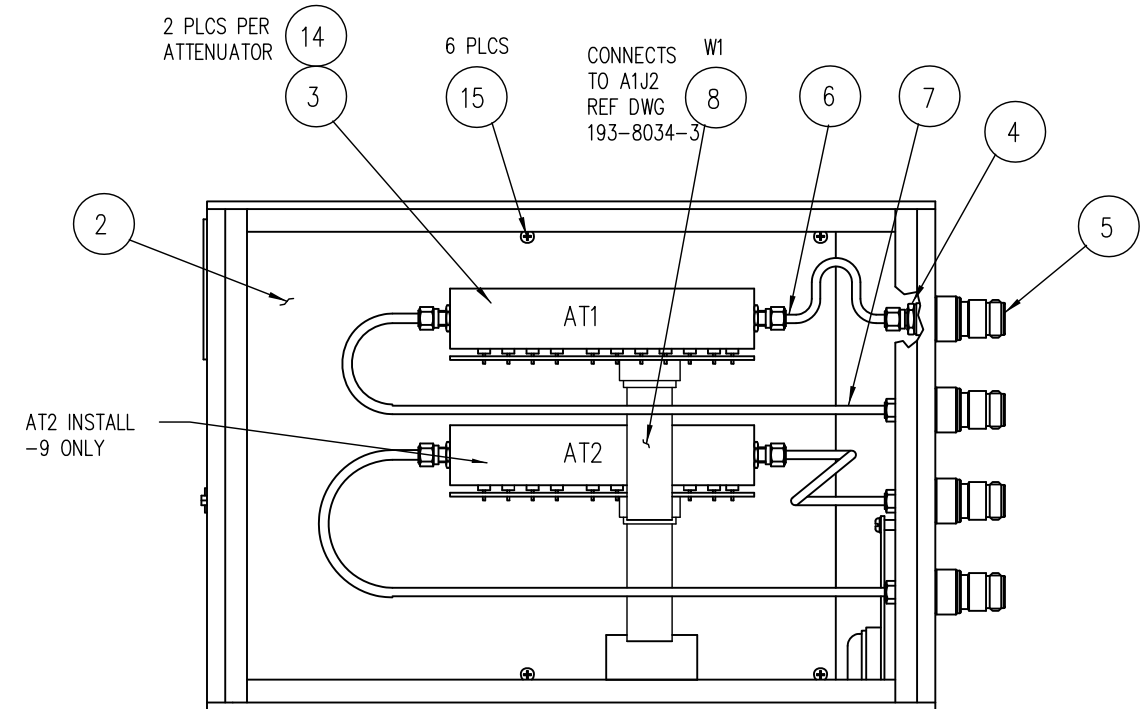
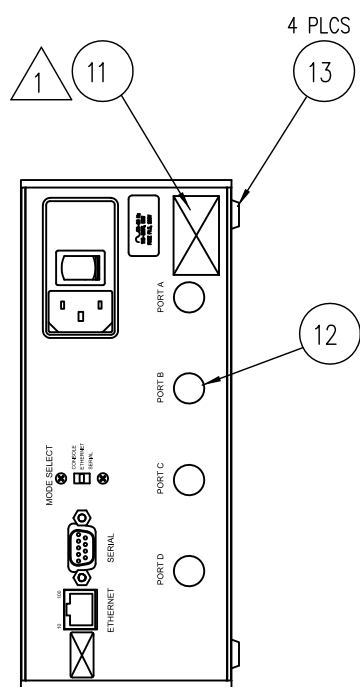
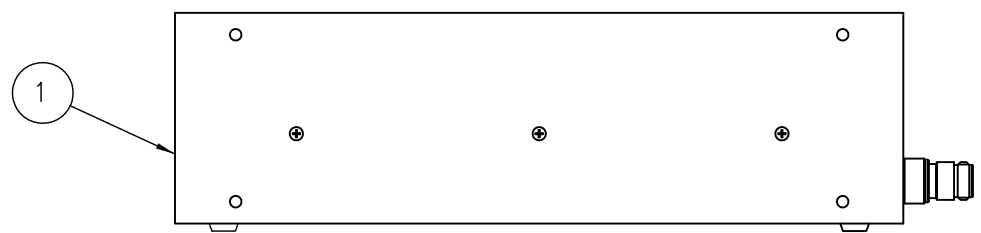

Aeroflex/Weinschel
 CAGE CODE 93459 MADE IN THE USA
 MODEL: 8310-36-XN SERNO: XXX
 FREQ: DC TO X GHz
 CHAN: X
 ATTEN: 64.5/1dB STEPS

DETAIL A

- NOTES:
- PERMANENTLY MARK MODEL NO., CHANNEL NO., FREQUENCY & SERIAL NO. ON LABEL, ITEM 11. REPLACE 'X' WITH APPROPRIATE NOMENCLATURE, SEE DETAIL A.
 - AFTER ASSEMBLY, CONFIGURE AND TEST.
 - SEE CORRESPONDING PARTS LISTS FOR QUANTITIES OF ITEMS 4, 5, 6, 7, 12 & 14.
 - MODEL NUMBERS ENDING IN -R ARE TO BE INSTALLED OUT THE REAR OF UNIT.

8310-36-3-TN	193-7036-10	8310-36-3-T-EN	193-7036-13
8310-36-2-RN	193-7036-9	8310-36-2-R-EN	193-7036-12
8310-36-2-FN	193-7036-9	8310-36-2-F-EN	193-7036-12
8310-36-RN	193-7036-8	8310-36-R-EN	193-7036-11
8310-36-FN	193-7036-8	8310-36-F-EN	193-7036-11
MODEL NO.	PARTS LIST	MODEL NO.	PARTS LIST

-T CONFIGURATIONS

AT3 INSTALL
-10 & -13 ONLY

PROPRIETARY NOTICE
 THIS DOCUMENT IS COMMERCIAL CONFIDENTIAL AND THE INFORMATION CONTAINED THEREIN MAY NOT BE DISSEMINATED, NOR IS REPRODUCTION PERMITTED EXCEPT BY WRITTEN AUTHORIZATION.

QTY REQD	FSCM NO.	PART OR IDENTIFYING NO.	NOMENCLATURE OR DESCRIPTION	MATERIAL SPECIFICATION
PARTS LIST				
UNLESS OTHERWISE SPECIFIED DIMENSIONS ARE IN INCHES TOLERANCES ARE: FRACTIONS DECIMALS ANGLES $\pm 1/64$.XX $\pm .01$.XXX $\pm .003$ $\pm 1/2^\circ$				
APPROVALS		DATE		
DRAWN M. TYSON		3/08		
CHECKED A. HOPKINS		11/09		
ENGR. W. KNILL		11/09		
ISSUED				
MATERIAL		FINISH		
NEXT ASSY		USED ON		
APPLICATION		DO NOT SCALE DRAWING		
CONTRACT NO.		AEROFLEX WEINSCHTEL		
APPROVALS		ASSY, ATTEN UNIT, MODEL 8310-36-XN W/ETHERNET		
SIZE	FSCM NO.	DWG. NO.	REV.	
C	93459	193-7036	-8 THRU -13	A
SCALE 1/2		SHEET 1 OF 1		

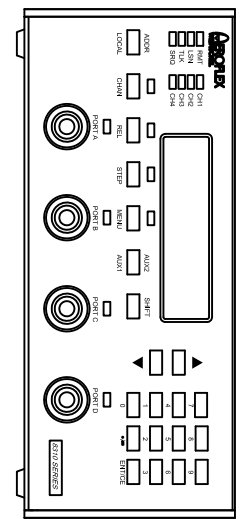
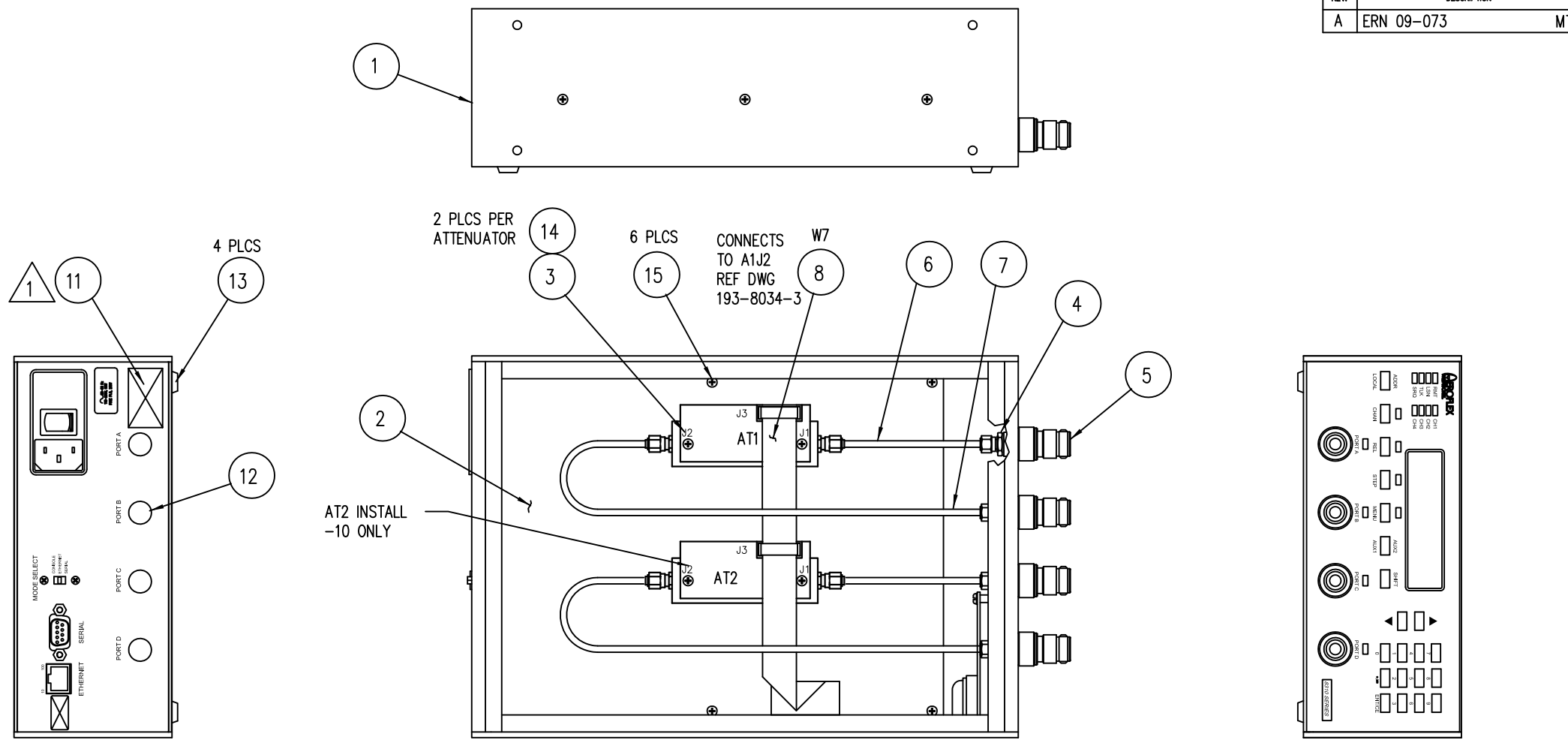

Aeroflex/Weinschel
CHG. CONTROL NUMBER MADE IN THE USA
 MODEL: 8310-38-XN SERNO:
 FREQ: DC TO X GHz
 CHAN: X
 ATTEN: 63 /100 STEPS

REPLACE "X" WITH FREQ RANGE
 2 GHz FOR -9 THRU -12 ASSY
 3 GHz FOR -13 THRU -16 ASSY

DETAIL A

- NOTES:
- PERMANENTLY MARK MODEL NO., CHANNEL NO., FREQUENCY & SERIAL NO. ON LABEL, ITEM 11. SEE DETAIL A.
 - AFTER ASSEMBLY, CONFIGURE AND TEST.
 - SEE CORRESPONDING PARTS LISTS FOR QUANTITIES OF ITEMS 4, 5, 6, 7, 12 & 14.
 - MODEL NUMBERS ENDING IN -R ARE TO BE INSTALLED OUT THE REAR OF UNIT.

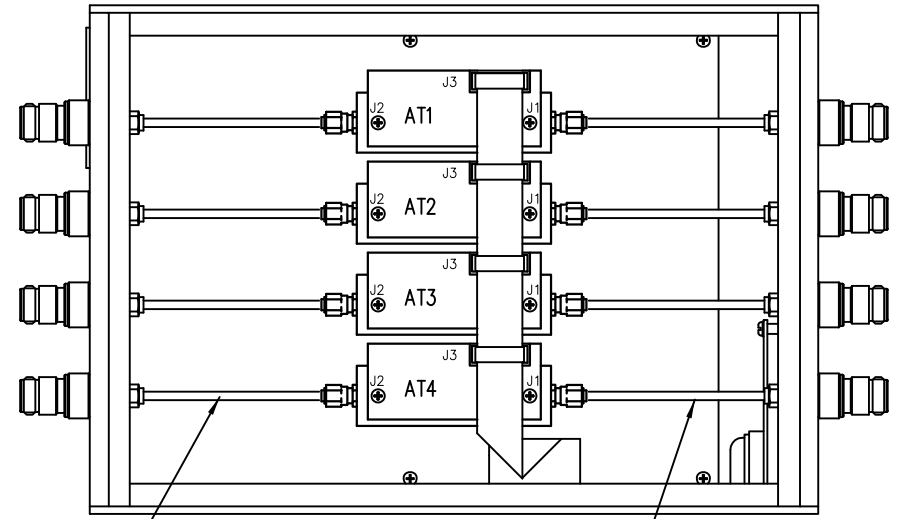

8310-38-4-T-EN	193-7038-16
8310-38-3-T-EN	193-7038-15
8310-38-2-R-EN	193-7038-14
8310-38-2-F-EN	193-7038-14
8310-38-R-EN	193-7038-13
8310-38-F-EN	193-7038-13
8310-38-4-TN	193-7038-12
8310-38-3-TN	193-7038-11
8310-38-2-RN	193-7038-10
8310-38-2-FN	193-7038-10
8310-38-RN	193-7038-9
8310-38-FN	193-7038-9
MODEL NO.	PARTS LIST

PROPRIETARY NOTICE
 THIS DOCUMENT IS COMMERCIAL CONFIDENTIAL AND THE INFORMATION CONTAINED THEREIN MAY NOT BE DISSEMINATED, NOR IS REPRODUCTION PERMITTED EXCEPT BY WRITTEN AUTHORIZATION.

QTY REQD	FSCM NO.	PART OR IDENTIFYING NO.	NOMENCLATURE OR DESCRIPTION	MATERIAL SPECIFICATION																					
PARTS LIST																									
UNLESS OTHERWISE SPECIFIED DIMENSIONS ARE IN INCHES TOLERANCES ARE: FRACTIONS DECIMALS ANGLES																									
<table border="1"> <thead> <tr> <th colspan="2">APPROVALS</th> <th>DATE</th> </tr> </thead> <tbody> <tr> <td>DRAWN</td> <td>M. TYSON</td> <td>3/08</td> </tr> <tr> <td>CHECKED</td> <td>A. HOPKINS</td> <td>3/08</td> </tr> <tr> <td>ENGR.</td> <td>W. KNILL</td> <td>3/08</td> </tr> <tr> <td>ISSUED</td> <td></td> <td></td> </tr> </tbody> </table>					APPROVALS		DATE	DRAWN	M. TYSON	3/08	CHECKED	A. HOPKINS	3/08	ENGR.	W. KNILL	3/08	ISSUED								
APPROVALS		DATE																							
DRAWN	M. TYSON	3/08																							
CHECKED	A. HOPKINS	3/08																							
ENGR.	W. KNILL	3/08																							
ISSUED																									
MATERIAL		<table border="1"> <tr> <td>CONTRACT NO.</td> <td colspan="2">AEROFLEX WEINSCHTEL</td> </tr> <tr> <td>ASSY, ATTEN UNIT, MODEL 8310-38-XN W/ETHERNET</td> <td>DWG. NO.</td> <td>193-7038-9</td> </tr> <tr> <td>FINISH</td> <td>SIZE</td> <td>C</td> </tr> <tr> <td>APPLICATION</td> <td>FSCM NO.</td> <td>93459</td> </tr> <tr> <td></td> <td>DWG. NO.</td> <td>193-7038-9</td> </tr> <tr> <td></td> <td>SCALE</td> <td>1/2</td> </tr> <tr> <td></td> <td>SHEET</td> <td>1 OF 1</td> </tr> </table>			CONTRACT NO.	AEROFLEX WEINSCHTEL		ASSY, ATTEN UNIT, MODEL 8310-38-XN W/ETHERNET	DWG. NO.	193-7038-9	FINISH	SIZE	C	APPLICATION	FSCM NO.	93459		DWG. NO.	193-7038-9		SCALE	1/2		SHEET	1 OF 1
CONTRACT NO.	AEROFLEX WEINSCHTEL																								
ASSY, ATTEN UNIT, MODEL 8310-38-XN W/ETHERNET	DWG. NO.	193-7038-9																							
FINISH	SIZE	C																							
APPLICATION	FSCM NO.	93459																							
	DWG. NO.	193-7038-9																							
	SCALE	1/2																							
	SHEET	1 OF 1																							
NEXT ASSY	USED ON	DO NOT SCALE DRAWING	REV. A																						

REVISIONS			
REV.	DESCRIPTION	DATE	APPROVED
A	ERN 08-086	3/08	

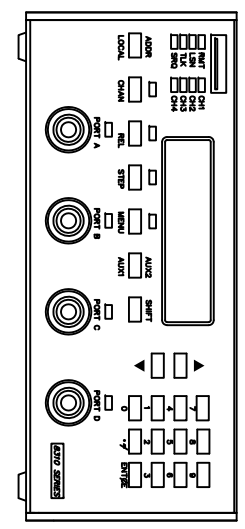
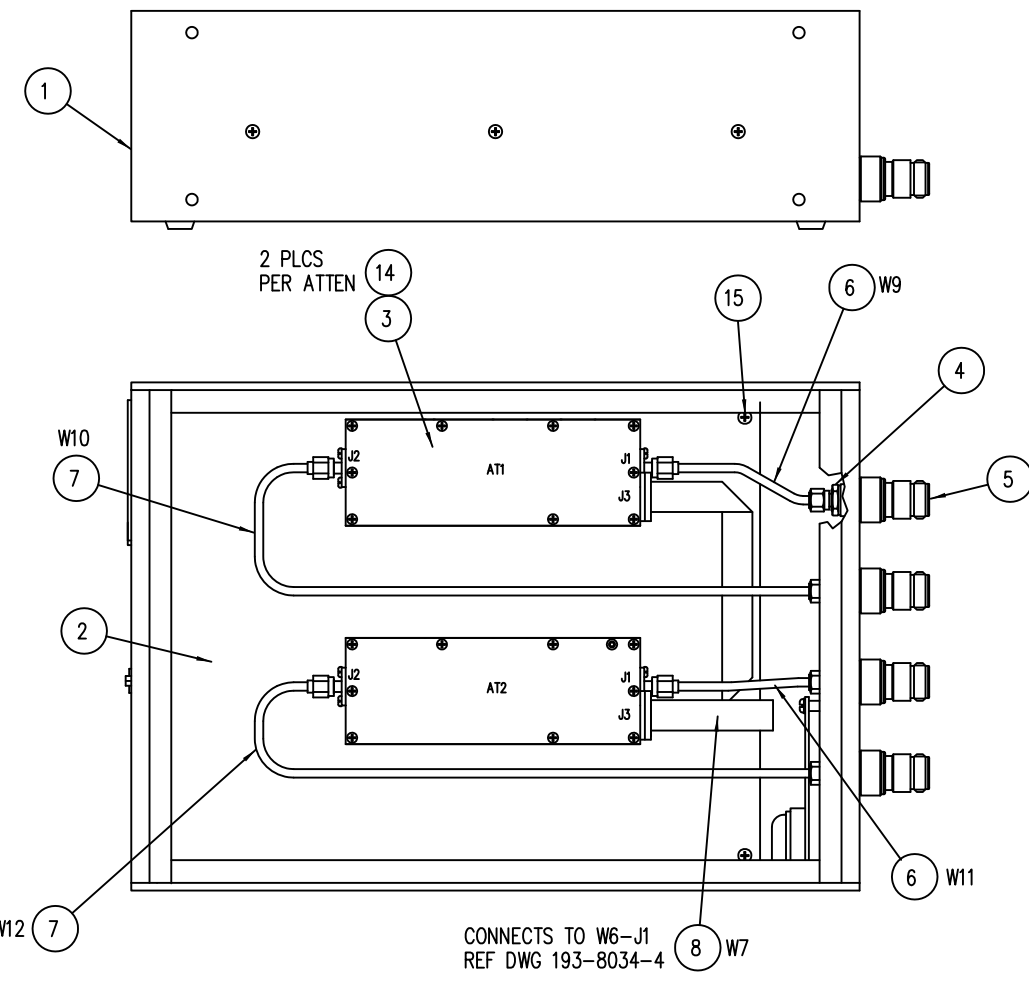
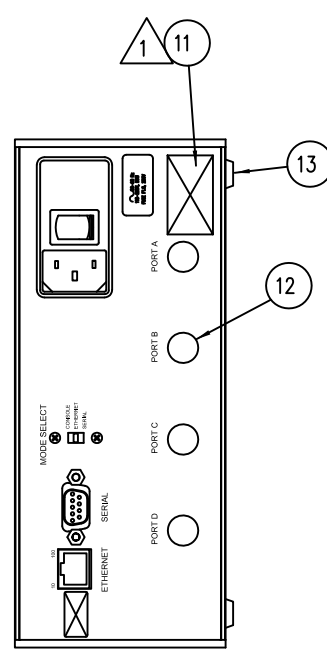

Aeroflex/Weinschel
 CAGE CODE 93459 MADE IN THE USA
 MODEL: 8310-138-XN SERNO:
 FREQ: .8 TO 3.0 GHz
 CHAN: X
 ATTEN: 103/1dB STEPS
 CE
 DETAIL "A"

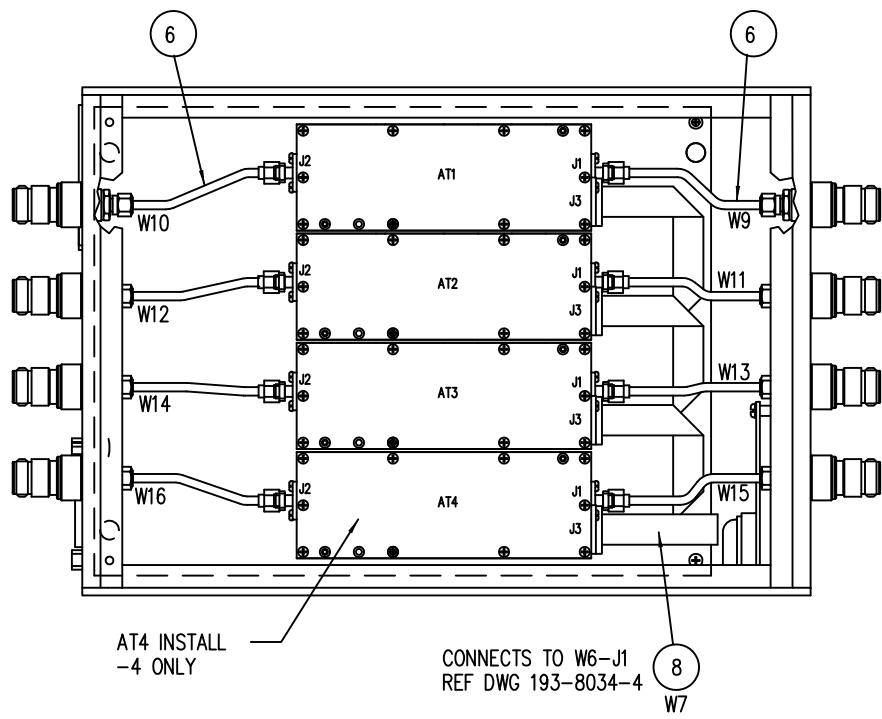

- NOTES:
- PERMANENTLY MARK MODEL NO., CHANNEL NO., FREQUENCY & SERIAL NO. ON LABEL, ITEM 11. SEE DETAIL A.
 - AFTER ASSEMBLY, CONFIGURE AND TEST.
 - SEE CORRESPONDING PARTS LISTS FOR QUANTITIES OF ITEMS 3, 4, 5, 6, 7, 12 & 14.
 - MODEL NUMBERS ENDING IN -R ARE TO BE INSTALLED OUT THE REAR OF UNIT.

8310-138-4-TN	193-7138-8
8310-138-3-TN	193-7138-7
8310-138-2-RN	193-7138-6
8310-138-2-FN	193-7138-6
8310-138-RN	193-7138-5
8310-138-FN	193-7138-5
MODEL NO.	PARTS LIST

CONNECTS TO W6-J1
 REF DWG 193-8034-4

AT4 INSTALL
 -4 ONLY

PROPRIETARY NOTICE
 THIS DOCUMENT IS COMMERCIAL CONFIDENTIAL AND THE INFORMATION CONTAINED THEREIN MAY NOT BE DISSEMINATED, NOR IS REPRODUCTION PERMITTED EXCEPT BY WRITTEN AUTHORIZATION.

QTY REQD	FSCM NO.	PART OR IDENTIFYING NO.	NOMENCLATURE OR DESCRIPTION	MATERIAL SPECIFICATION
PARTS LIST				
UNLESS OTHERWISE SPECIFIED DIMENSIONS ARE IN INCHES TOLERANCES ARE: FRACTIONS DECIMALS ANGLES ± 1/64 .XX ± .01 ± 1/2° .XXX ± .003				
CONTRACT NO.			APPROVALS	
MATERIAL			DATE	
FINISH			DRAWN TYSON	3/08
APPLICATION			CHECKED HOPKINS	6/08
DO NOT SCALE DRAWING			ENGR. KNILL	6/08
			ISSUED	
AEROFLEX WEINSCHTEL		ASSEMBLY, ATTEN UNIT		
		MODEL 8310-138-XN W/ETHERNET (+5V)		
SIZE	FSCM NO.	DWG. NO.	REV.	
C	93459	193-7138	-5 -8	A
SCALE	SHEET		1 OF 1	
1/2	1			

	8310-138-XN
NEXT ASSY	USED ON
APPLICATION	DO NOT SCALE DRAWING

REVISIONS

ZONE	REV.	DESCRIPTION	DATE	APPROVED
A	ERN 08-049		M.T.	3/08

NOTES: UNLESS OTHERWISE SPECIFIED.

- POWER CORD, ITEM 24, SUPPLIED BUT NOT SHOWN
- APPLY LOCITE, #242 ON ALL HARDWARE AS REQUIRED.
- AFTER ASSEMBLY, CONFIGURE AND TEST.
- APPLY LABEL SUPPLIED WITH ITEM 11 APPROX WHERE SHOWN.

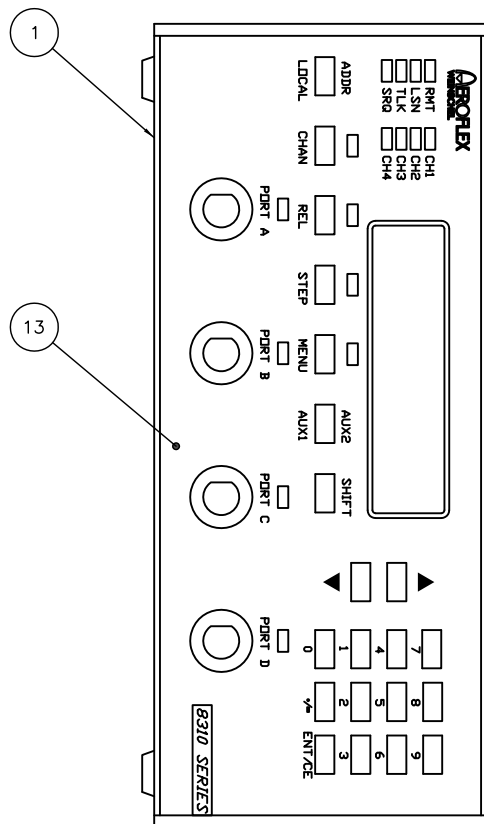
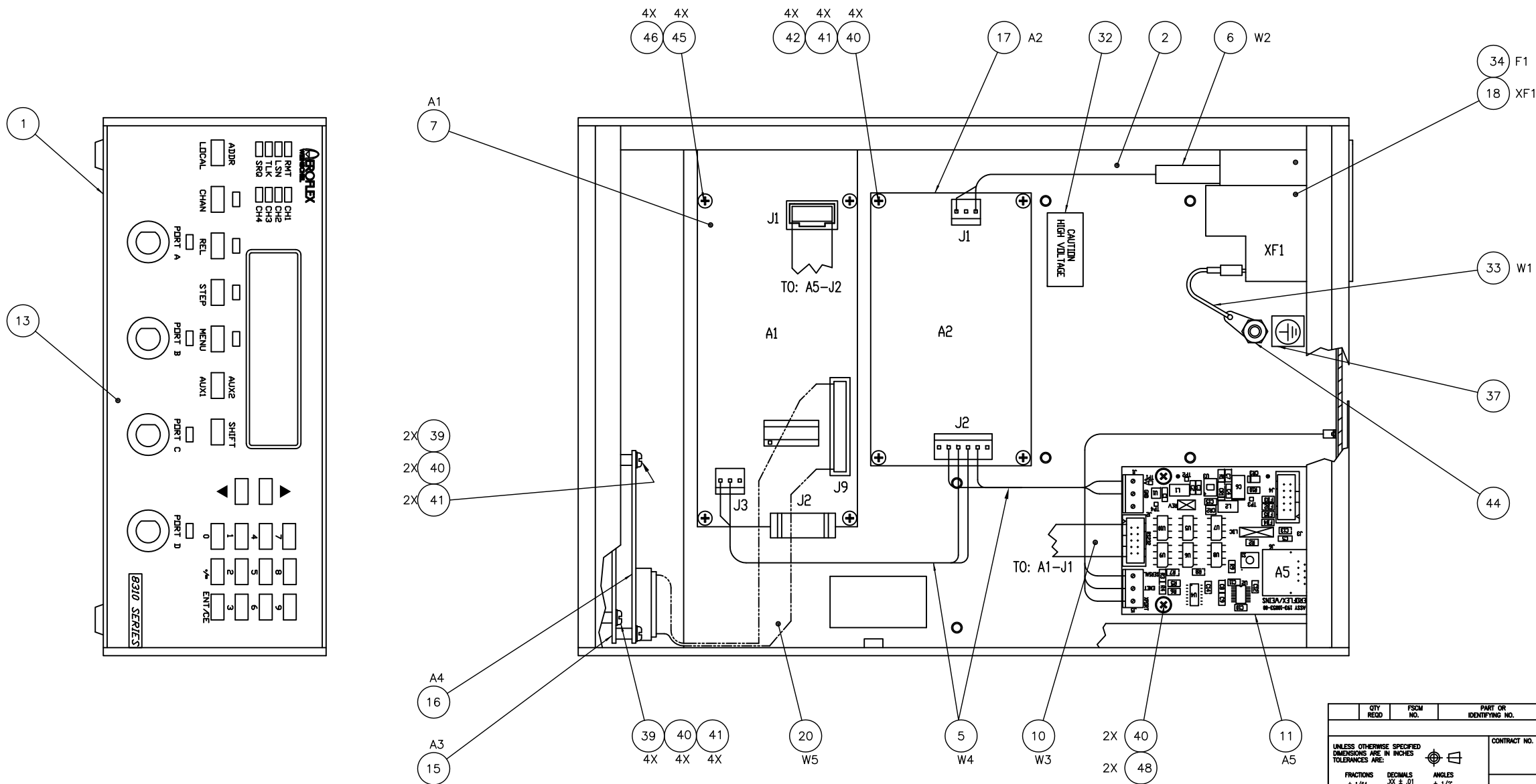
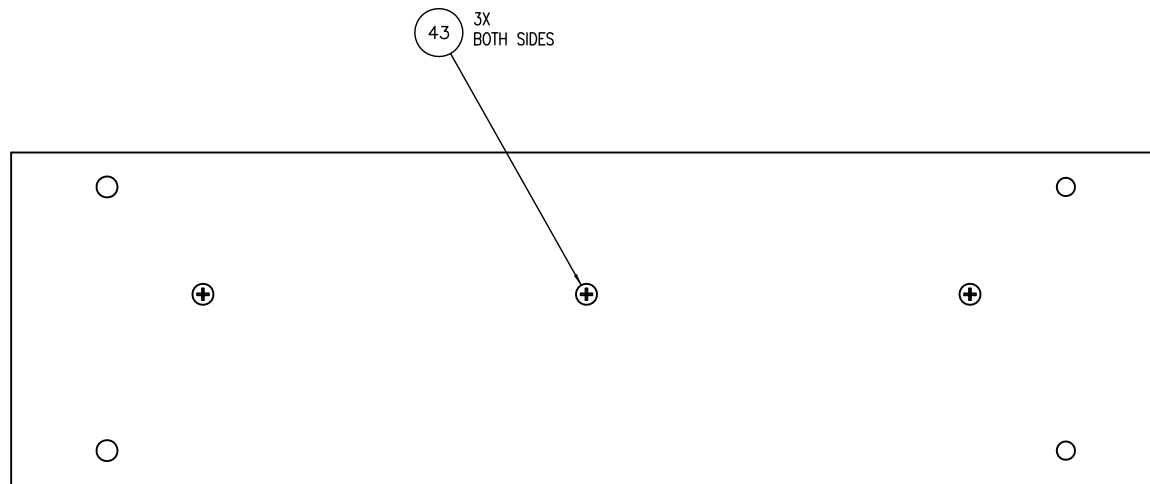

SEE PARTS LIST PL193-8034-3

QTY	NEED	PSOM NO.	PART OR IDENTIFYING NO.	NOMENCLATURE OR DESCRIPTION	MATERIAL SPECIFICATION	ZONE	ITEM NO.
PARTS LIST							
UNLESS OTHERWISE SPECIFIED DIMENSIONS ARE IN INCHES TOLERANCES ARE:				CONTRACT NO.			
FRACTIONS ± 1/64				APPROVALS			
DECIMALS .XX ± .01				DATE			
ANGLES .XXX ± .003				DRAWN M. TYSON 3/08			
MATERIAL				CHECKED A. HOPKINS 5/08			
FINISH				ENGR. B. KNILL 5/08			
NEXT ASSY				ISSUED			
USED ON				SIZE D			
APPLICATION				CAGE: 93459			
DO NOT SCALE DRAWING				DWG. NO. 193-8034-3			
				REV. A			
				SCALE 1:1			
				SHEET 1 OF 2			

PROPRIETARY NOTICE
 THIS DOCUMENT IS COMMERCIAL CONFIDENTIAL AND THE INFORMATION CONTAINED THEREIN MAY NOT BE DISSEMINATED, NOR IS REPRODUCTION PERMITTED EXCEPT BY WRITTEN AUTHORIZATION.

WIRING CHART

REF DES	FROM	TO	ITEM NO.
W1	XF1	CHASSIS GND	33
W2	XF1	A2-J1	6
W3	A1-J1	A5-J2	10
W4	A1-J3	A2-J2	5
	A2-J2-2	A5-J1-1 (+V)	
W5	A2-J2-5	A5-J1-2 (GND)	20
	A1-J9	A4-J1 FRONT PANEL	

REVISIONS			
ZONE	REV.	DESCRIPTION	DATE
		SEE SHEET 1 OF 1	

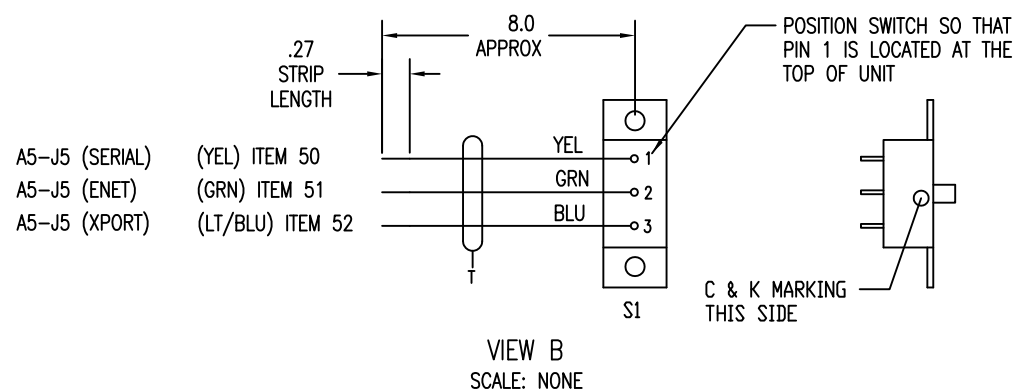
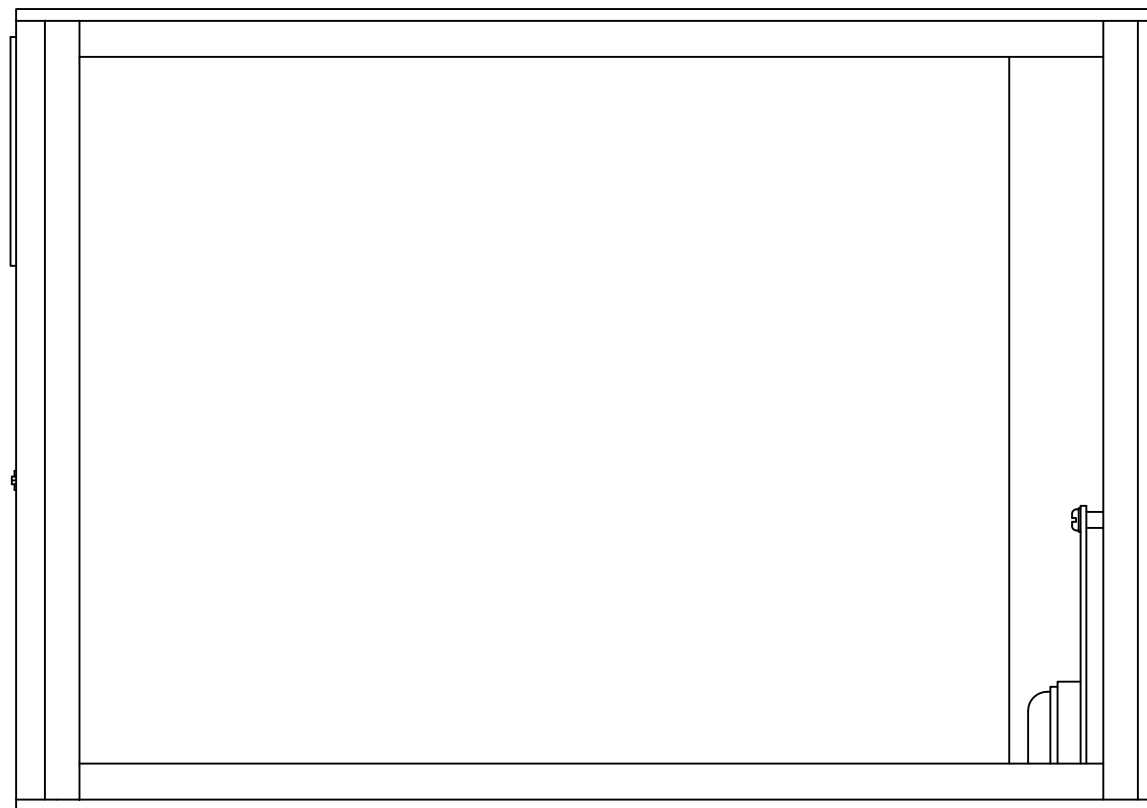
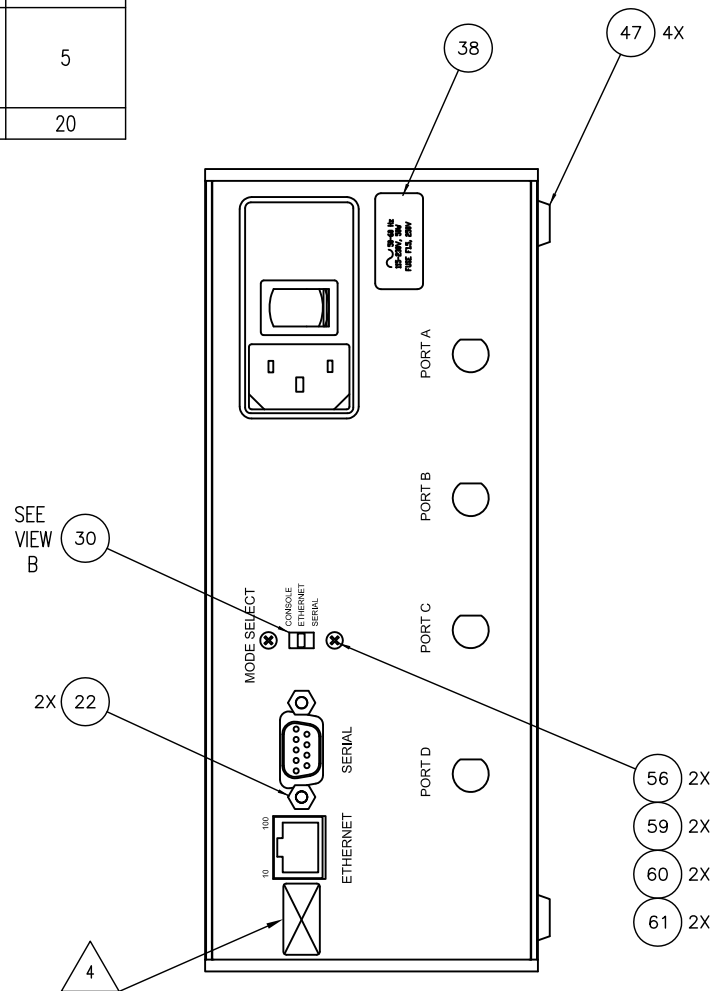

PROPRIETARY NOTICE
THIS DOCUMENT IS COMMERCIAL CONFIDENTIAL AND THE INFORMATION CONTAINED THEREIN MAY NOT BE DISSEMINATED, NOR IS REPRODUCTION PERMITTED EXCEPT BY WRITTEN AUTHORIZATION.

QTY	REQD	PSOM NO.	PART OR IDENTIFYING NO.	NOMENCLATURE OR DESCRIPTION	MATERIAL SPECIFICATION	ZONE	ITEM NO.
PARTS LIST							
UNLESS OTHERWISE SPECIFIED DIMENSIONS ARE IN INCHES TOLERANCES ARE:				CONTRACT NO.			
FRACTIONS ± 1/64				DECIMALS .XX ± .01			
ANGLES ± 1/2°				XXX ± .003			
MATERIAL				DRAWN			
FINISH				CHECKED			
NEXT ASSY				ENGR.			
USED ON				ISSUED			
APPLICATION				DO NOT SCALE DRAWING			
SIZE D		CAGE: 93459		DWG. NO. 193-8034-3		REV. A	
SCALE 1:1		SHEET 2 OF 2					

AEROFLEX WEINSCHEL
ASSY, BASE UNIT,
MODEL 8310 W/ETHERNET (+15V)

REVISIONS				
ZONE	REV.	DESCRIPTION	DATE	APPROVED
A	ERN 08-049		MT. 3/08	

NOTES:
 INSTALLED AT NEXT ASSEMBLY
 1. ATTENUATORS AT1 THRU AT4 INSTALLED AS REQUIRED
 2. CABLES W8, W9, W10, W11, W12, W13, W14, W15
 INSTALLED AS REQUIRED AND MAY BE CONNECTED
 TO EITHER FRONT OR REAR PANELS.

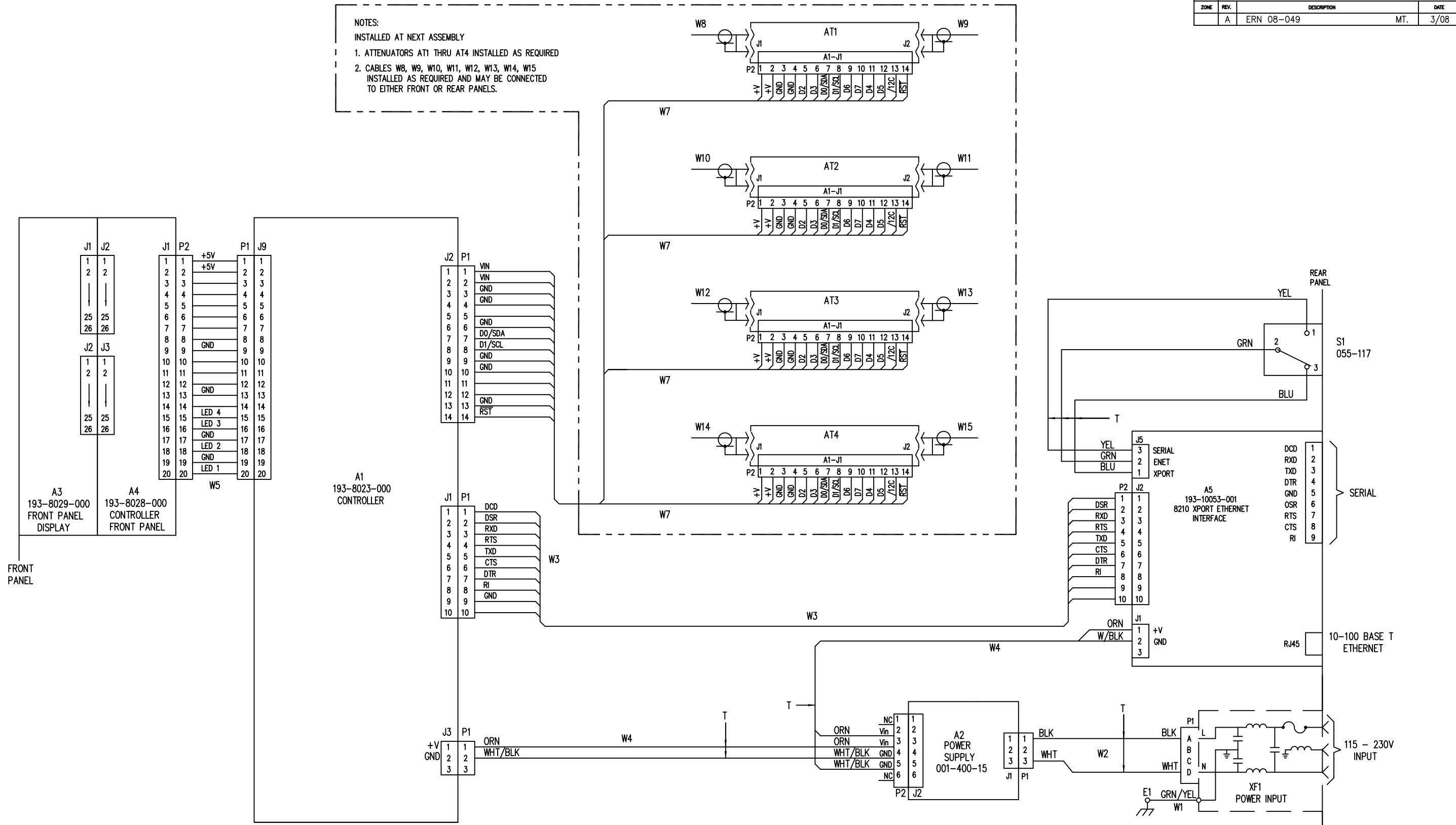

QTY	REQD	FSOM	NO.	PART OR IDENTIFYING NO.	NOMENCLATURE OR DESCRIPTION	MATERIAL SPECIFICATION	ZONE	ITEM NO.
PARTS LIST								
UNLESS OTHERWISE SPECIFIED DIMENSIONS ARE IN INCHES TOLERANCES ARE: FRACTIONS ± 1/64 DECIMALS ± .01 ANGLES ± 1/2°								
CONTRACT NO.			APPROVALS					
MATERIAL			DRAWN M. TYSON			DATE 3/08		
FINISH			CHECKED A. HOPKINS			DATE 5/08		
NEXT ASSY			ENGR. W. KNILL			DATE 5/08		
USED ON			ISSUED			SCALE 1:1		
APPLICATION			DO NOT SCALE DRAWING			SIZE D		
						CAGE: 93459		
						DWG. NO. 193-8135		
						REV. A		
						SHEET 1 OF 1		

PROPRIETARY NOTICE
 THIS DOCUMENT IS COMMERCIAL CONFIDENTIAL AND THE
 INFORMATION CONTAINED THEREIN MAY NOT BE DISSEMINATED,
 NOR IS REPRODUCTION PERMITTED EXCEPT BY WRITTEN
 AUTHORIZATION.

AEROFLEX WEINSCHEL
 WIRING DIAGRAM
 ATTENUATOR UNIT

WIRING CHART

REF DES	FROM	TO	ITEM NO.
W1	XF1	CHASSIS GND	33
W2	XF1	A2-J1	6
W3	A1-J1	A5-J2	10
W4	A1-J3 (P1)	A2-J2	5
	A2-J2(P2-2)	A5-J1-1 (+V)	
W5	A2-J2(P2-5)	A5-J1-2 (GND)	20
	A1-J9	A4-J1 FRONT PANEL	

REVISIONS			
ZONE	REV.	DESCRIPTION	DATE
		SEE SHEET 1 OF 1	

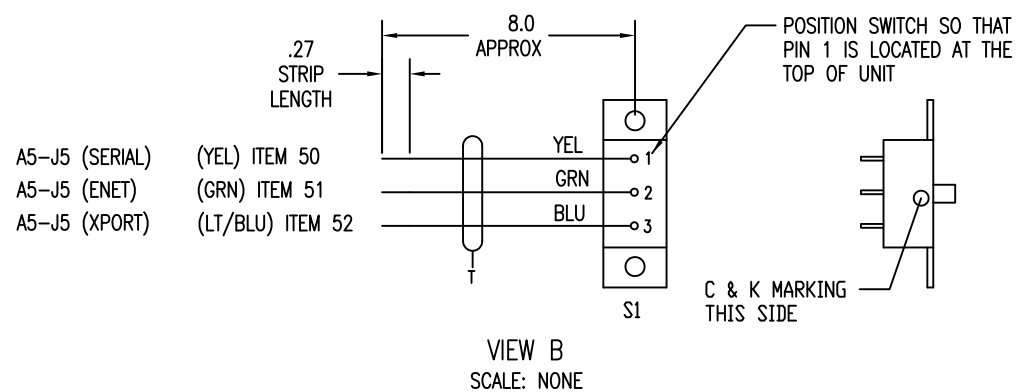
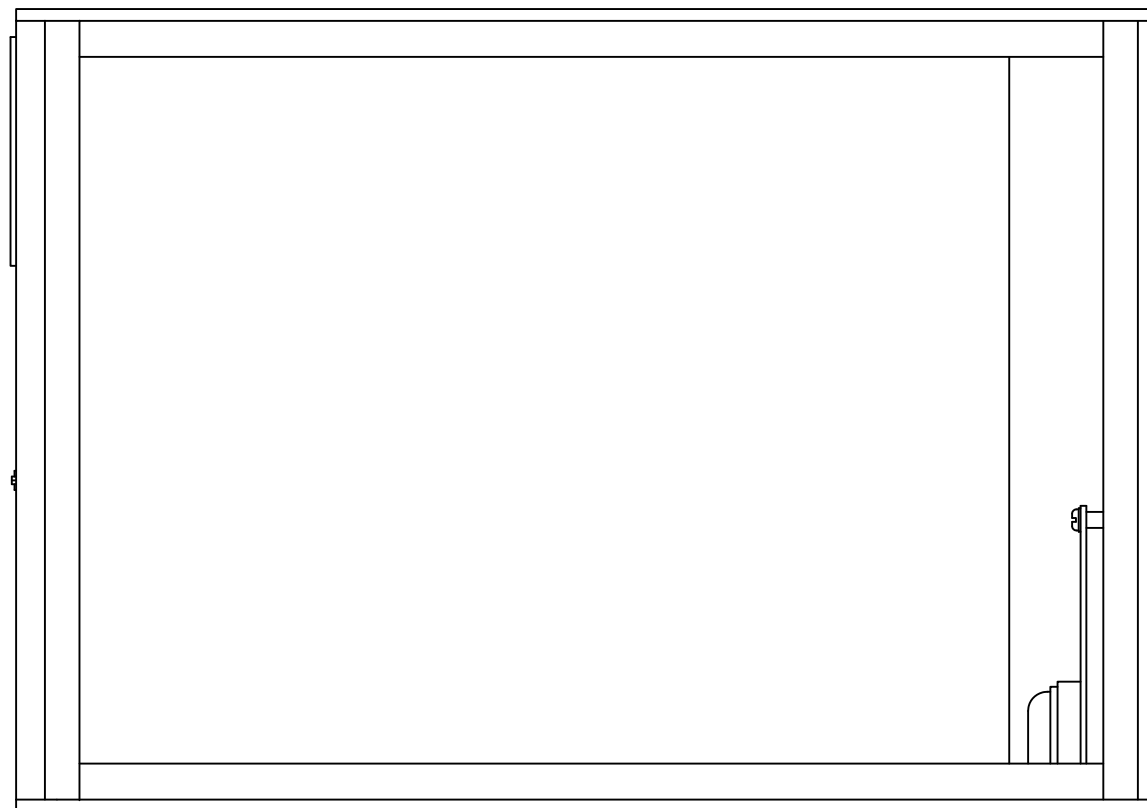
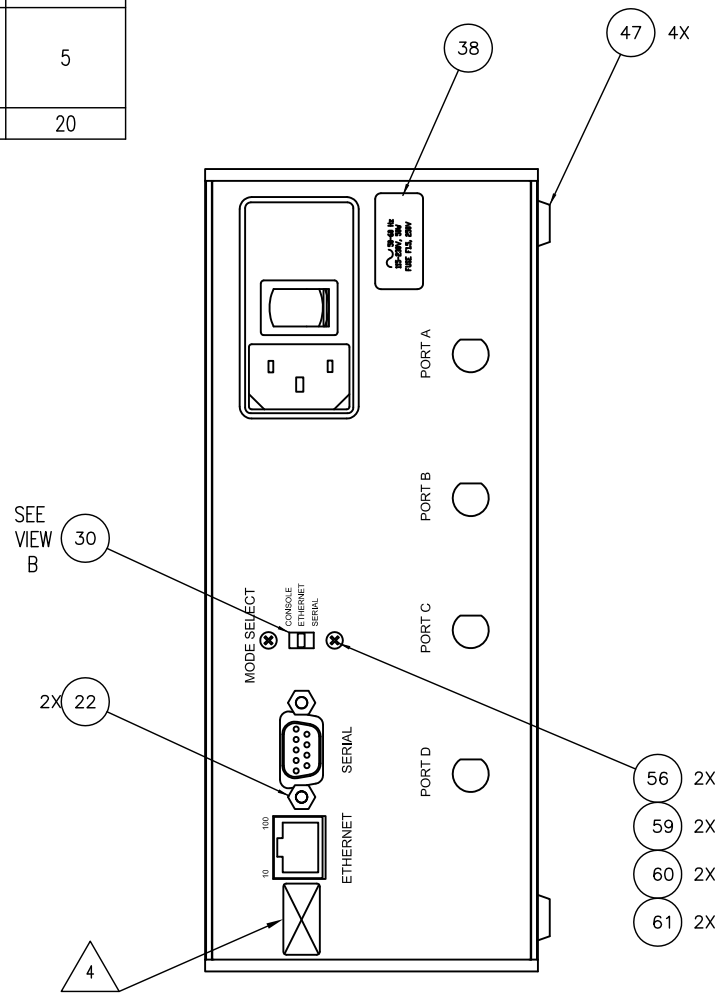

PROPRIETARY NOTICE
THIS DOCUMENT IS COMMERCIAL CONFIDENTIAL AND THE INFORMATION CONTAINED THEREIN MAY NOT BE DISSEMINATED, NOR IS REPRODUCTION PERMITTED EXCEPT BY WRITTEN AUTHORIZATION.

QTY	REQD	PSOM NO.	PART OR IDENTIFYING NO.	NOMENCLATURE OR DESCRIPTION	MATERIAL SPECIFICATION	ZONE	ITEM NO.
PARTS LIST							
UNLESS OTHERWISE SPECIFIED DIMENSIONS ARE IN INCHES TOLERANCES ARE:							
FRACCTIONS ± 1/64				DECIMALS .XX ± .01			
ANGLES ± 1/2°				.XXX ± .003			
MATERIAL				CONTRACT NO.			
FINISH				APPROVALS			
NEXT ASSY				CHECKED			
USED ON				ENGR.			
APPLICATION				ISSUED			
8310-XX-XN				DATE			
DO NOT SCALE DRAWING				SIZE D			
				CAGE: 93459			
				DWG. NO. 193-8034-4			
				REV. A			
				SCALE 1:1			
				SHEET 2 OF 2			

REVISIONS				
ZONE	REV.	DESCRIPTION	DATE	APPROVED
A	ERN 08-086		VB.	05/08

NOTES:
 INSTALLED AT NEXT ASSEMBLY
 1. ATTENUATORS AT1 THRU AT4 INSTALLED AS REQUIRED
 2. CABLES W9, W10, W11, W12, W13, W14, W15, W16
 INSTALLED AS REQUIRED AND MAY BE CONNECTED
 TO EITHER FRONT OR REAR PANELS.

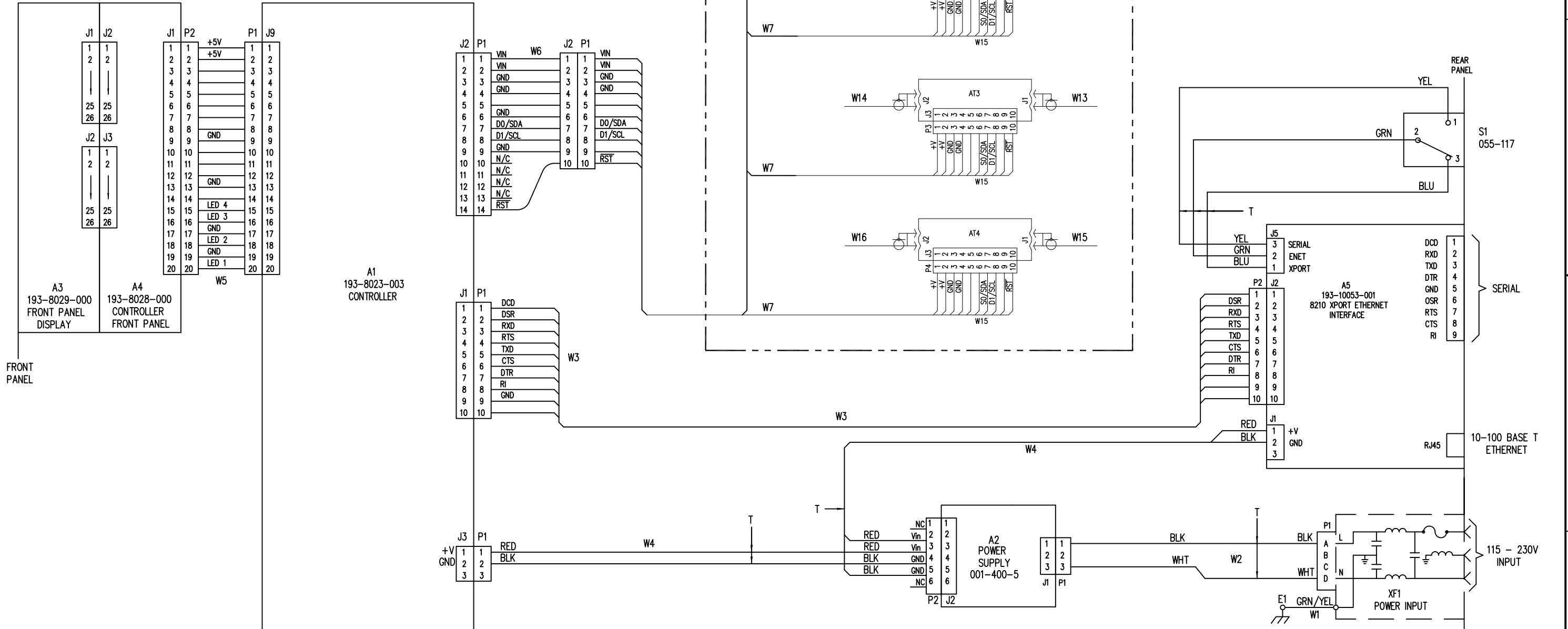

PROPRIETARY NOTICE
 THIS DOCUMENT IS COMMERCIAL CONFIDENTIAL AND THE
 INFORMATION CONTAINED THEREIN MAY NOT BE DISSEMINATED,
 NOR IS REPRODUCTION PERMITTED EXCEPT BY WRITTEN
 AUTHORIZATION.

QTY	REQD	FSQM	NO.	PART OR IDENTIFYING NO.	NOMENCLATURE OR DESCRIPTION	MATERIAL SPECIFICATION	ZONE	ITEM NO.
PARTS LIST								
UNLESS OTHERWISE SPECIFIED DIMENSIONS ARE IN INCHES TOLERANCES ARE:								
CONTRACT NO.								
APPROVALS		DATE			WIRING DIAGRAM ATTENUATOR UNIT			
DRAWN V. BETSIS		05/08			REV. A			
CHECKED A. HOPKINS		05/08			SIZE D			
ENGR. W. KNILL		05/08			CAGE: 93459		DWG. NO. 193-8136	
ISSUED		DO NOT SCALE DRAWING			SCALE 1:1		SHEET 1 OF 1	

DWG. NO.		1	
REVISIONS			
ZONE	REV.	DESCRIPTION	DATE
A	ERN 09-073	MT/AH	4/09

NOTES:
1. ALL DIMENSIONS GIVEN IN MM (INCHES)

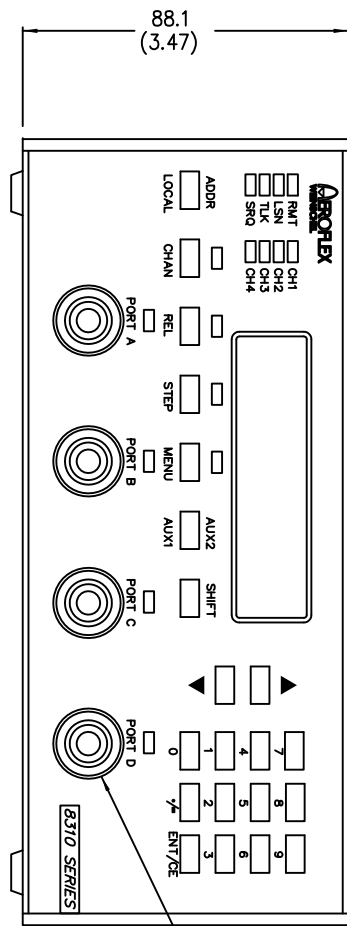

CONNECTOR, TYPE N FEMALE PLANAR CROWN

TYP FRONT OR REAR
29.2 (1.15)

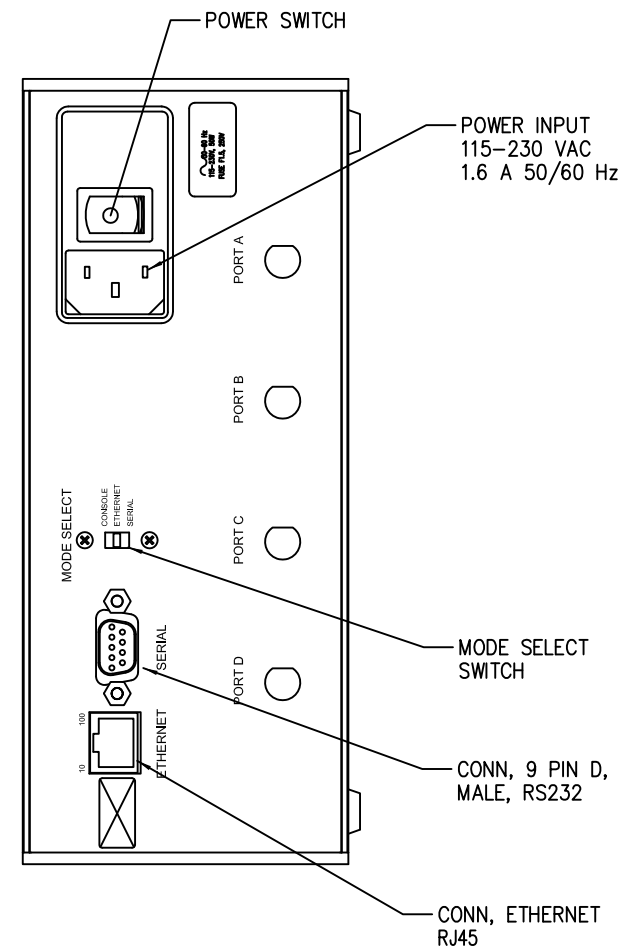
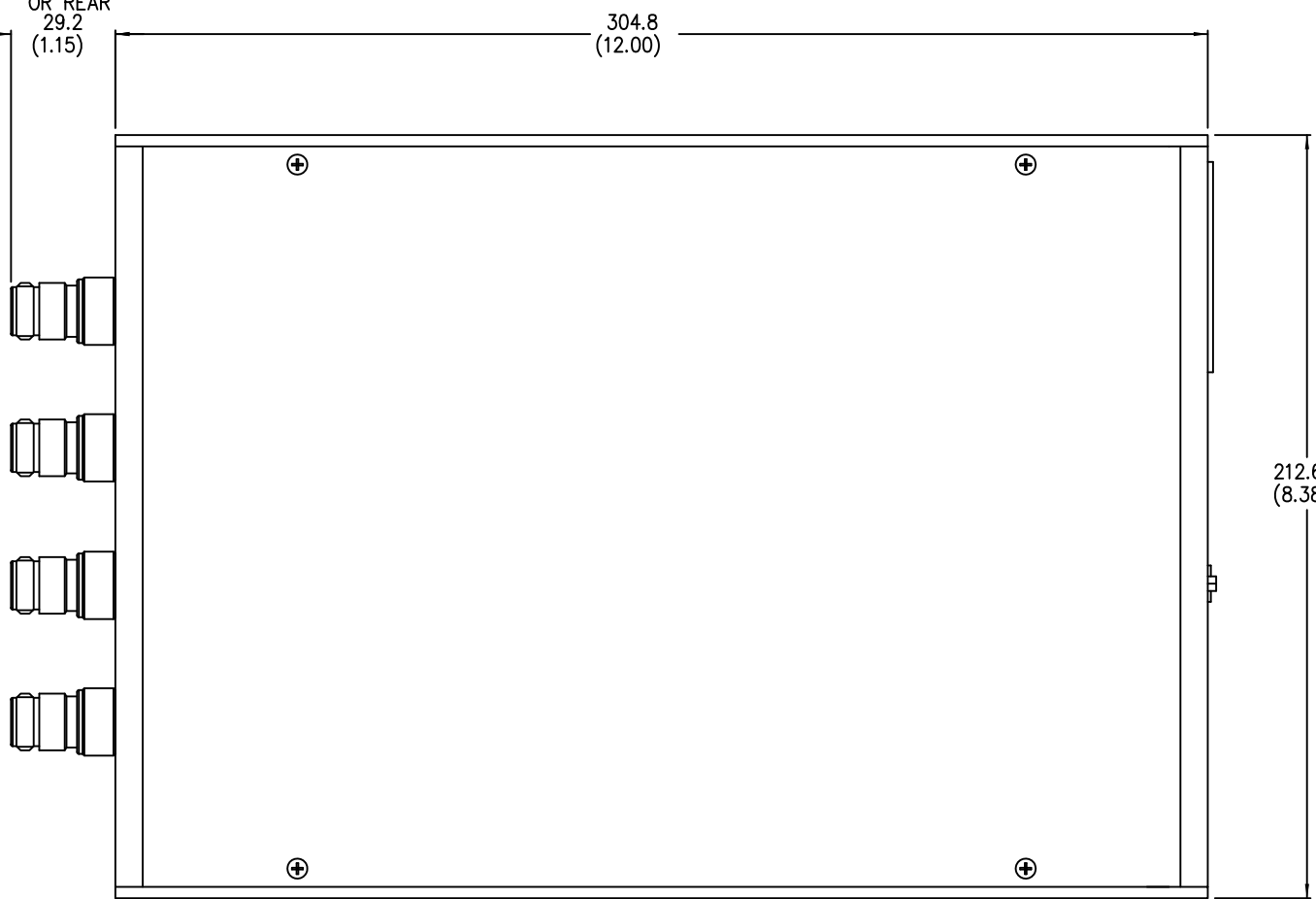

INTERFACE CONTROL DRAWING

QTY REQD	FSCM NO.	PART OR IDENTIFYING NO.	NOMENCLATURE OR DESCRIPTION	MATERIAL SPECIFICATION	ZONE	ITEM NO.	
PARTS LIST							
UNLESS OTHERWISE SPECIFIED DIMENSIONS ARE IN INCHES TOLERANCES ARE FRACTIONS DECIMALS ANGLES		CONTRACT NO.		<p>ICD, ATTENUATOR UNIT W/ENET (+15V)</p>			
3/16 ± .015 1/32 ± .010 .001 ± .005 1/4° ± 15'		APPROVALS	DATE				
MATERIAL		DRAWN	M. TYSON				3/08
FINISH		CHECKED	A. HOPKINS				4/09
NEXT ASSY	USED ON	ENGR.	B. KNILL	4/09	SIZE	D	
APPLICATION		DO NOT SCALE DRAWING		FSCM NO.	DWG. NO.	REV.	
				93459	089-4051	A	
				SCALE	1/1	SHEET 1 OF 2	

PROPRIETARY NOTICE
THIS DOCUMENT IS COMMERCIAL CONFIDENTIAL AND THE INFORMATION CONTAINED THEREIN MAY NOT BE DISSEMINATED, NOR IS REPRODUCTION PERMITTED EXCEPT BY WRITTEN AUTHORIZATION.

DWG. NO.		1	
REVISIONS			
ZONE	REV.	DESCRIPTION	DATE
		SEE SHEET 1	

MODEL NO.	ATTENUATOR VALVE	FREQUENCY RANGE	INSERTION LOSS	SWR	NO. OF CHANNELS	ATTENUATOR TYPE (1)	CONNECTOR TYPE	CONNECTOR LOCATION
8310-35-FN	127/1	dC-2GHz	6.0 dB MAX	1.4 MAX	1	3200T-1	N/F	FRONT
8310-35-RN	127/1	dC-2GHz	6.0 dB MAX	1.4 MAX	1	3200T-1	N/F	REAR
8310-35-2-FN	127/1	dC-2GHz	6.0 dB MAX	1.4 MAX	2	3200T-1	N/F	FRONT
8310-35-2-RN	127/1	dC-2GHz	6.0 dB MAX	1.4 MAX	2	3200T-1	N/F	REAR
8310-35-3-TN	127/1	dC-2GHz	6.0 dB MAX	1.4 MAX	3	3200T-1	N/F	FRONT TO REAR
8310-35-4-TN	127/1	dC-2GHz	6.0 dB MAX	1.4 MAX	4	3200T-1	N/F	FRONT TO REAR
8310-35-F-EN	127/1	dC-3GHz	6.0 dB MAX	1.5 MAX	1	3200T-1E	N/F	FRONT
8310-35-R-EN	127/1	dC-3GHz	6.0 dB MAX	1.5 MAX	1	3200T-1E	N/F	REAR
8310-35-2-F-EN	127/1	dC-3GHz	6.0 dB MAX	1.5 MAX	2	3200T-1E	N/F	FRONT
8310-35-2-R-EN	127/1	dC-3GHz	6.0 dB MAX	1.5 MAX	2	3200T-1E	N/F	REAR
8310-35-3-T-EN	127/1	dC-3GHz	6.0 dB MAX	1.5 MAX	3	3200T-1E	N/F	FRONT TO REAR
8310-35-4-T-EN	127/1	dC-3GHz	6.0 dB MAX	1.5 MAX	4	3200T-1E	N/F	FRONT TO REAR
8310-36-FN	64.5/0.1	dC-2GHz	8.0 dB MAX	1.4 MAX	1	3209T-1	N/F	FRONT
8310-36-RN	64.5/0.1	dC-2GHz	8.0 dB MAX	1.4 MAX	1	3209T-1	N/F	REAR
8310-36-2-FN	64.5/0.1	dC-2GHz	8.0 dB MAX	1.4 MAX	2	3209T-1	N/F	FRONT
8310-36-2-RN	64.5/0.1	dC-2GHz	8.0 dB MAX	1.4 MAX	2	3209T-1	N/F	REAR
8310-36-3-TN	64.5/0.1	dC-2GHz	8.0 dB MAX	1.4 MAX	3	3209T-1	N/F	FRONT TO REAR
8310-36-F-EN	64.5/0.1	dC-3GHz	8.0 dB MAX	1.4 MAX	1	3209T-1-E	N/F	FRONT
8310-36-R-EN	64.5/0.1	dC-3GHz	8.0 dB MAX	1.4 MAX	1	3209T-1-E	N/F	REAR
8310-36-2-F-EN	64.5/0.1	dC-3GHz	8.0 dB MAX	1.4 MAX	2	3209T-1-E	N/F	FRONT
8310-36-2-R-EN	64.5/0.1	dC-3GHz	8.0 dB MAX	1.4 MAX	2	3209T-1-E	N/F	REAR
8310-36-3-T-EN	64.5/0.1	dC-3GHz	8.0 dB MAX	1.4 MAX	3	3209T-1-E	N/F	FRONT TO REAR
8310-37-FN	63.75/0.25	dC-2GHz	6.0 dB MAX	1.4 MAX	1	3200T-2	N/F	FRONT
8310-37-RN	63.75/0.25	dC-2GHz	6.0 dB MAX	1.4 MAX	1	3200T-2	N/F	REAR
8310-37-2-FN	63.75/0.25	dC-2GHz	6.0 dB MAX	1.4 MAX	2	3200T-2	N/F	FRONT
8310-37-2-RN	63.75/0.25	dC-2GHz	6.0 dB MAX	1.4 MAX	2	3200T-2	N/F	REAR
8310-37-3-TN	63.75/0.25	dC-2GHz	6.0 dB MAX	1.4 MAX	3	3200T-2	N/F	FRONT TO REAR
8310-37-4-TN	63.75/0.25	dC-2GHz	6.0 dB MAX	1.4 MAX	4	3200T-2	N/F	FRONT TO REAR
8310-38-FN	63/1	dC-2GHz	5.25 dB MAX	1.4 MAX	1	3206T-1	N/F	FRONT
8310-38-RN	63/1	dC-2GHz	5.25 dB MAX	1.4 MAX	1	3206T-1	N/F	REAR
8310-38-2-FN	63/1	dC-2GHz	5.25 dB MAX	1.4 MAX	2	3206T-1	N/F	FRONT
8310-38-2-RN	63/1	dC-2GHz	5.25 dB MAX	1.4 MAX	2	3206T-1	N/F	REAR
8310-38-3-TN	63/1	dC-2GHz	5.25 dB MAX	1.4 MAX	3	3206T-1	N/F	FRONT TO REAR
8310-38-4-TN	63/1	dC-2GHz	5.25 dB MAX	1.4 MAX	4	3206T-1	N/F	FRONT TO REAR
8310-38-F-EN	63/1	dC-3GHz	5.25dB MAX	1.4 MAX	1	3206T-1E	N/F	FRONT
8310-38-R-EN	63/1	dC-3GHz	5.25dB MAX	1.4 MAX	1	3206T-1E	N/F	REAR
8310-38-2-F-EN	63/1	dC-3GHz	5.25dB MAX	1.4 MAX	2	3206T-1E	N/F	FRONT
8310-38-2-R-EN	63/1	dC-3GHz	5.25dB MAX	1.4 MAX	2	3206T-1E	N/F	REAR
8310-38-3-T-EN	63/1	dC-3GHz	5.25dB MAX	1.4 MAX	3	3206T-1E	N/F	FRONT TO REAR
8310-38-4-T-EN	63/1	dC-3GHz	5.25dB MAX	1.4 MAX	4	3206T-1E	N/F	FRONT TO REAR

(1) SEE ATTENUATOR INTERFACE CONTROL DRAWING FOR RF SPECIFICATIONS

PROPRIETARY NOTICE
 THIS DOCUMENT IS COMMERCIAL CONFIDENTIAL AND THE INFORMATION CONTAINED THEREIN MAY NOT BE DISSEMINATED, NOR IS REPRODUCTION PERMITTED EXCEPT BY WRITTEN AUTHORIZATION.

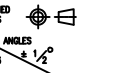
QTY	REQD	FROM NO.	PART OR IDENTIFYING NO.	NUMERICAL OR DESCRIPTION	MATERIAL SPECIFICATION	ZONE	ITEM NO.
PARTS LIST							
UNLESS OTHERWISE SPECIFIED DIMENSIONS ARE IN INCHES TOLERANCES ARE FRACTIONS DECIMALS ANGLES							
				CONTRACT NO. _____ APPROVALS _____ DATE _____ DRAWN _____ CHECKED _____ ENGR. _____ ISSUED _____			
MATERIAL		FINISH		ICD, ATTENUATOR UNIT W/ENET (+15V)		SIZE D FSCM NO. 93459 DWG. NO. 089-4051 SCALE 1/1	
NEXT ASSY		USED ON		APPLICATION		SHEET 2 OF 2 REV. A	
DO NOT SCALE DRAWING							

REVISIONS			
REV.	DESCRIPTION	DATE	APPROVED
A	ERN 09-109	6/09	

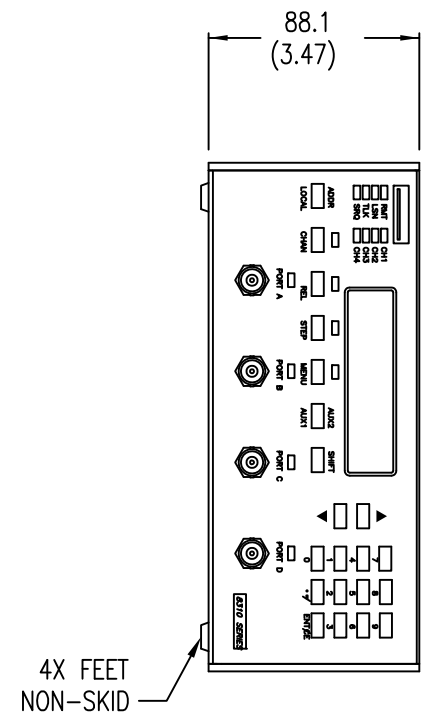

DIM "A"
TYP FRONT
OR REAR

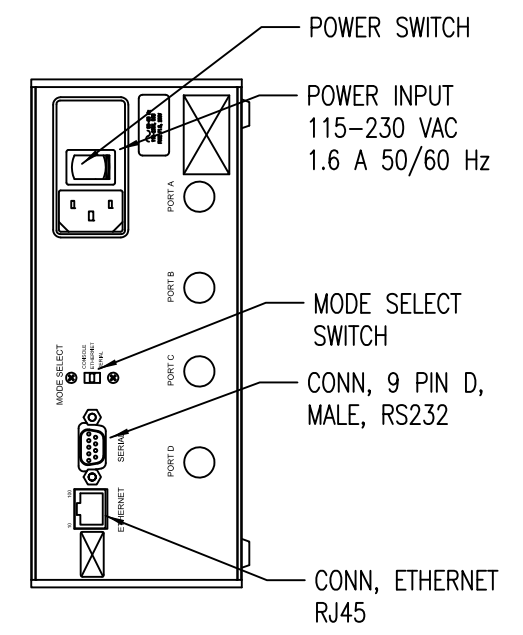
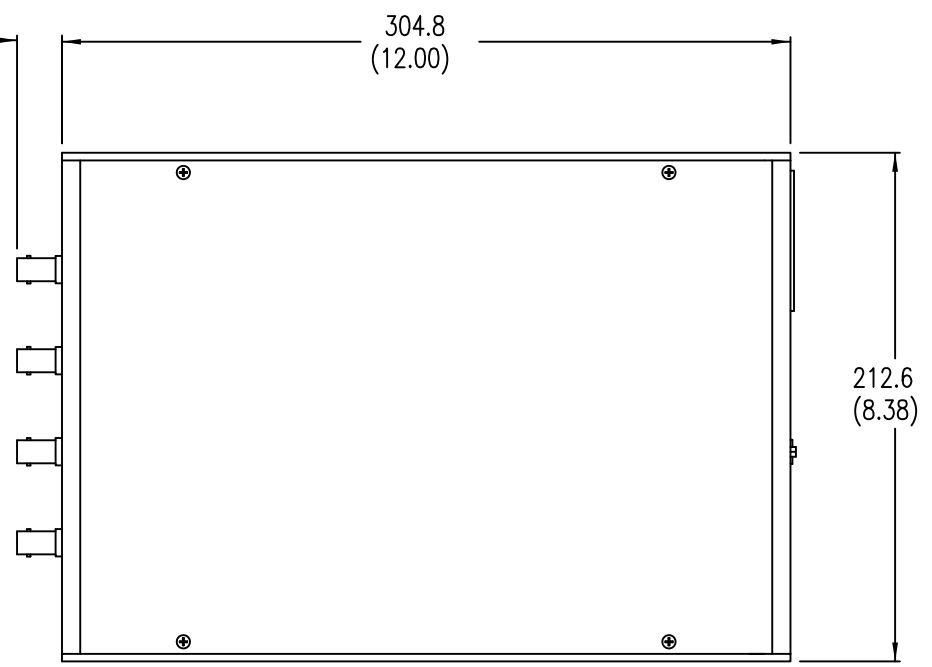

BNC/F	18.8 (.74)
F/F	9.65 (.38)
CONNECTOR TYPE	DIM "A"

NOTES:
1. ALL DIMENSIONS GIVEN IN MM (INCHES)

INTERFACE CONTROL DRAWING

PROPRIETARY NOTICE
THIS DOCUMENT IS COMMERCIAL CONFIDENTIAL AND THE INFORMATION CONTAINED THEREIN MAY NOT BE DISSEMINATED, NOR IS REPRODUCTION PERMITTED EXCEPT BY WRITTEN AUTHORIZATION.

QTY REQD	FSCM NO.	PART OR IDENTIFYING NO.	NOMENCLATURE OR DESCRIPTION	MATERIAL SPECIFICATION
PARTS LIST				
UNLESS OTHERWISE SPECIFIED DIMENSIONS ARE IN INCHES TOLERANCES ARE: FRACTIONS DECIMALS ANGLES $\pm 1/64$.XX $\pm .01$ $\pm 1/2^\circ$ XXX $\pm .003$		CONTRACT NO.	AEROFLEX WEINSCHEL	
MATERIAL		APPROVALS	DATE	ICD, ATTENUATOR UNIT, MODEL 8310 (75 OHM) W/ETHERNET
NEXT ASSY		DRAWN	M. TYSON	
USED ON		CHECKED	A. HOPKINS	
APPLICATION		ENGR.	W. KNILL	SIZE C
DO NOT SCALE DRAWING		ISSUED		FSCM NO. 93459
				DWG. NO. 089-4052
				REV. A
				SCALE 1/2
				SHEET 1 OF 2

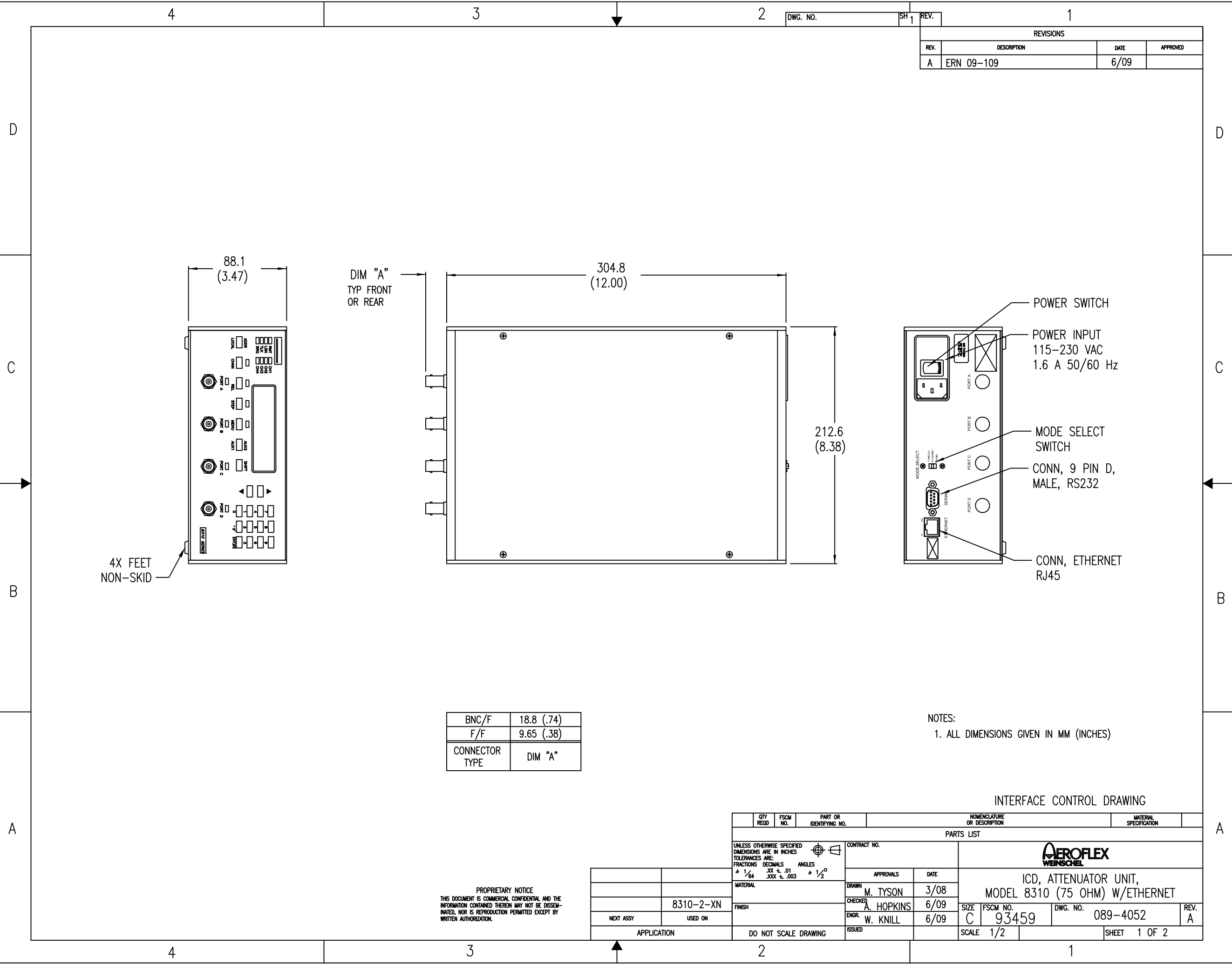

4

3

2

1

DWG. NO. SH 2 REV.

REVISIONS			
REV.	DESCRIPTION	DATE	APPROVED
	SEE SHEET 1		

D

D

C

C

MODEL NO.	ATTEN VALUE	FREQ RANGE	INSERTION LOSS	SWR	NO. OF CHAN	ATTEN TYPE (1)	CONN TYPE	CONN LOCATION
8310-1-FN	63/1	DC-1.0 GHz (75 OHMS)	6.0 dB MAX	1.6 MAX	1	3250T-63	BNC/F	FRONT
8310-1-RN	63/1	DC-1.0 GHz (75 OHMS)	6.0 dB MAX	1.6 MAX	1	3250T-63	BNC/F	REAR
8310-1-2-FN	63/1	DC-1.0 GHz (75 OHMS)	6.0 dB MAX	1.6 MAX	2	3250T-63	BNC/F	FRONT
8310-1-2-RN	63/1	DC-1.0 GHz (75 OHMS)	6.0 dB MAX	1.6 MAX	2	3250T-63	BNC/F	REAR
8310-1-3-TN	63/1	DC-1.0 GHz (75 OHMS)	6.0 dB MAX	1.6 MAX	3	3250T-63	BNC/F	FRONT/REAR
8310-2-FN	63/1	DC-1.0 GHz (75 OHMS)	6.0 dB MAX	2.0 MAX	1	3250T-63	F/F	FRONT
8310-2-RN	63/1	DC-1.0 GHz (75 OHMS)	6.0 dB MAX	2.0 MAX	1	3250T-63	F/F	REAR
8310-2-2-FN	63/1	DC-1.0 GHz (75 OHMS)	6.0 dB MAX	2.0 MAX	2	3250T-63	F/F	FRONT
8310-2-2-RN	63/1	DC-1.0 GHz (75 OHMS)	6.0 dB MAX	2.0 MAX	2	3250T-63	F/F	REAR

(1) SEE ATTENUATOR INTERFACE CONTROL DRAWING FOR RF SPECIFICATIONS

B

B

A

A

PROPRIETARY NOTICE
 THIS DOCUMENT IS COMMERCIAL CONFIDENTIAL AND THE
 INFORMATION CONTAINED THEREIN MAY NOT BE DISSEM-
 INATED, NOR IS REPRODUCTION PERMITTED EXCEPT BY
 WRITTEN AUTHORIZATION.

QTY REQD	FSCM NO.	PART OR IDENTIFYING NO.	NOMENCLATURE OR DESCRIPTION	MATERIAL SPECIFICATION
		8310-2-XN	ICD, ATTENUATOR UNIT, MODEL 8310 (75 OHM) W/ETHERNET	
			CONTRACT NO.	
			APPROVALS	DATE
			CHECKED	
			ENGR.	
			ISSUED	
			SCALE 1/2	SHEET 2 OF 2

UNLESS OTHERWISE SPECIFIED
 DIMENSIONS ARE IN INCHES
 TOLERANCES ARE:
 FRACTIONS DECIMALS ANGLES
 $\pm 1/64$.XX $\pm .01$ $\pm 1/2^\circ$
 .XXX $\pm .003$

FINISH: DO NOT SCALE DRAWING

SIZE: C FSCM NO. 93459 DWG. NO. 089-4052 REV. A

4

3

2

1

DWG. NO.		REV.		REVISIONS	
ZONE	REV.	DESCRIPTION	DATE	APPROVED	
A	ERN 08-086	VB	05/08		

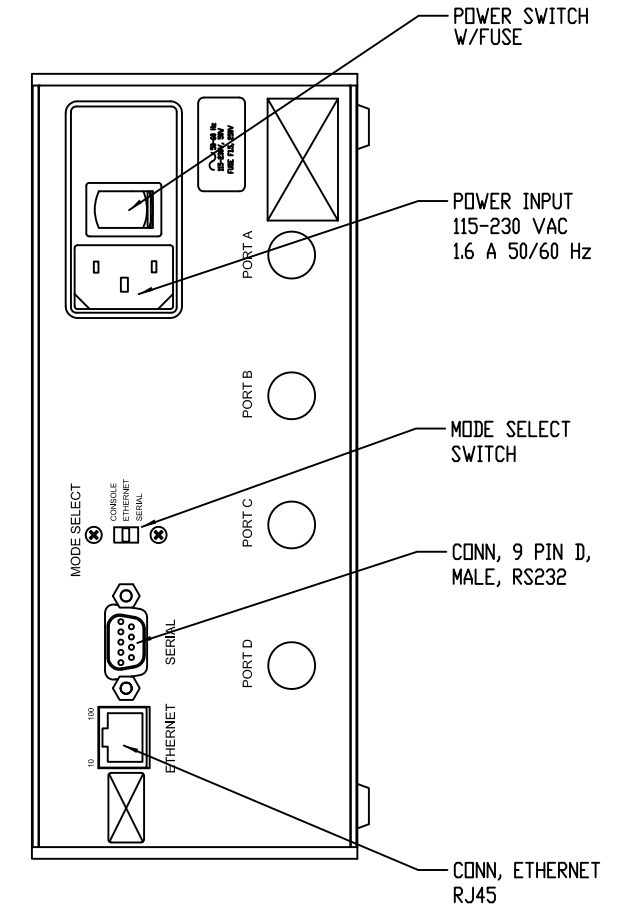
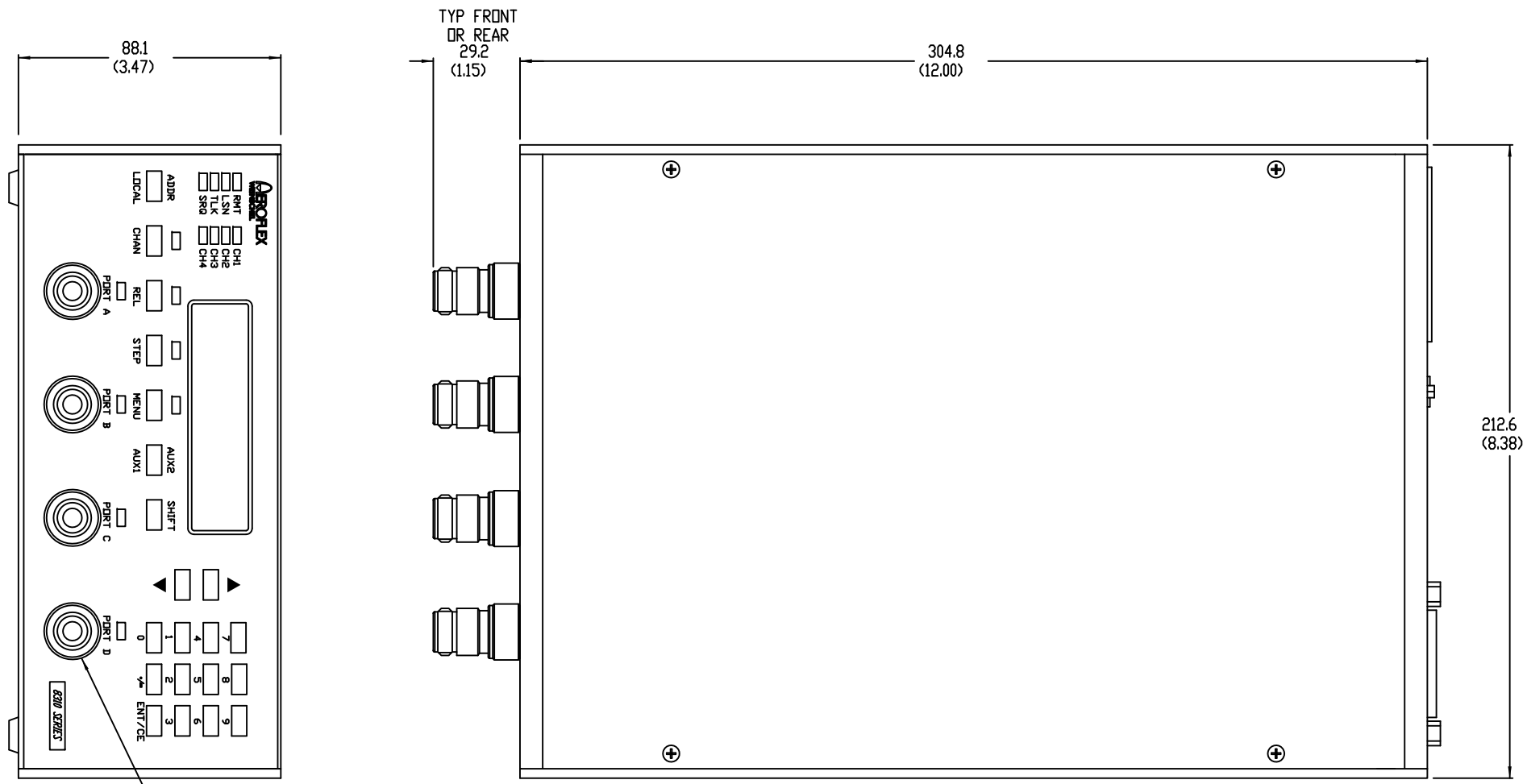

CONNECTOR, TYPE N FEMALE PLANAR CROWN

MODEL NUMBER	ATTEN VALUE	FREQ RANGE	INSERTION LOSS	SWR	NO OF CHAN	ATTEN TYPE (1)	CONN TYPE	CONN LOCATION
8310-135-FN	127/1	0.8 - 3.0 GHz	(2)	1.6 MAX	1	4228-127	N/F	FRONT
8310-135-RN	127/1	0.8 - 3.0 GHz	(2)	1.6 MAX	1	4228-127	N/F	REAR
8310-135-2-FN	127/1	0.8 - 3.0 GHz	(2)	1.6 MAX	2	4228-127	N/F	FRONT
8310-135-2-RN	127/1	0.8 - 3.0 GHz	(2)	1.6 MAX	2	4228-127	N/F	REAR
8310-136-FN	63.75/0.25	0.8 - 2.5 GHz	6.0 dB MAX	1.5 MAX	1	4228-63.75	N/F	FRONT
8310-136-RN	63.75/0.25	0.8 - 2.5 GHz	6.0 dB MAX	1.5 MAX	1	4228-63.75	N/F	REAR
8310-136-2-FN	63.75/0.25	0.8 - 2.5 GHz	6.0 dB MAX	1.5 MAX	2	4228-63.75	N/F	FRONT
8310-136-2-RN	63.75/0.25	0.8 - 2.5 GHz	6.0 dB MAX	1.5 MAX	2	4228-63.75	N/F	REAR
8310-137-FN	63/1	0.8 - 3.0 GHz	4.7 dB MAX	1.5 MAX	1	4226-63	N/F	FRONT
8310-137-RN	63/1	0.8 - 3.0 GHz	4.7 dB MAX	1.5 MAX	1	4226-63	N/F	REAR
8310-137-2-FN	63/1	0.8 - 3.0 GHz	4.7 dB MAX	1.5 MAX	2	4226-63	N/F	FRONT
8310-137-2-RN	63/1	0.8 - 3.0 GHz	4.7 dB MAX	1.5 MAX	2	4226-63	N/F	REAR
8310-137-3-TN	63/1	0.8 - 3.0 GHz	4.7 dB MAX	1.5 MAX	2	4226-63	N/F	FRONT/REAR
8310-137-4-TN	63/1	0.8 - 3.0 GHz	4.7 dB MAX	1.5 MAX	2	4226-63	N/F	FRONT/REAR
8310-138-FN	103/1	0.8 - 3.0 GHz	6.5 dB MAX	1.5 MAX	1	4228-103	N/F	FRONT
8310-138-RN	103/1	0.8 - 3.0 GHz	6.5 dB MAX	1.5 MAX	1	4228-103	N/F	REAR
8310-138-2-FN	103/1	0.8 - 3.0 GHz	6.5 dB MAX	1.5 MAX	2	4228-103	N/F	FRONT
8310-138-2-RN	103/1	0.8 - 3.0 GHz	6.5 dB MAX	1.5 MAX	2	4228-103	N/F	REAR
8310-138-3-TN	103/1	0.8 - 3.0 GHz	6.5 dB MAX	1.5 MAX	3	4228-103	N/F	FRONT/REAR
8310-138-4-TN	103/1	0.8 - 3.0 GHz	6.5 dB MAX	1.5 MAX	4	4228-103	N/F	FRONT/REAR

NOTES:
1. ALL DIMENSIONS GIVEN IN MM (INCHES)

INTERFACE CONTROL DRAWING

PROPRIETARY NOTICE
THIS DOCUMENT IS COMMERCIAL CONFIDENTIAL AND THE INFORMATION CONTAINED THEREIN MAY NOT BE DISSEMINATED, NOR IS REPRODUCTION PERMITTED EXCEPT BY WRITTEN AUTHORIZATION.

QTY REQD	FSCM NO.	PART OR IDENTIFYING NO.	MEMORANDUM OR DESCRIPTION	MATERIAL SPECIFICATION	ZONE	ITEM NO.
PARTS LIST						
UNLESS OTHERWISE SPECIFIED DIMENSIONS ARE IN INCHES FRACTIONS DECIMALS ANGLES ± 1/64 ± .001 ± .002 ± 1/8						
CONTRACT NO.		ICD, ATTENUATOR UNIT MODEL 8310 (+5V)				
APPROVALS	DATE					
V. BETSIS	05/08					
CHECKED	DATE					
A. HOPKINS	05/08					
ENGR.	DATE	SIZE	FSCM NO.	DWG. NO.	REV.	
W. KNILL	05/08	D	93459	089-4066	A	
ISSUED		SCALE	SHEET 1 OF 1			
		1/1				

(1) SEE ATTENUATOR INTERFACE CONTROL DRAWING FOR RF SPECIFICATIONS
(2) 0.8 - 2.5 GHz : 6.0 MAX
2.5 - 3.0 GHz : 7.2 MAX

APPENDIX A

CARE AND HANDLING OF MICROWAVE COAXIAL CABLE ASSEMBLIES

A-1 CARE AND HANDLING OF ASSEMBLIES.

To ensure accurate measurements and optimal performance of Weinschel products, the microwave coaxial cable assemblies used in system and test setups must be properly used and maintained. Proper connections, routine inspection of all cables, and cleaning of the connectors are extremely important procedures which can prolong the longevity and accuracy of equipment.

A-2 CABLE INSPECTION.

Routinely check external cables for signs of cracked insulation, dents, twists, flattening, signs of jacket abrasion, or other signs of abuse. Wrinkles in the jacket indicate that the minimum bend radius has been exceeded. Most often, this occurs near the marker tubes and connectors.

Also inspect the connector interfaces for the following:

- Bent pins (male).
- Bent or missing tines (female).
- Worn or chipped plating.
- Damaged or displaced dielectric inserts.
- Thread damage.
- Folded or mushroomed outer interface rims.
- Mushroomed pin shoulders (male) or tine ends (female).
- Score lines on pins and outer interface rims visible to the unaided eye.
- Recessed or protruding pins.

It is advisable to clean the connectors prior to inspection to make subtle damage more apparent. If any of the above is noted, replace the assembly before its further use results in equipment damage. Also inspect the mating connectors for similar damage.

Inspect the connector interface for signs of debris. Debris may be in the form of:

- Plating chips or other metal particles.
- Dust or dirt.
- Oily films.
- Other miscellaneous foreign particles.

If signs of debris are present, clean the connector interface as directed in Paragraph A-6.

A-3 MAKING INITIAL CONNECTIONS.

Exercise caution when mating cables. Poor connections lead to poor system performance. They can also damage not only the cable assembly, but more significantly, front or rear panel connectors on the equipment itself which may be more difficult to repair.

A-3.1 ALIGNING CONNECTORS. Align the center lines of two connectors before actual mating. Male retaining nuts contain a small amount of necessary play which may make it possible to mate the threads without the pins being properly aligned. Pin misalignment can damage pins and dielectric inserts.

A-3.2 MATING CONNECTORS. Gently mate the connectors by hand, taking care not to force the coupling nut at the slightest resistance. It is often possible to feel whether or not the pins are mated. If the coupling nut is difficult to turn, either the pins are not mated, the coupling nut is cross-threaded, or one of the connectors has been damaged by excess torque.

Never hold a male connector coupling nut stationary while screwing a female connector into it. This rotation can erode the plating and damage both the outer interface rim as well as the pin. If the pins become locked, serious damage can result to both the equipment and the cable assembly.

A-4 ENSURING PROPER CONNECTOR TORQUE.

A-4.1 OVERTORQUING. Once connectors have been properly mated, apply only the proper amount of torque. Overtorquing damages both connectors involved. Also, a connector which has been damaged by overtorquing, in turn, damages every connector to which it is subsequently mated. It usually leads to poor system performance as well. Overtorque can cause:

- Bent pins.
- Recessed or protruding pins.
- Recessed or protruding dielectrics.
- Chipped plating.
- Damaged coupling threads.
- Coupling nut retaining ring damage.
- Mushroomed outer interface shells.
- Mushroomed pin shoulders.

A-4.2 HEX-NUT TYPES. To mate a connector of the hex-nut type, always use a torque wrench set to the correct torque value. Tighten the connector slowly until the wrench snaps. Tightening too quickly can cause the wrench to exceed its set limit. Do not snap the wrench more than once as this also causes overtorque.

A-4.3 KNURLED NUTS. Tighten connectors with knurled nuts by hand. If this does not provide sufficient tightness use a hex-nut connector and torque wrench instead. Never use pliers to tighten a connector. Table A-1 recommends torque specifications for the various types of connectors.

Table A-1. Recommended Torque Values

Connector	Recommended Torque
GPC-7 (7mm) w/hex nut	14 in/lbs ± 1 in/lbs
Type N w/hex nut	14 in/lbs ± 1 in/lbs
SMA, 2.92mm, 3.5mm 2.4mm, WPM, WPM-3 WPM-4	7.5 in/lbs ± 0.5 in/lbs
Type N & TNC (knurled)	Hand-tight
BNC (knurled)	Hand-tight

A-5 PROPER CABLE HANDLING.

Never exceed the minimum bend radius specified for a cable. Guard against tight bends at the end of connector strain relief tubing, or at the ends of marker tubing where they may be less noticeable. Although cable bend may seem slight, the actual radius of the bend at the point of angular departure may be far smaller than the acceptable radius.

Never pinch, crush or drop objects on cable assemblies. Also, do not drag a cable over sharp edges as this will pinch it and cause it to exceed the minimum bend radius.

Never use a cable assembly to pull a piece of equipment. Cables and connectors are not designed to support or move equipment.

A-5.1 SECURING CABLES. Use toothed, rubber-lined "P-clamps" to hold cables in place. If it is necessary to use tie-wraps, use the widest possible wrap and the lowest setting on the gun to ensure the minimum pressure on the cable.

A-5.2 STORING CABLES.When storing cables, minimize cable "set" by coiling them in large diameters (1 or 2 feet). Unroll the cable properly when it is ready to be used; do not pull the loops out hastily. Similarly, re-roll them when storing them away again.

A-6 CLEANING CONNECTOR INTERFACES.

Use the following guidelines in cleaning connector interfaces:

- a. Do not use chlorinated solvents including common tap water. These solvents are extremely penetrating and sometimes ruin otherwise good devices and assemblies.
- b. Moisten a cotton swab with isopropyl alcohol. Roll the swab on a paper towel to remove excess.
- c. Use the moistened cotton swab to wipe away debris. Do not try to dissolve the debris by overwetting the swab.
- d. Repeat the cleaning process using additional swabs as necessary. If metallic particles are embedded in the dielectric, use an eyeglass and a sharp pick in an attempt to dislodge them. Swab again.
- e. When satisfied that the interfaces are clean, blow them dry with dry compressed air, or preferably dry nitrogen (pressurized spray cans work well). Do not use breath.
- f. Clean the mating connectors. These may be the source of the debris.

Model 8310 w/Ethernet (IM-493) Revision Record

REVISION	DATE	DESCRIPTION	APPLICABLE SERIAL NUMBERS
A	8/08	Initial Issue	All Units
B	9/08	Added Models 8310-352-1-XN, 8310-352-3-TN, 8310-352-4-TN & 8310-138-X-XN Series	All new Units
C	8/09	Added Model 8310-1-XN, 8310-38-XN & 8310-2-XN Series	All New Units
D	12/09	Added Model 8310-36-XN Series	All New Units
E	1/09	Added Model 8310-35-XN Series	All New Models
G	4/18/11	Incorporated Aeroflex / Weinschel ECN 11-079. ECN adds additional operation instructions for the Lantronix XPort™ Ethernet. Changed Storage Temperature to 4° to +167 °F (-20° to +75 °C)	All Models

EC DECLARATION OF CONFORMITY

This is to certify that the:

SmartStep Attenuator Unit 8310 Series

Manufactured by:

Weinschel Corporation

Conforms with the protection requirements of Council Directive 89/336/EEC and the Amending Directive 93/68/EEC, relating to Electromagnetic Compatibility and Council Directive 73/23/EEC relating to LVD (Safety), by the application of:

EN50081-1: 1992 Generic Emissions Standard.
(Class B Equipment)

EN50082-1: 1992 Generic Immunity Standard.
(Class B Equipment)

EN61010-1: 1993 Safety requirements for electrical equipment for measurement, control and laboratory use.

Signed:  Position: Subsystem Manager

Of: Weinschel Corp. Date: 10/1/1999