

Aeroflex / Weinschel Subsystems

8 X 16 Switch Matrix Design Concept

28 July 2004

Prepared by:



5305 Spectrum Drive, Frederick, MD 21703
301-846-9222 • Fax: 301-846-9116 • www.aeroflex-weinschel.com

© COPYRIGHT 2004 Aeroflex / Weinschel Inc.
All Rights Reserved.

TABLE OF CONTENTS

1	INTRODUCTION	3
2	SCOPE	3
3	GENERAL SPECIFICATIONS	4
3-1	RF SPECIFICATIONS	4
3-2	DESIGN	5
3-3	INTERCONNECTIONS	6
3-4	ETHERNET SNMP SPECIFICATIONS	9
3-5	CERTIFICATION	9
3-6	QUALITY ASSURANCE	9
4	WARRANTY	9
5	AVAILABILITY	9

INTELLECTUAL PROPERTY NOTICE

The design concepts presented in this paper are offered for consideration in developing specific solutions for our customers, and remain the exclusive property of Aeroflex / Weinschel. Any unauthorized copying, distribution, or conversion of the contents of this paper for other purposes without the prior written consent of Aeroflex / Weinschel is strictly prohibited.

1 Introduction

Aeroflex / Weinschel is pleased to present this technical paper describing an 8 x 16 Switch Matrix. Designs of this type are intended for use as a remote controllable RF patch panel. Weinschel develops and manufactures high-quality, high-reliability microwave and RF components and Subsystems. Aeroflex / Weinschel has over 25 years of product development experience in satellite and communications systems, test, measurement and simulation of wireless systems, including 3G, WCDMA, PCS, and GSM; cable modem test sets and precision microwave and RF instrumentation. Aeroflex / Weinschel is well positioned to deliver designs based upon this 8 x 16 Switch Matrix.

The Switch Matrix is a modular design, allowing the end customer to configure either 8 x 8 or 8 x 16 configurations with only minor factory, board level modifications. The basic design uses latching relays so that the signal path integrity can be maintained even during power outages or loss of Ethernet control. The switch matrix can be delivered either as a 50 Ohm or 75 Ohm system.

Aeroflex / Weinschel invites customer inquiries based upon this conceptual design, and offers a wide range of design flexibility to address specific customer needs.

2 Scope

Aeroflex / Weinschel's design approach uses a highly adaptable platform that allows a dense integration of switches. The switch matrix chassis contains sixteen, 8x1 switch modules and eight, 16x1 modules. Once a system is fielded it can be maintained through the exchange of front and rear panel switches, the Ethernet controller and power modules. The Switch Matrix System software can be controlled through a 10 Base T TCP/IP software link. Field level software upgrades or maintenance will be available through a TCP/IP link.

3 General Specifications

3-1 RF Specifications:

<u>Specifications:</u>	<u>Standard</u>	<u>Goal</u>
Switch	Electromechanical	Electromechanical
Frequency:	DC-2200MHz	DC-2200MHz
Configuration:	8x16 blocking matrix	8x16 blocking matrix
Impedance:	50 ohm**	50 ohm**
Insertion Loss:	4 dB	2.2-2.8 dB
RF Input Power:	30 dBm	30 dBm
Isolation:	45 dB	45-60 dB
RF connector:	TNC Female*** 8 Connector Front, 16 Connector Back	TNC Female*** 8 Connector Front, 16 Connector Front or Back
Size:	10.5 h x 19 w x 20 d	10.5 h x 19 w x 20 d
VSWR:	1.6	1.4
Control:	Ethernet SNMP	Ethernet SNMP

** Please call for details on the 75 Ohm version of this subsystem.

*** Alternate RF connectors available.

3-2 Design

The design will be an interface of sixteen, 1x 8 switches (**Figure 3**) and eight, 1x16 switches (**Figure 2**). The multi-throw switch design will be based on the use of signal relays. The 1 x 8 switch is shown in **Figure 1**.

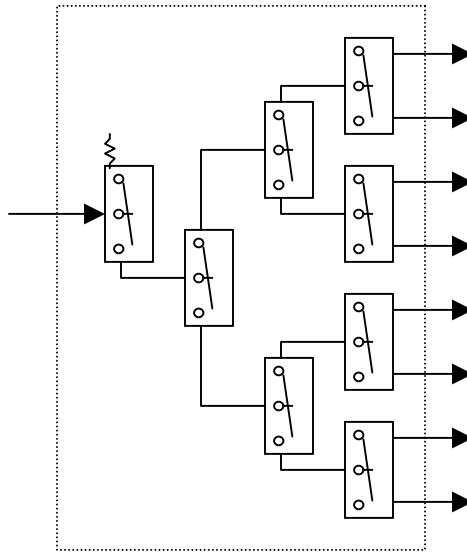

Figure 1. 1 X 8 switch Implementation with 8 Relays

The signal trace forms a tee to connect to the final two output relays. This is to eliminate one layer of switching, improving the insertion loss and reducing the cost. The 1 x 16 switch will also employ this feature, therefore 16 relays will be needed to implement the design.

Total relays	8 – 1 x 16 switches, 8 x 16 = 128
	16 – 1 x 8 switches, 16 x 8 = <u>128</u>
	256

3-3 Interconnections

The sixteen, 1 x 8 switches will mate with the eight, 1x 16 switches. This requires 128 interconnects.

The 1 x 8 cards slide in the front of the 10.5” positioned vertically, and the 1 x 16 cards slide in the rear of the 10.5” rack positioned horizontally. **(Figure 5)** This interface, **(Figure 4)** is made by a Blind mate connector.

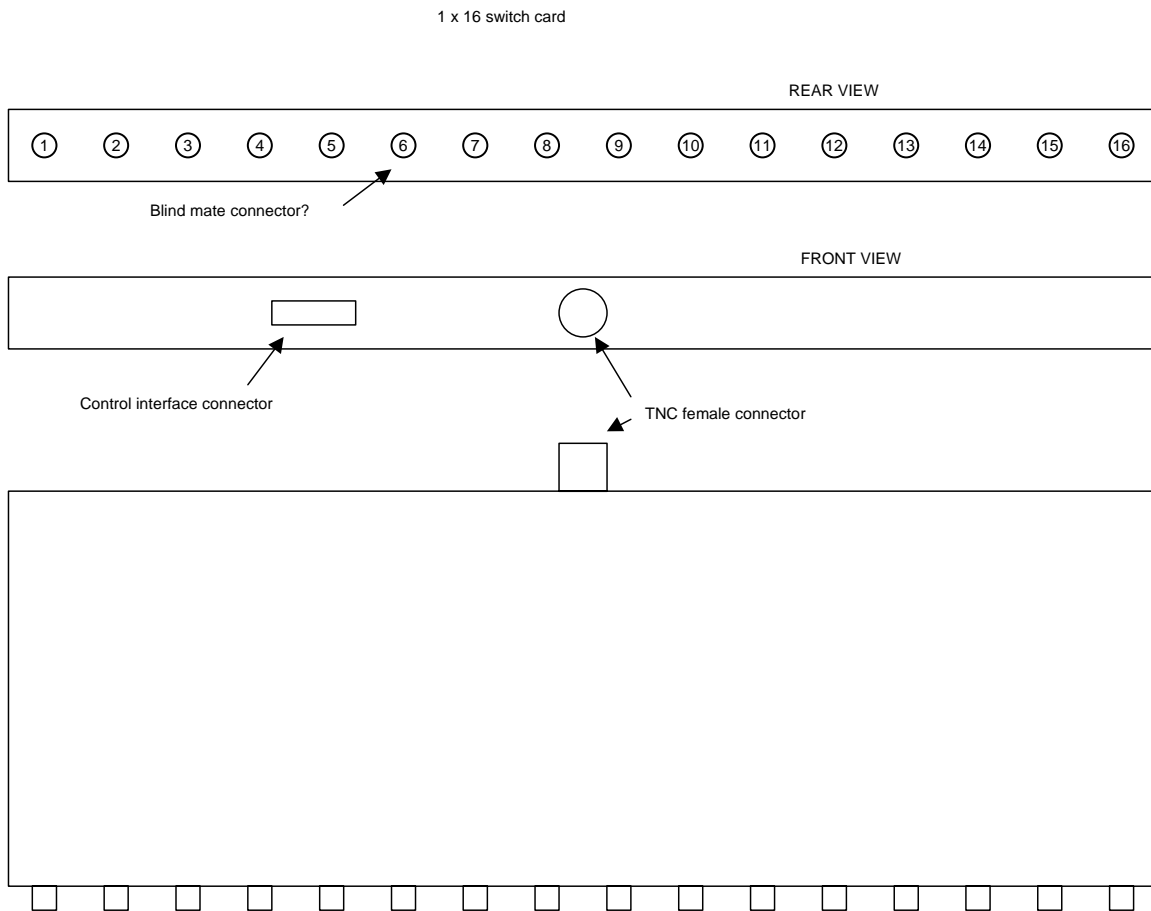

Figure 2. 1 x 16 Switch Card

1 x 8 switch card

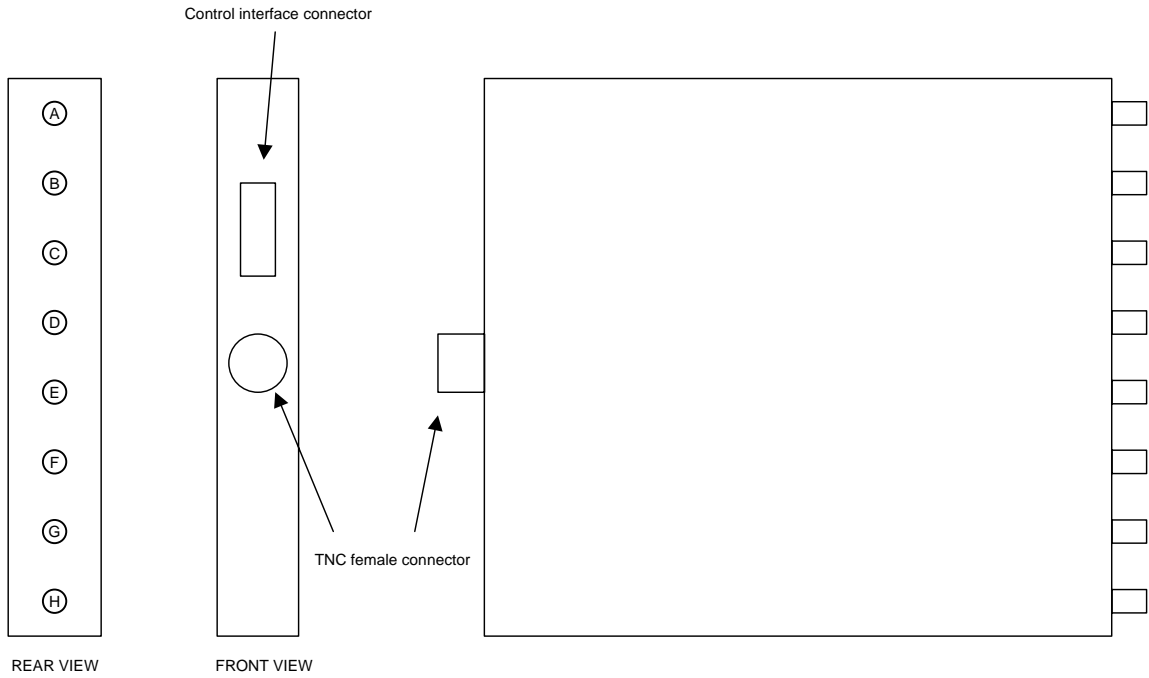
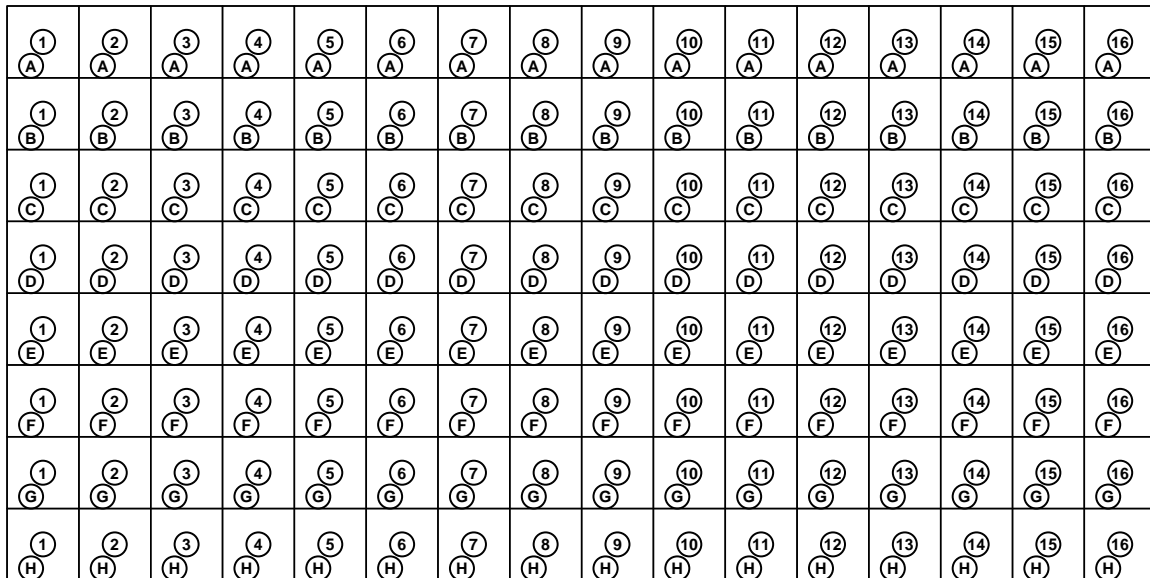

Figure 3. 1 x 8 Switch Card



View of interconnects in center of box

Figure 4. Interface Plane for Method 1

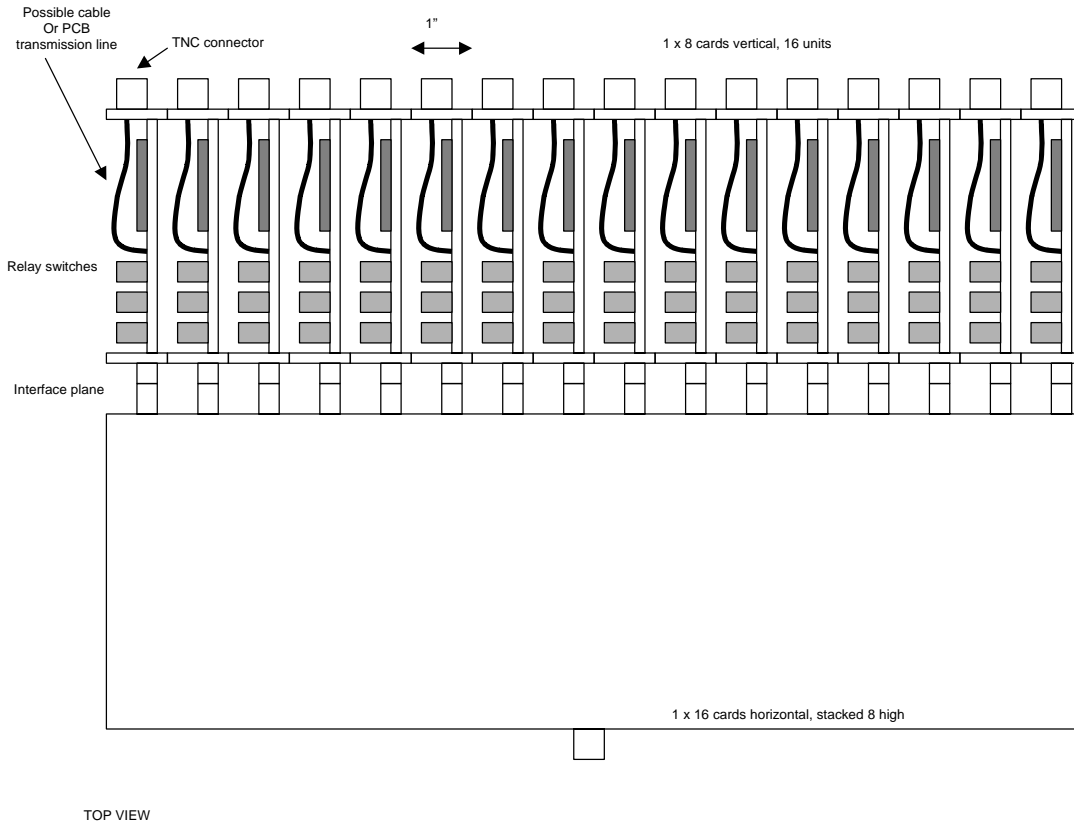

Figure 5. Top View -- Method 1

3-4 Ethernet SNMP Specifications

The switch matrix will have a 10 Base T Ethernet Interface with an RJ45 Connector. The interface will comply with SNMP protocol. The parameters, which will be controllable or accessible over the control interface, will be:

1. System S/N
2. System board S/N's
3. SW Revision level
4. Individual switch positions
5. Inquiry of switch position
6. System Fault Reports
7. System Address status
8. System address set
9. Download new software revision

3-5 Certification

The 8x16 switch matrix will have a CE certification.

3-6 Quality Assurance

Aeroflex / Weinschel will implement its standard quality assurance program for development, fabrication, assembly, alignment and test of the deliverable items. This program supports compliance with the inspection requirements of ISO 9001.

4 Warranty

Aeroflex / Weinschel supplies a one year warranty on all proprietary equipment. All units under warranty that need repair will be repaired at the Frederick Maryland facility.

5 AVAILABILITY

This paper describes both a Weinschel capability and a specific conceptual design for an 8 x 16 Switch Matrix, but not an existing product. Product availability and delivery will be dependant upon specific customer requirements and quantities required.

Aeroflex / Weinschel has earned a reputation in the industry as a responsive supplier of both electronic components and subsystems. We invite your specific inquiries, and will work with your designers and requirements to formulate a subsystem approach that is both compliant with your technical needs, and timely with regard to your development schedule.