

MUX8531 16-Channel Analog Multiplexer Module Radiation Tolerant & ESD Protected Kelvin Measurement Configured

www.aeroflex.com/mux

April 20, 2009



FEATURES

- 16 Kelvin measurement channels provided by two 16-channel multiplexers
- Radiation performance
 - Total dose: 150 krad(Si), Dose rate = 50 - 300 rads(Si)/s
 - SEU: Immune up to 90 MeV-cm²/mg
 - SEL: Immune by process design
- Full military temperature range
- Low power consumption < 30mW
- One address bus (A0-3), and one enable line
- All channel inputs protected by ±20V nominal Transorbs
- Fast access time < 500ns typical
- Break-Before-Make switching
- High analog input impedance (power on or off)
- Designed for aerospace and high reliability space applications
- Packaging – Hermetic ceramic
 - 56 leads, 0.80" Sq x 0.20"Ht quad flat pack
 - Typical Weight 6 grams
- DSCC SMD 5962-09230 pending

Note: Aeroflex Plainview does not currently have a DSCC certified Radiation Hardened Assurance Program.

GENERAL DESCRIPTION

Aeroflex's MUX8531 is a radiation tolerant, 16 Kelvin measurement channel multiplexer MCM (Multi Chip Module) with electrostatic discharge (ESD) protection on all channel inputs.

The MUX8531 has been specifically designed to meet exposure to radiation environments. It is available in a 56 lead High Temperature Co-Fired Ceramic (HTCC) Quad Flatpack (CQFP). It is guaranteed operational from -55°C to +125°C. Available screened in accordance with MIL-PRF-38534, the MUX8531 is ideal for demanding military and space applications.

ORGANIZATION AND APPLICATION

The MUX8531 consists of two 16 channel multiplexers arranged as shown in the block diagram, addressable by bus A₀~A₃ including enable which connects the addressed channel to two separate outputs, "Output" and "Current". This technique enables selecting and reading a remote resistive sensor without the MUX resistance being part of the measurement. For grounded sensors, this is done by passing current to the sensor by means of the "Current" pin and reading the resultant voltage (proportional to the sensor resistance) at the "Output" pin.

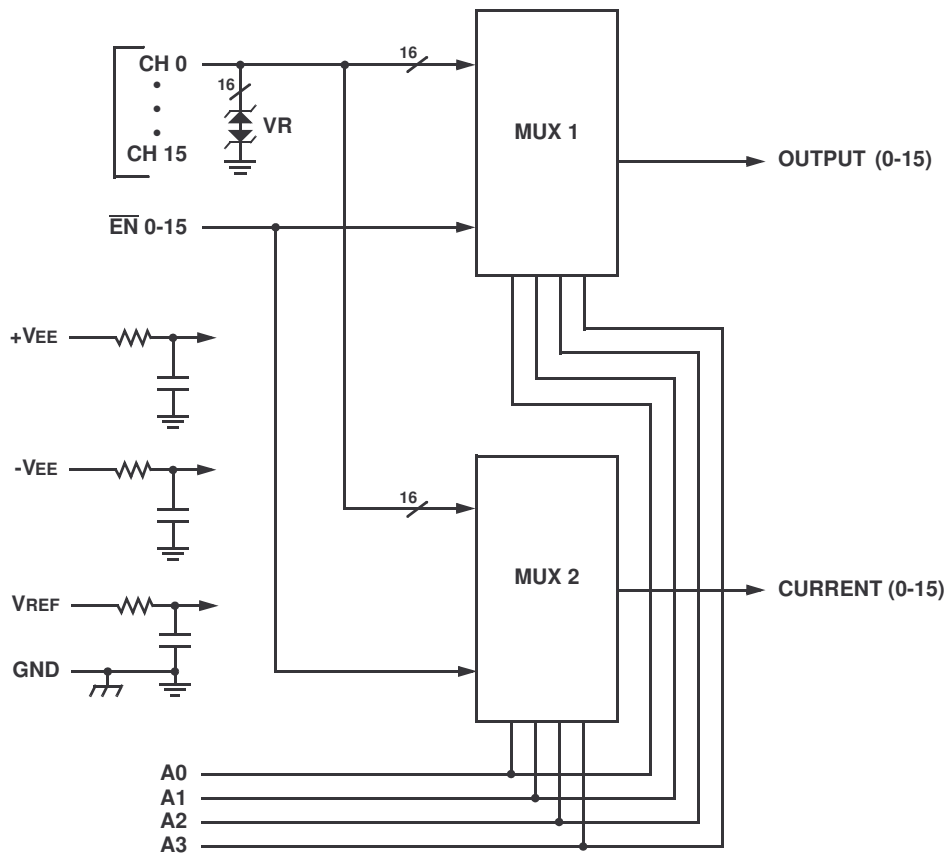

**MUX8531: 16 CHANNEL ANALOG MUX BLOCK DIAGRAM
KELVIN MEASUREMENT CONFIGURED**

ABSOLUTE MAXIMUM RATINGS ^{1/}

Parameter	Range	Units
Case Operating Temperature Range	-55 to +125	°C
Storage Temperature Range	-65 to +150	°C
Supply Voltage +VEE (Pin 18) -VEE (Pin 46) VREF (Pin 39)	+20 -20 +7.5	V V V
Digital Input Overvoltage VEN (Pin 13), VA (Pins 14, 15, 16, 17)	< VREF +.5 > GND -.5	V V
Analog Input Over Voltage VS	±18V	V

Notes:

^{1/} All measurements are made with respect to ground.

NOTICE: Stresses above those listed under "Absolute Maximums Rating" may cause permanent damage to the device. These are stress rating only; functional operation beyond the "Operation Conditions" is not recommended and extended exposure beyond the "Operation Conditions" may affect device reliability.

RECOMMENDED OPERATING CONDITIONS ^{1/}

Symbol	Parameter	Typical	Units
+VEE	+15V Power Supply Voltage	+15.0	V
-VEE	-15V Power Supply Voltage	-15.0	V
VREF	Reference Voltage	+5.00	V
VAL	Logic Low Level	+0.8	V
VAH	Logic High Level	+4.0	V

^{1/} Power Supply turn-on sequence shall be as follows: -VEE, VREF, followed by +VEE.

DC ELECTRICAL PERFORMANCE CHARACTERISTICS ^{1/}

(T_C = -55°C TO +125°C, -VEE = -15V, VREF = +5.0V, +VEE = +15V - UNLESS OTHERWISE SPECIFIED)

Parameter	Symbol	Conditions	Min	Max	Units
Supply Current	+IEE	VEN(0-15) = VA(0-3) = 0	0	1	mA
	-IEE	VEN(0-15) = VA(0-3) = 0	-1	0	mA
	+ISBY	VEN(0-15) = 4V, VA(0-3) = 0 ^{2/}	0	1	mA
	-ISBY	VEN(0-15) = 4V, VA(0-3) = 0 ^{2/}	-1	0	mA
Address Input Current	I _{AL} (0-3)A	VA = 0V	-2	2	μA
	I _{AH} (0-3)A	VA = 5V	-2	2	μA
Enable Input Current	I _{ENL} (0-15)	VEN(0-15) = 0V	-2	2	μA
	I _{ENH} (0-15)	VEN(0-15) = 5V	-2	2	μA

DC ELECTRICAL PERFORMANCE CHARACTERISTICS 1/ (continued)

(T_C = -55°C TO +125°C, -V_{EE} = -15V, V_{REF} = +5.0V, +V_{EE} = +15V - UNLESS OTHERWISE SPECIFIED)

Parameter	Symbol	Conditions	Min	Max	Units	
Positive Input Leakage Current CH0-CH15	+ISOFFOUTPUT(ALL)	V _{IN} = +10V, V _{EN} = 4V, output and all unused MUX inputs under test = -10V 2/, 3/	-100	+1000	nA	
Negative Input Leakage Current CH0-CH15	-ISOFFOUTPUT(ALL)	V _{IN} = -10V, V _{EN} = 4V, output and all unused MUX inputs under test = +10V 2/, 3/	-100	+1000	nA	
Positive Output Leakage Current OUTPUTS (pins 12,45)	+IDOFFOUTPUT(ALL)	V _{OUT} = +10V, V _{EN} = 4V, output and all unused MUX inputs under test = -10V 3/, 4/	-100	+100	nA	
Negative Output Leakage Current OUTPUTS (pins 12,45)	-IDOFFOUTPUT(ALL)	V _{OUT} = -10V, V _{EN} = 4V, output and all unused MUX inputs under test = +10V 3/, 4/	-100	+100	nA	
Input Clamped Voltage CH0 - CH15	+VCLMP	V _{EN} = 4V, all unused MUX inputs under test are open. 3/	+25°C	18.0	23.0	V
			+125°C	18.0	23.5	V
Input Clamped Voltage CH0 - CH15	-VCLMP	V _{EN} = 4V, all unused MUX inputs under test are open. 3/	-55°C	17.5	22.5	V
			+25°C	-23.0	-18.0	V
Switch ON Resistance OUTPUTS (pins 12,45) 6/	R _{DS(ON)} (0-15) _A	V _{IN} = +15V, V _{EN} = 0.8V, I _{OUT} = -1mA 2/, 3/, 5/	200	1000	Ω	
	R _{DS(ON)} (0-15) _B	V _{IN} = +5V, V _{EN} = 0.8V, I _{OUT} = -1mA 2/, 3/, 5/	200	1500	Ω	
	R _{DS(ON)} (0-15) _C	V _{IN} = -5V, V _{EN} = 0.8V, I _{OUT} = +1mA 2/, 3/, 5/	200	2500	Ω	

Notes:

- 1/ Measure inputs sequentially. Ground all unused inputs of the device under test. V_A is the applied input voltage to the address lines A(0-3).
- 2/ V_{IN} is the applied input voltage to the input channels CH0-CH15.
- 3/ V_{EN} is the applied input voltage to the enable line EN (0-15).
- 4/ V_{OUT} is the applied input voltage to the output lines OUTPUT (0-15), CURRENT (0-15)
- 5/ Negative current is the current flowing out of each of the MUX pins. Positive current is the current flowing into each MUX pin.
- 6/ The MUX8531 cannot be operated with analog inputs from -15 to -5 volts.
- Z/ Not tested, guaranteed to the specified limits.

SWITCHING CHARACTERISTICS

(T_C = -55°C TO +125°C, -V_{EE} = -15V, V_{REF} = +5.0V, +V_{EE} = +15V -- UNLESS OTHERWISE SPECIFIED)

Parameter	Symbol	Conditions	Min	Max	Units
Switching Test MUX	t _{AHL}	R _L = 10KΩ, C _L = 50pF	10	1000	ns
	t _{ALH}		10	1000	ns
	t _{ONEN}	R _L = 1KΩ, C _L = 50pF	10	1000	ns
	t _{OFFEN}		10	1000	ns

TRUTH TABLE (CH0 – CH15)

A3	A2	A1	A0	$\overline{\text{EN}}$ (0-15)	"ON" CHANNEL <u>1/</u>
X	X	X	X	H	NONE
L	L	L	L	L	CH0
L	L	L	H	L	CH1
L	L	H	L	L	CH2
L	L	H	H	L	CH3
L	H	L	L	L	CH4
L	H	L	H	L	CH5
L	H	H	L	L	CH6
L	H	H	H	L	CH7
H	L	L	L	L	CH8
H	L	L	H	L	CH9
H	L	H	L	L	CH10
H	L	H	H	L	CH11
H	H	L	L	L	CH12
H	H	L	H	L	CH13
H	H	H	L	L	CH14
H	H	H	H	L	CH15

1/ Between CH0-15 and OUTPUT (0-15), CURRENT (0-15)

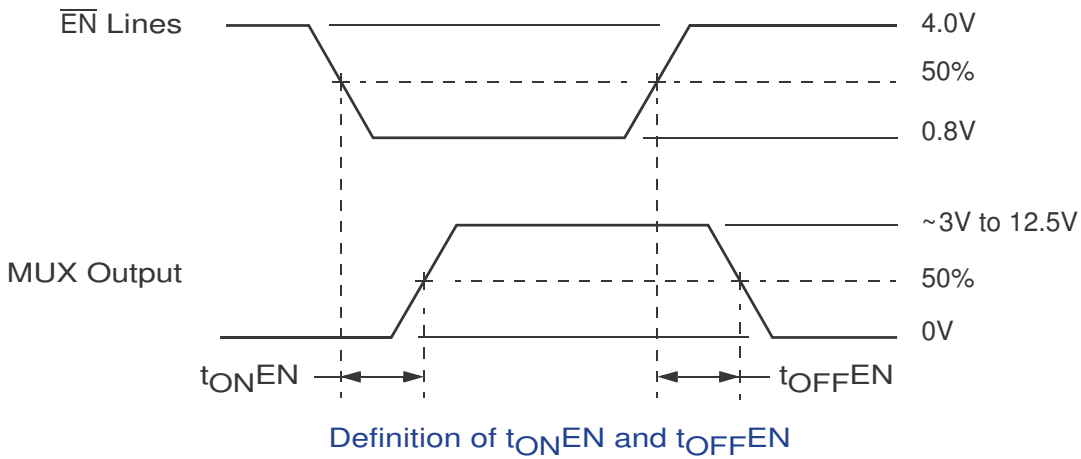
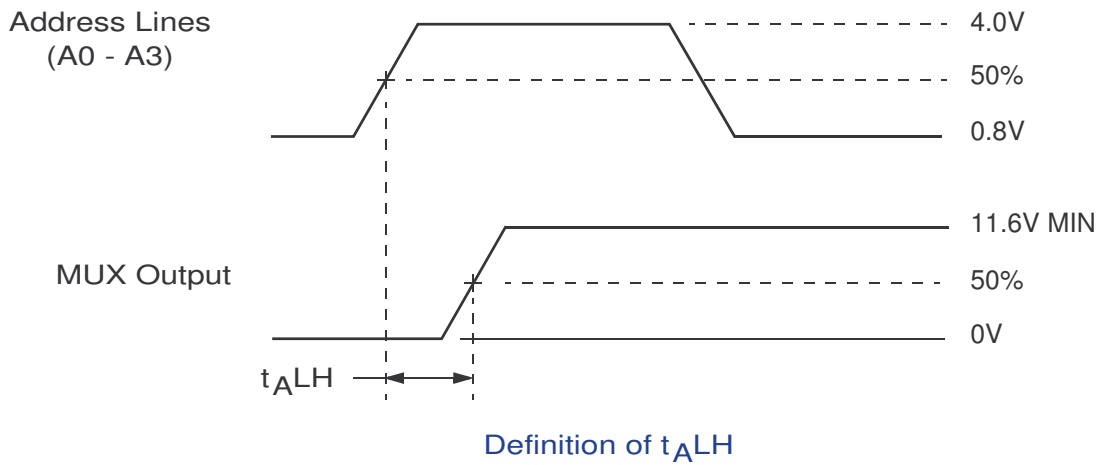
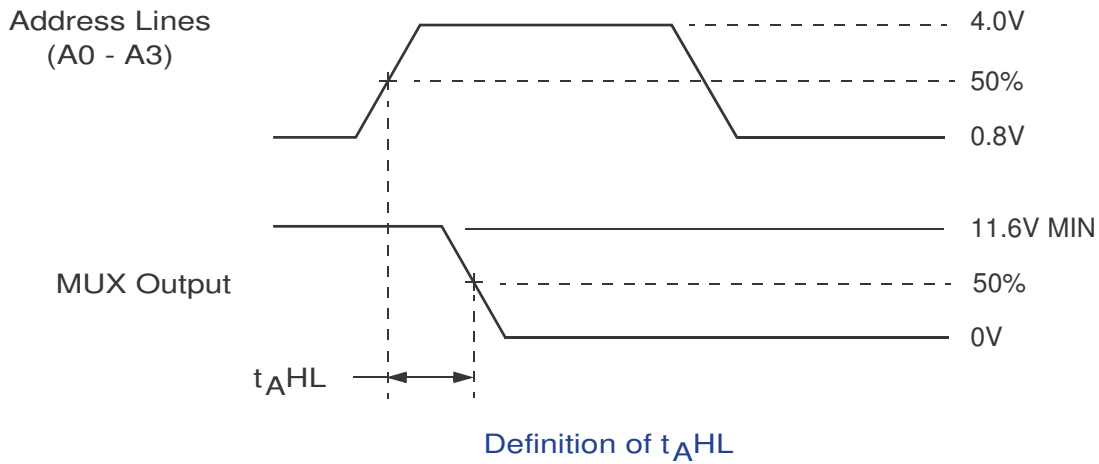

NOTE: $f = 10\text{KHz}$, Duty cycle = 50%.

MUX8531 SWITCHING DIAGRAMS

PIN NUMBERS & FUNCTIONS

MUX8531 – 56 Leads Ceramic QUAD Flat Pack			
Pin #	Function	Pin #	Function
1	CH0	29	NC
2	CH1	30	NC
3	CH2	31	NC
4	CH3	32	NC
5	CH4	33	NC
6	CH5	34	NC
7	GND	35	GND
8	GND	36	GND
9	CH6	37	NC
10	CH7	38	NC
11	CASE GND	39	VREF
12	OUTPUT (0-15)	40	NC
13	$\overline{\text{EN}}$ 0-15	41	NC
14	A0	42	NC
15	A1	43	NC
16	A2	44	NC
17	A3	45	CURRENT (0-15)
18	+VEE	46	-VEE
19	CH15	47	NC
20	CH14	48	NC
21	GND	49	GND
22	GND	50	GND
23	CH13	51	NC
24	CH12	52	NC
25	CH11	53	NC
26	CH10	54	NC
27	CH9	55	NC
28	CH8	56	NC

Notes:

1. It is recommended that all "NC" or "no connect pin", be grounded. This eliminates or minimizes any ESD or static buildup.
2. Package lid is internally connected to circuit ground (Pins 7, 8, 11, 21, 22, 35, 36, 49, 50).

ORDERING INFORMATION

Model	DSCC SMD #	Screening	Package
MUX8531-S	-	Military Temperature, -55°C to +125°C Screened in accordance with MIL-PRF-38534, Class K	QUAD Flat Pack
MUX8531-7	-	Commercial Flow, +25°C testing only	
MUX8531-201-1S	5962-0923002KXC (Pending)	In accordance with DSCC SMD	

PACKAGE OUTLINE

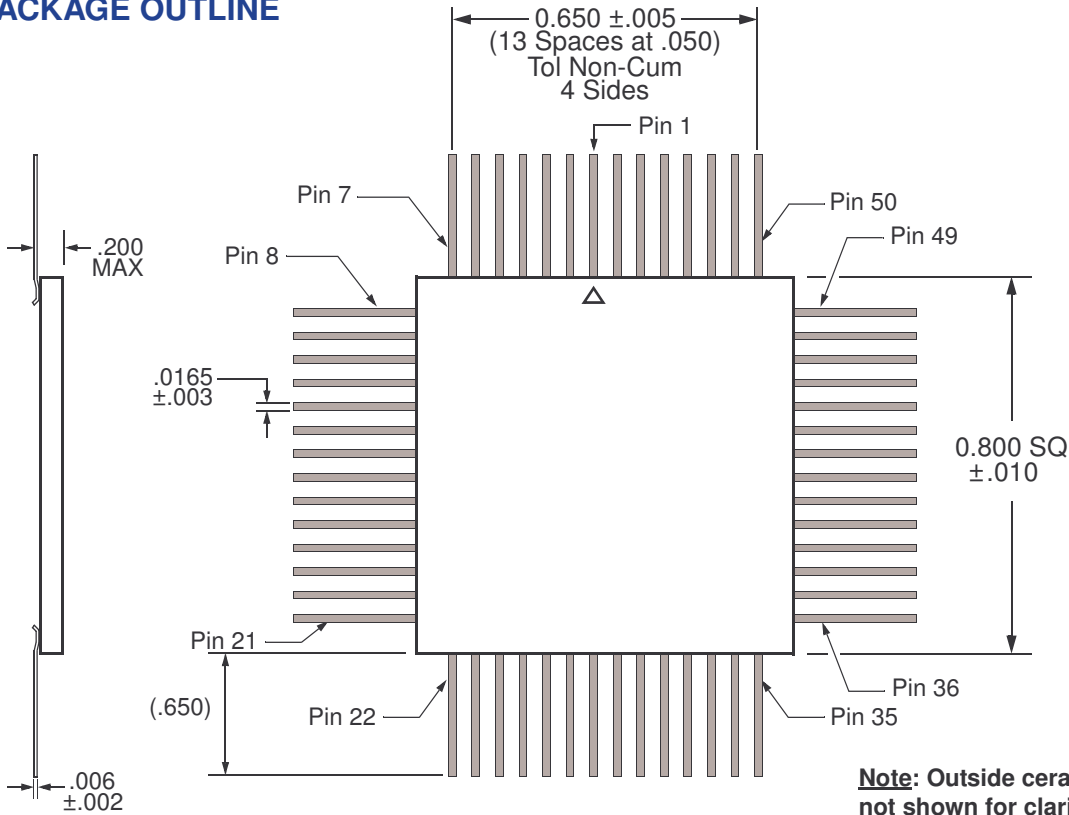

Note: Outside ceramic tie bars not shown for clarity. Contact factory for details.

EXPORT CONTROL:

This product is controlled for export under the International Traffic in Arms Regulations (ITAR). A license from the U.S. Department of State is required prior to the export of this product from the United States.

EXPORT WARNING:

Aeroflex's military and space products are controlled for export under the International Traffic in Arms Regulations (ITAR) and may not be sold or proposed or offered for sale to certain countries. (See ITAR 126.1 for complete information.)

PLAINVIEW, NEW YORK
Toll Free: 800-THE-1553
Fax: 516-694-6715

INTERNATIONAL
Tel: 805-778-9229
Fax: 805-778-1980

NORTHEAST
Tel: 603-888-3975
Fax: 603-888-4585

SE AND MID-ATLANTIC
Tel: 321-951-4164
Fax: 321-951-4254

WEST COAST
Tel: 949-362-2260
Fax: 949-362-2266

CENTRAL
Tel: 719-594-8017
Fax: 719-594-8468

www.aeroflex.com info-ams@aeroflex.com

Aeroflex Microelectronic Solutions reserves the right to change at any time without notice the specifications, design, function, or form of its products described herein. All parameters must be validated for each customer's application by engineering. No liability is assumed as a result of use of this product. No patent licenses are implied.



Our passion for performance is defined by three attributes represented by these three icons: solution-minded, performance-driven and customer-focused