

Standard Products

ACT4461D Single Supply Dual Transceivers for MIL-STD-1553

www.aeroflex.com/Avionics

October 11, 2004



FEATURES

- Small size, light weight and low standby power dual transceiver
- Dual transceiver meets military data bus requirements, MIL-STD-1553 and MIL-STD-1760
- Low power dissipation at full output power
- Single +5V power supply
- Current source output
- Monolithic construction
- Processed and screened to MIL-STD-883 specs
- MIL-PRF-38534 compliant devices available
- Aeroflex-Plainview is a Class H & K MIL-PRF-38534 manufacturer
- DESC SMD# 5962-92061 pending

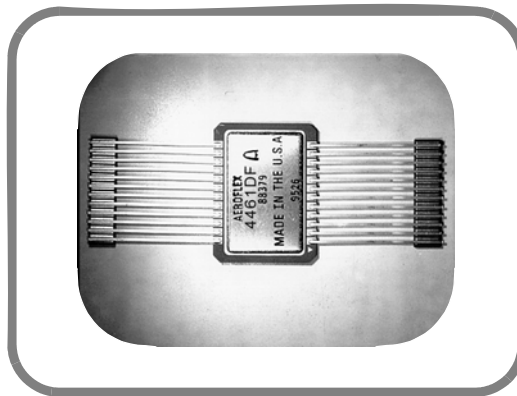

ACT4461DF

Case Style

Actual Size

GENERAL DESCRIPTION

The Aeroflex-Plainview Model ACT4461D is a next generation transceiver which provide full compliance with MIL-STD-1553/1760 and data bus requirements in the smallest package with the lowest standby power consumption and one power supply operation.

The dual channel Model ACT4461D perform the front-end analog function of inputting and outputting data through a transformer to a MIL-STD-1553/1760 data bus. Design of these transceivers reflects particular attention to active filter performance. This results in low bit and word error rate with superior waveform purity and minimal zero crossover distortion. Efficient transmitter electrical and thermal design provides low internal power dissipation and heat rise at high as well as low duty cycles.

Each channel of the dual transceiver is completely separate from the other and fully independent. This includes power leads as well as signal lines. Hence, each channel may be connected to a different data bus with no interaction.

TRANSMITTER

The Transmitter section accepts bi-phase TTL data at the input and when coupled to the data bus with a 1:2.5 transformer, isolated on the data bus side with two 52.5 Ohm fault isolation resistors, and loaded by two 70 Ohm terminations plus additional receivers, the data bus signal produced is 7.5Volts nominal P-P at A-A' (See Figure 5). When both DATA and $\overline{\text{DATA}}$ inputs are held low, the transmitter output becomes a high impedance and is "removed" from the line. In addition, an overriding "INHIBIT" input provides for the removal of the transmitter output from the line. A logic "1" applied to the "INHIBIT" takes priority over the condition of the data inputs and disables the transmitter (See Transmitter Logic Waveform, Figure 1).

The transceiver utilizes an active filter to suppress harmonics above 1MHz. The Transmitter may be safely operated at 100% duty cycle for an indefinite period into a short circuited 1553 bus.

RECEIVER

The Receiver section accepts bi-phase differential data at the input and produces two TTL signals at the output. The outputs are DATA and $\overline{\text{DATA}}$, and represent positive and negative excursions of the input beyond a pre-determined threshold (See Receiver Logic Waveform, Figure 2).

The pre-set internal thresholds will detect data bus signals exceeding 1.150 Volts P-P and reject signals less than 0.6 volts P-P when used with a 1:2.5 turns ratio transformer (See Figure 5 for transformer data and typical connection).

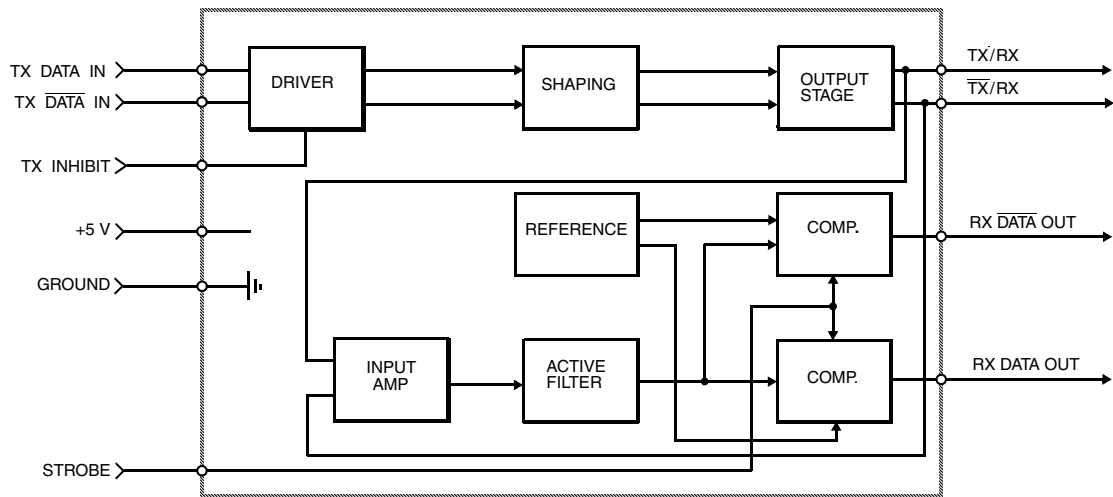

BLOCK DIAGRAM (WITHOUT TRANSFORMER) 1/2 OF UNIT SHOWN

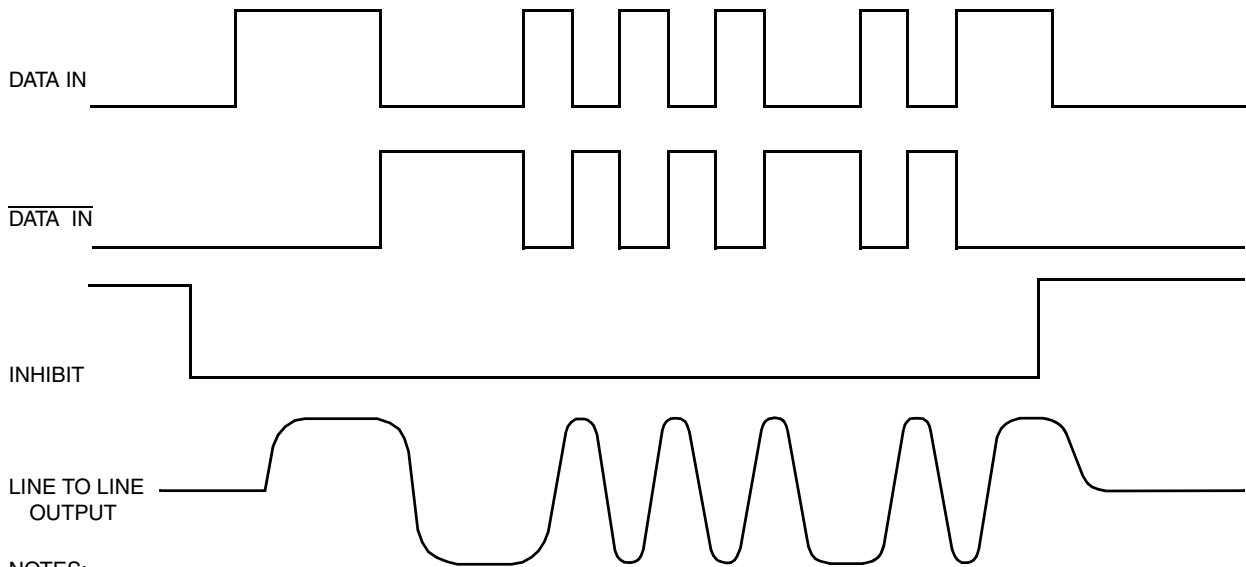

NOTES:

1. DATA and $\overline{\text{DATA}}$ inputs must be complementary waveforms or 50% duty cycle average, with no delays between them.
2. DATA and $\overline{\text{DATA}}$ must be in the same state during off time (both low).

FIGURE 1 – TRANSMITTER LOGIC WAVEFORMS

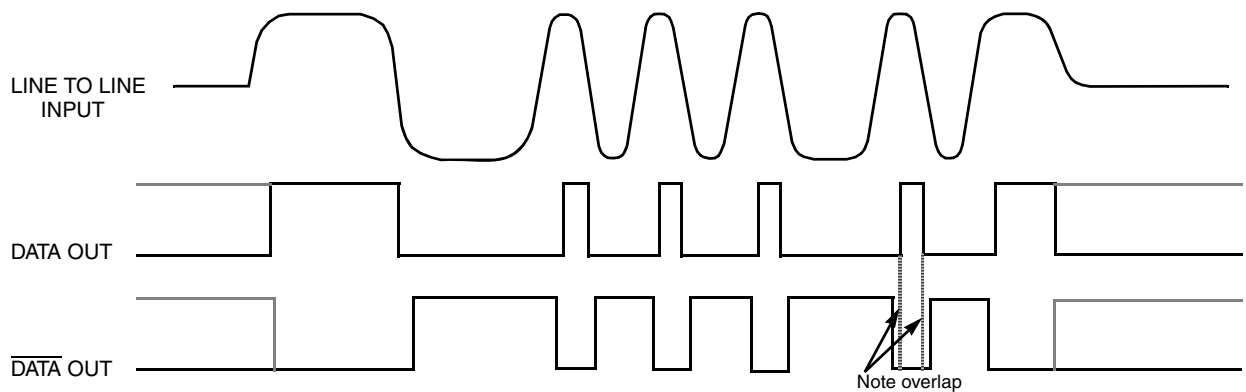

NOTE: Waveforms shown are for normally low devices. For normally high receiver output level devices, the receiver outputs are swapped as shown by the dashed lines.

FIGURE 2 – RECEIVER LOGIC WAVEFORMS

ABSOLUTE MAXIMUM RATINGS

Operating Case Temperature	-55°C to +125°C
Storage Case Temperature	-65°C to +150°C
Power Supply Voltages	-0.3V _{DC} to +7.0V _{DC}
Receiver Differential Input	±10 V
Receiver Input Voltage (Common Mode)	±5V
Driver Peak Output Current	650 mA
Total Package Power Dissipation over the Full Operating Case Temperature Range	2.0 Watts (Note: Normal operation conditions require one transmitter on and the other off at any given time)
Maximum Junction to Case Temperature (100% duty cycle)	10°C
Junction-Case, Thermal Resistance	5°C/W

ELECTRICAL CHARACTERISTICS – DRIVER SECTION 2/ 3/ 4/

INPUT CHARACTERISTICS, TX DATA IN OR TX DATA IN

Parameter	Condition	Symbol	Min	Typ	Max	Unit
"0" Input Current	V _{IN} = 0.4V	I _{ILD}	-	-0.2	-0.4	mA
"1" Input Current	V _{IN} = 2.7V	I _{IHD}	-	1	40	μA
"0" Input Voltage		V _{ILD}	-	-	0.7	V
"1" Input Voltage		V _{IHD}	2.0	-	-	V

INHIBIT CHARACTERISTICS

"0" Input Current	V _{IN} = 0.4V	I _{ILI}	-	-0.2	-0.4	mA
"1" Input Current	V _{IN} = 2.7V	I _{IHI}	-	1.0	40	μA
"0" Input Voltage		V _{ILI}	-	-	0.7	V
"1" Input Voltage		V _{IHI}	2	-	-	V
Delay from TX inhibit, (0→1) to inhibited output		t _{DXOFF}	-	200	300	nS
Delay from TX inhibit, (1→0) to active output		t _{DXON}	-	80	180	nS
Differential Output Noise, inhibit mode		V _{NOI}	-	2	10	mV p-p
Differential Output Impedance (inhibited)	Note 1	Z _{OI}	2K	-	-	Ω

OUTPUT CHARACTERISTICS

Differential output level	R _L = 35 Ω	V _O	6.5	7.5	8.0	V p-p
Rise and fall times (10% to 90% of p-p output)		t _r	100	170	300	nS
Output offset at point A-A' on Figure 5, 2.5 μS after midpoint crossing of the parity bit of the last word of a 600μS message	R _L = 35 Ω	V _{OS}	-	-	±90	mV peak
Delay from 50% point of TX DATA or TX DATA input to zero crossing of differential signal		t _{DTX}	-	100	180	nS

ELECTRICAL CHARACTERISTICS – RECEIVER SECTION 2/ 3/ 4/

Parameter	Condition	Symbol	Min	Typ	Max	Unit
Differential Voltage Range, Figure 4 Point P-P'		V_{IDR}	-	-	20	V p-p
Common Mode Rejection Ratio		CMRR	45	-	-	dB

STROBE CHARACTERISTICS (LOGIC "0" INHIBITS OUTPUT) If not used, a 1K pullup to 5V is recommended

"0" Input Current	$V_S = 0.4V$	I_{IL}	-	-0.2	-0.4	mA
"1" Input Current	$V_S = 2.7V$	I_{IH}	-	1	+40	μA
"0" Input Voltage		V_{IL}	-	-	0.7	V
"1" Input Voltage		V_{IH}	2.0	-	-	V
Strobe Delay (turn-on)		$t_{SD(ON)}$	-	40	100	nS
Strobe Delay (turn-off)		$t_{SD(OFF)}$	-	60	100	nS

THRESHOLD CHARACTERISTICS (SINEWAVE INPUT)

Internal Threshold Voltage (Referred to the bus)	100KHz-1MHz	V_{TH}	0.60	0.80	1.15	V p-p
--	-------------	----------	------	------	------	-------

OUTPUT CHARACTERISTICS, RX DATA AND RX \overline{DATA}

"1" State	$I_{OH} = -0.4mA$	V_{OH}	2.5	3.7	-	V
"0" State	$I_{OL} = 4mA$	V_{OL}	-	0.3	0.5	V
Delay, (average) from differential input zero crossings to RX DATA and RX \overline{DATA} output	50% points	t_{DRX}	-	250	400	nS

POWER DATA 2/ 3/ 4/

MAXIMUM CURRENTS, PER CHANNEL (+5V)

Duty Cycle	Typ	Max
Transmitter Standby	20 mA	30 mA
25% duty cycle	155 mA	185 mA
50% duty cycle	290 mA	335 mA
100% duty cycle	560 mA	650 mA

POWER SUPPLY VOLTAGE

+V	4.75 to 5.5 Volts
----	-------------------

NOTES:

1. Power ON/OFF, measured from 75KHz to 1MHz at Point A-A. See Figure 5.
2. $V_{CC} = 5$ Volts ± 0.1 V, for all measurements unless otherwise specified.
3. Specifications apply over the case temperature range of -55°C to +125°C unless otherwise specified.
4. All typical values are measured at +25°C.

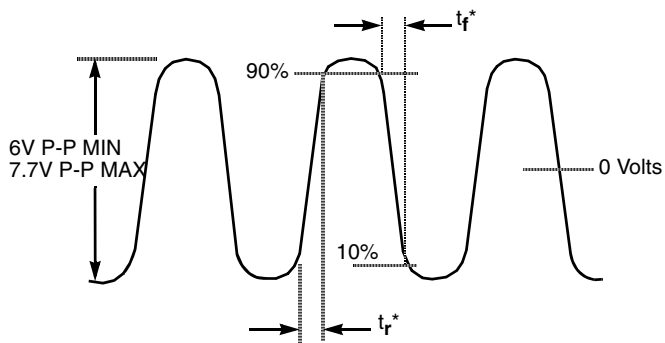

* Rise and fall times measured at point A-A' in Fig 5

FIGURE 3 – TRANSMITTER (TX) OUTPUT WAVEFORM

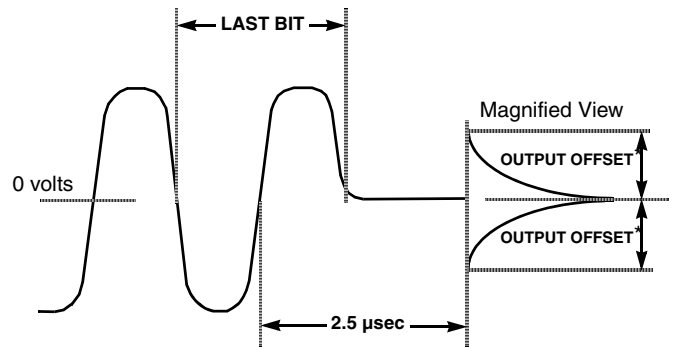

*Offset measured at point A-A' in Fig 5

FIGURE 4 – TRANSMITTER (TX) OUTPUT OFFSET

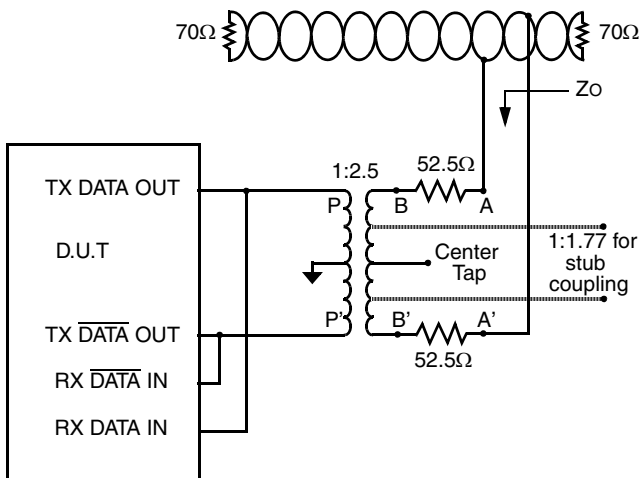
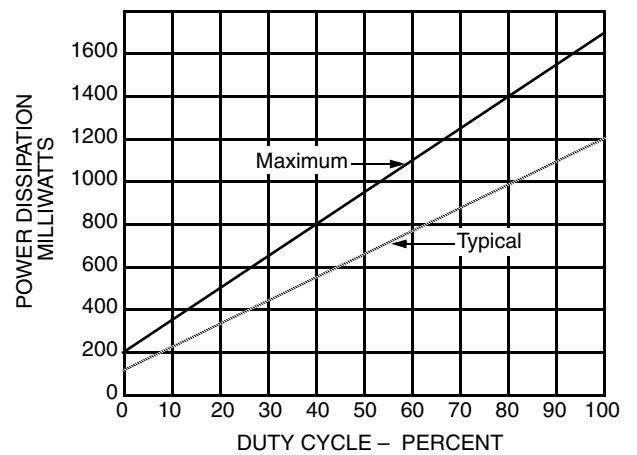

FIGURE 5 – TYPICAL TRANSFORMER CONNECTION



Note: $V_{cc} = 5$ Volts, V_{bus} (pt A-A') at 7.5 Volts P-P

FIGURE 6 – POWER DISSIPATION VS. DUTY CYCLE
(Total, hybrid with one channel transmitting and the other not powered)

PIN NUMBERS & FUNCTIONS

Pin #	Function	Channel
1	TX DATA OUT/RX DATA IN	A
2	TX $\overline{\text{DATA}}$ OUT/RX $\overline{\text{DATA}}$ IN	A
3	GROUND 1	A
4	RX DATA OUT	A
5	STROBE	A
6	RX $\overline{\text{DATA}}$ OUT	A
7	TX DATA OUT/RX DATA IN	B
8	TX $\overline{\text{DATA}}$ OUT/RX $\overline{\text{DATA}}$ IN	B
9	GROUND 1	B
10	RX DATA OUT	B
11	STROBE	B
12	RX $\overline{\text{DATA}}$ OUT	B
13	GROUND 2	B
14	+5V	B
15	GROUND 3	B
16	INHIBIT	B
17	TX DATA IN	B
18	TX $\overline{\text{DATA}}$ IN	B
19	GROUND 2	A
20	+5V	A
21	GROUND 3	A
22	INHIBIT	A
23	TX DATA IN	A
24	TX $\overline{\text{DATA}}$ IN	A

CONFIGURATIONS AND ORDERING INFORMATION

Model No.	DESC No.	Receiver Data level	Configuration
ACT4461DF	5962-92061 (Pending)	Normally Low	Dual
ACT4461DFI		Normally High	

FLAT PACKAGE CONFIGURATION AND PINOUTS

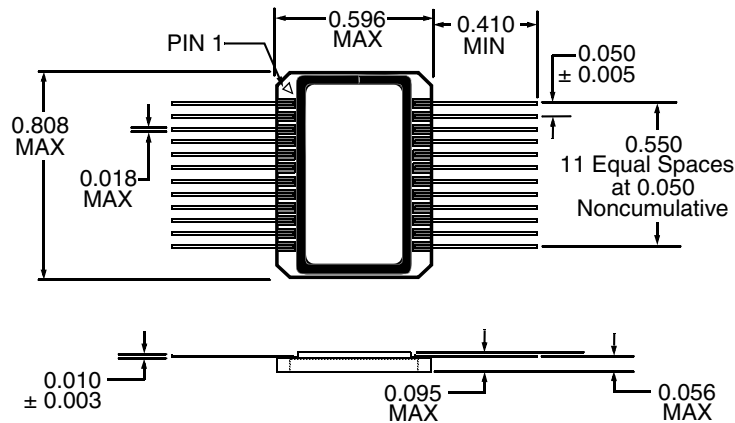

PLAINVIEW, NEW YORK
 Toll Free: 800-THE-1553
 Fax: 516-694-6715

INTERNATIONAL
 Tel: 805-778-9229
 Fax: 805-778-1980

NORTHEAST
 Tel: 603-888-3975
 Fax: 603-888-4585

SE AND MID-ATLANTIC
 Tel: 321-951-4164
 Fax: 321-951-4254

WEST COAST
 Tel: 949-362-2260
 Fax: 949-362-2266

CENTRAL
 Tel: 719-594-8017
 Fax: 719-594-8468

www.aeroflex.com info-ams@aeroflex.com



Aeroflex Microelectronic Solutions reserves the right to change at any time without notice the specifications, design, function, or form of its products described herein. All parameters must be validated for each customer's application by engineering. No liability is assumed as a result of use of this product. No patent licenses are implied.



Our passion for performance is defined by three attributes represented by these three icons: solution-minded, performance-driven and customer-focused