

## Standard Products

# ACT4455/4459 Single Supply Transceiver for MIL-STD-1553/1760 & SAE-AS15531

www.aeroflex.com/Avionics

November 5, 2008



## FEATURES

- Small size, light weight and low standby power single transceiver
- Single +5V power supply
- Monolithic construction
- Outstanding MIL-STD-1553 / SAE-AS15531 performance
- Designed for commercial, industrial and aerospace applications
- Processed and screened to MIL-STD-883 specs
- MIL-PRF-38534 compliant devices
- Aeroflex-Plainview is a Class H & K MIL-PRF-38534 manufacturer
- Packaging – 28-pad Ceramic LCC, Hermetic
- DSCC SMD: 5962-96741 approved

## GENERAL DESCRIPTION

The Aeroflex-Plainview ACT4455/4459 series are next generation monolithic transceiver designs which provide full compliance with MIL-STD-1553A/B, MIL-STD-1760 and SAE-AS15531 requirements in the smallest packages with low power consumption and single power supply operation. The series performs the front-end analog function of inputting and outputting data through a transformer to the MIL-STD-1553 data bus.

Design of these transceivers reflects particular attention to active filter performance. This results in low bit and word error rate with superior waveform purity and minimal zero crossover distortion. Efficient transmitter electrical and thermal design provides low internal power dissipation and heat rise at high as well as low duty cycles. All inputs are internally pulled up to +5 Volts.

## TRANSMITTER

The Transmitter section accepts bi-phase TTL data at the input and when coupled to the data bus with a 1:2.5 ratio transformer the data bus signal is typically 7.5 volts P-P at A-A' (See Figure 5). When both DATA and  $\overline{\text{DATA}}$  inputs are held low or high, the transmitter output becomes a high impedance and is “removed” from the line. In addition, an overriding “INHIBIT” input provides for the removal of the transmitter output from the line. A logic “1” applied to the “INHIBIT” takes priority over the condition of the data inputs and disables the transmitter (See Transmitter Logic Waveform, Figure 1). The Transmitter may be safely operated for an indefinite period with the bus (point A-A') short circuited at 100% duty cycle.

## RECEIVER

The Receiver section accepts bi-phase differential data at the input and produces two TTL signals at the output. The outputs are DATA and  $\overline{\text{DATA}}$ , and represent positive and negative excursions of the input beyond a pre-determined threshold (See Receiver Logic Waveform, Figure 2).

The pre-set internal thresholds will detect data bus signals exceeding 1.20 Volts P-P and reject signals less than 0.6 volts P-P when used with a transformer (See Figure 5 for transformer data and typical connection).

A low level at the Strobe input inhibits the DATA and  $\overline{\text{DATA}}$  outputs.

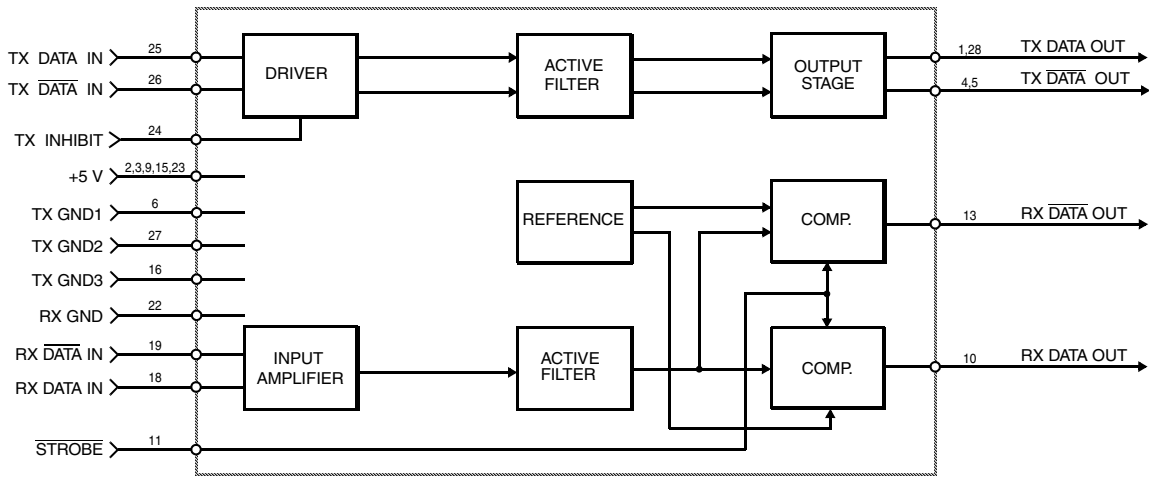

**BLOCK DIAGRAM (WITHOUT TRANSFORMER)**

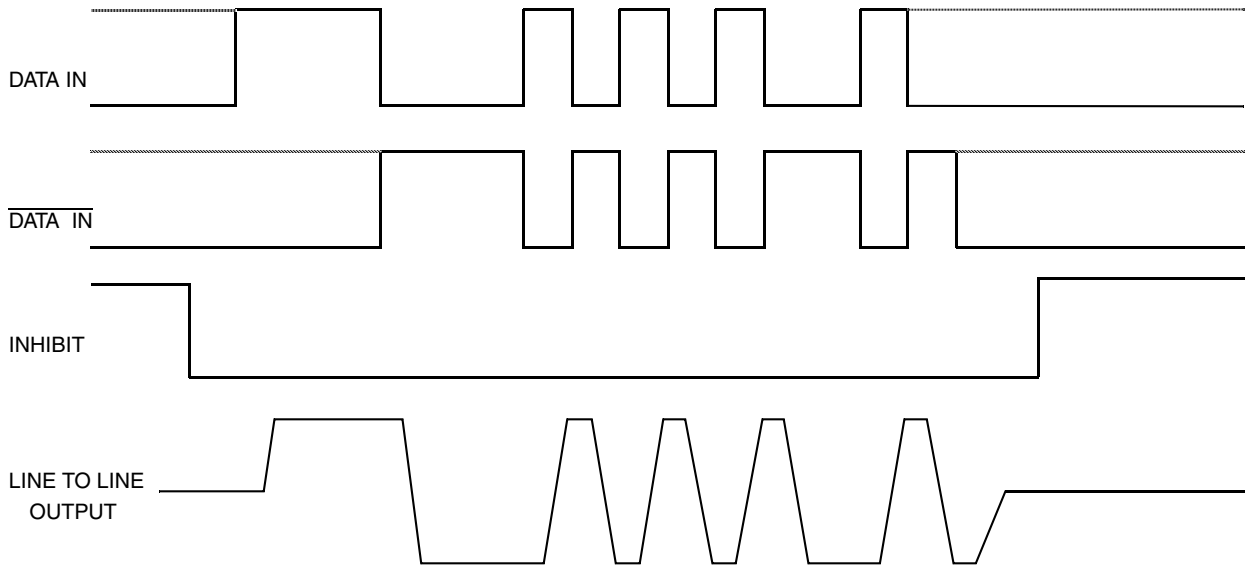

**Note:** DATA and  $\overline{\text{DATA}}$  inputs must be complementary waveforms or 50% duty cycle average, with no delays between them, and must be in the same state during off times (both high or low).

**FIGURE 1 – TRANSMITTER LOGIC WAVEFORMS IDEALIZED \***

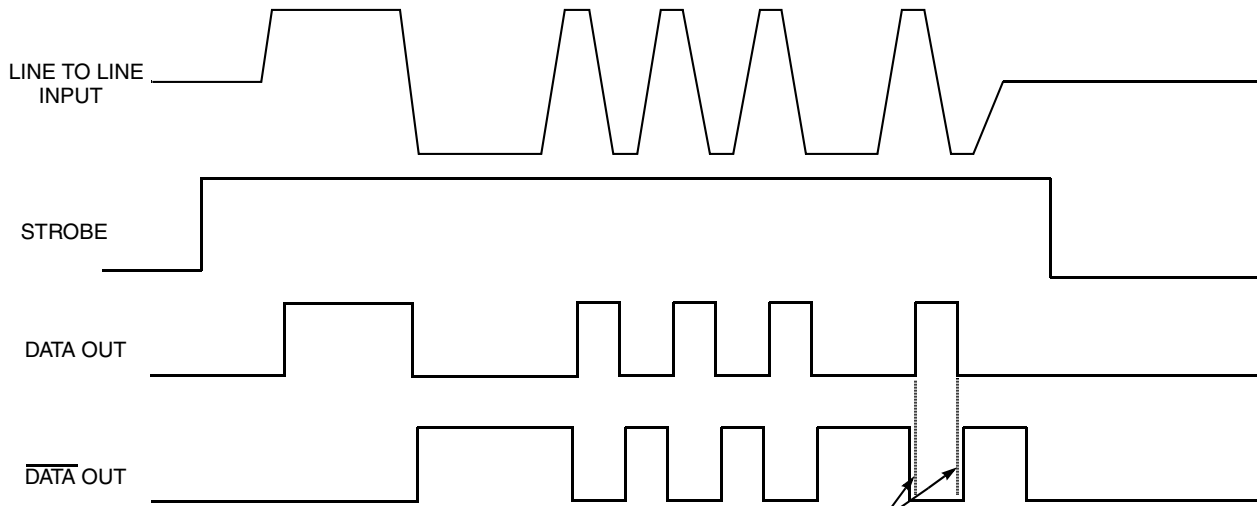

\* See Figure 7 for Actual Waveforms

Note overlap

**FIGURE 2 – RECEIVER LOGIC WAVEFORMS IDEALIZED \***

## ABSOLUTE MAXIMUM RATINGS

Operating case temperature	-55°C to +125°C
Storage case temperature	-65°C to +150°C
Power supply voltage	-0.3V <sub>DC</sub> to +7.0V <sub>DC</sub>
Logic input voltage	-0.3V <sub>DC</sub> to +5.5V <sub>DC</sub>
Receiver differential input	±10 V
Receiver input voltage (common mode)	±5 V
Driver peak output current	1.0 A
Total package power dissipation over the full operating case temperature range	2.0 Watts
Maximum junction to case temperature	10°C
Thermal resistance – Junction to case	5°C/W

## ELECTRICAL CHARACTERISTICS – DRIVER SECTION

### INPUT CHARACTERISTICS, TX DATA IN OR TX DATA IN (Notes 2 & 3 Apply)

Parameter	Condition	Symbol	Min	Typ	Max	Unit
"0" Input Current	V <sub>IN</sub> = 0.4V	I <sub>ILD</sub>	-	-0.2	-0.4	mA
"1" Input Current	V <sub>IN</sub> = 2.7V	I <sub>IHD</sub>	-	1	40	μA
"0" Input Voltage		V <sub>ILD</sub>	-	-	0.7	V
"1" Input Voltage		V <sub>IHD</sub>	2.0	-	-	V

### INHIBIT CHARACTERISTICS

"0" Input Current	V <sub>IN</sub> = 0.4V	I <sub>ILI</sub>	-	-0.2	-0.4	mA
"1" Input Current	V <sub>IN</sub> = 2.7V	I <sub>IHI</sub>	-	1.0	40	μA
"0" Input Voltage		V <sub>ILI</sub>	-	-	0.7	V
"1" Input Voltage		V <sub>IHI</sub>	2	-	-	V
Delay from TX inhibit, (0→1) to inhibited output		t <sub>DXOFF</sub>	-	250	450	nS
Delay from TX inhibit, (1→0) to active output		t <sub>DXON</sub>	-	150	250	nS
Differential Output Noise, inhibit mode		V <sub>NOI</sub>	-	2	10	mV <sub>p-p</sub>
Differential Output Impedance (inhibited)	Note 1	Z <sub>OI</sub>	2K	-	-	Ω

### OUTPUT CHARACTERISTICS

Differential output level	R <sub>L</sub> = 35 Ω	V <sub>O</sub>	6.5	7.5	9	V <sub>p-p</sub>
Rise and fall times (10% to 90% of p-p output)		t <sub>r</sub>	100	200	300	nS
Output offset at point A-A' on Figure 5, 2.5 μS after midpoint crossing of the parity bit of the last word of a 660μS message	R <sub>L</sub> = 35 Ω	V <sub>OS</sub>	-	-	±90	mV <sub>peak</sub>
Delay from 50% point of TX DATA or TX DATA input to zero crossing of differential signal		t <sub>DTX</sub>	-	120	250	nS

## ELECTRICAL CHARACTERISTICS – RECEIVER SECTION

Parameter	Condition	Symbol	Min	Typ	Max	Unit
Differential Voltage Range (See Figure 5, point P-P')	TXFMR 2.5:1	$V_{IDR}$	-	14	20	V <sub>p-p</sub>
Common Mode Rejection Ratio (Note 3)		CMRR	45	-	-	dB

### STROBE CHARACTERISTICS (LOGIC "0" INHIBITS OUTPUT)

"0" Input Current	$V_S = 0.4V$	$I_{IL}$	-	-0.2	-0.4	mA
"1" Input Current	$V_S = 2.7V$	$I_{IH}$	-	1	+40	$\mu A$
"0" Input Voltage		$V_{IL}$	-	-	0.7	V
"1" Input Voltage		$V_{IH}$	2.0	-	-	V
Strobe Delay (Turn-on or Turn-off)		$t_{SD}$	-	50	200	nS

### THRESHOLD CHARACTERISTICS (SINEWAVE INPUT)

Internal Threshold Voltage (Referred to the bus)	100KHz-1MHz	$V_{TH}$	0.56	0.82	1.10	V <sub>p-p</sub>
--	-------------	----------	------	------	------	------------------

### OUTPUT CHARACTERISTICS, RX DATA AND $\overline{RX DATA}$

"1" State	$I_{OH} = -0.4mA$	$V_{OH}$	2.5	3.7	-	V
"0" State	$I_{OL} = -4mA$	$V_{OL}$	-	0.35	0.5	V
Delay, (average) from differential input zero crossings to RX DATA and $\overline{RX DATA}$ output	50% points	$t_{DRX}$	-	340	500	nS

## POWER DATA

### POWER SUPPLY CURRENTS – PER CHANNEL

Transmitter Standby	(Note 4)	$I_{CC}$	-	18	30	mA
25% Duty Cycle			-	150	220	
50% Duty Cycle			-	300	395	
100% Duty Cycle			-	600	745	

### POWER SUPPLY VOLTAGE

Operating Power Supply Voltage Range		$V_{CC}$	+4.75	+5.00	+5.50	V
--------------------------------------	--	----------	-------	-------	-------	---

#### NOTES:

- Power on or off, measured from 75KHz to 1MHz at point A-A' and transformer self impedance of 3K $\Omega$  minimum.
- $V_{CC} = 5$  Volts  $\pm 0.1$  V, bypassed by 2.2  $\mu F$  (Tantalum recommended) Capacitor minimum. All measurements & specifications apply over the temperature range of -55°C to +125°C (case temperature) unless otherwise specified.
- When measured at point A-A' with  $\pm 10$  Volt peak, line to ground, DC to 2MHz.
- Typical power is measured with  $V_{bus}$  at point A-A' = 7.5 V<sub>p-p</sub>.

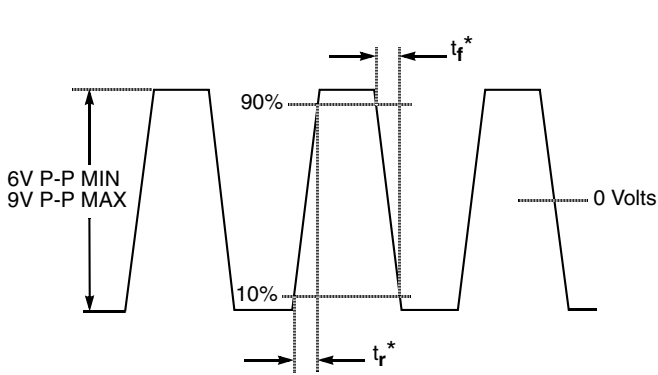

\* Rise and fall times measured at point A-A' in Figure 5

**FIGURE 3 – TRANSMITTER (TX) OUTPUT WAVEFORM**

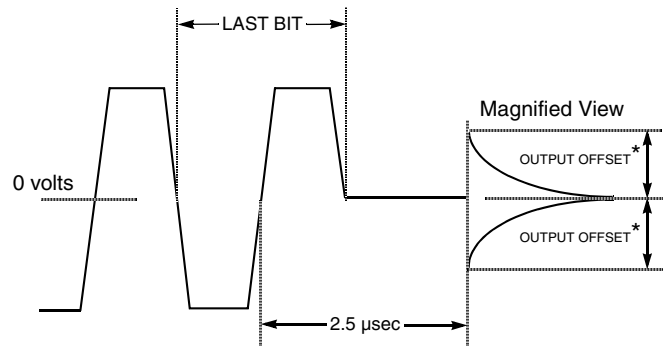

\*Offset measured at point A-A' in Figure 5

**FIGURE 4 – TRANSMITTER (TX) OUTPUT OFFSET**

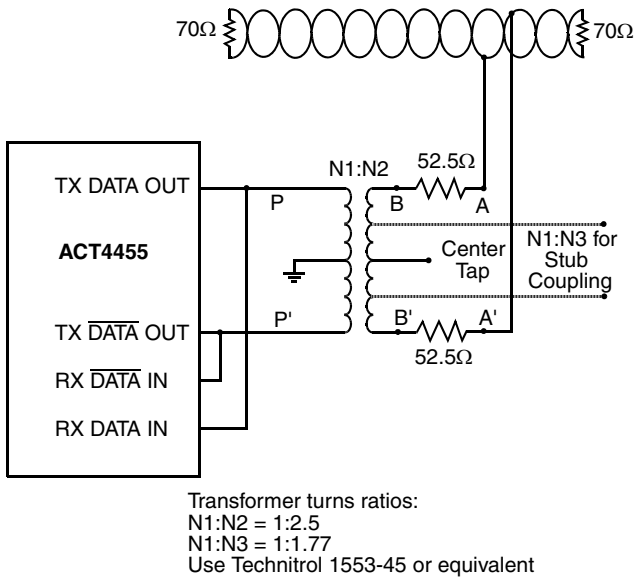

**FIGURE 5 – TYPICAL TRANSFORMER DIRECT CONNECTION**

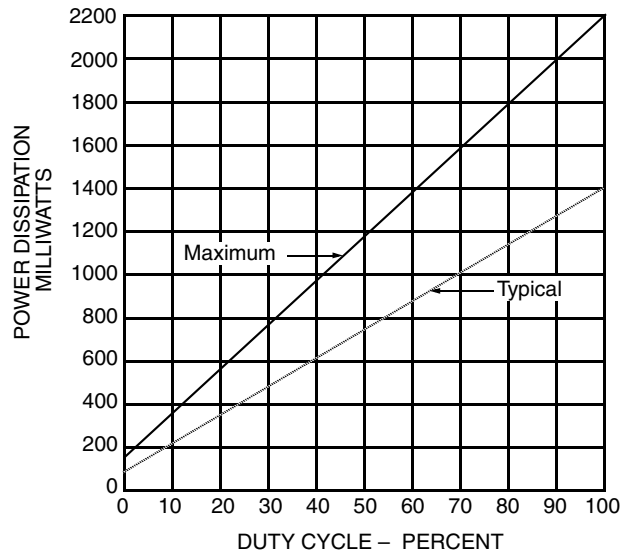

Note:  $V_{cc} = 5V_{dc}$ , Transformer ratio 1:2.5,  $V_{BUS}$  (pt A-A') at 7.5Vp-p

**FIGURE 6 – POWER DISSIPATION VS. DUTY CYCLE**

**START OF WORD – 33 WORD TRANSMISSION**

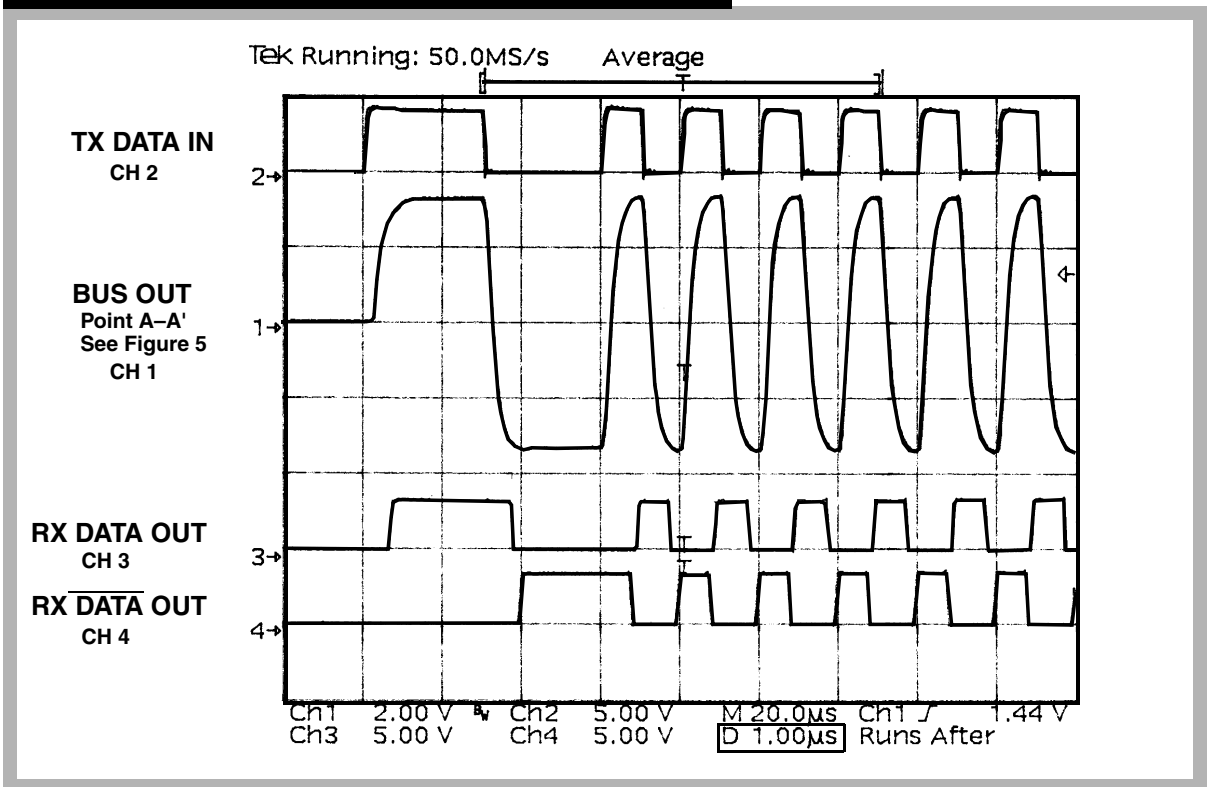

**END OF WORD – 33 WORD TRANSMISSION**

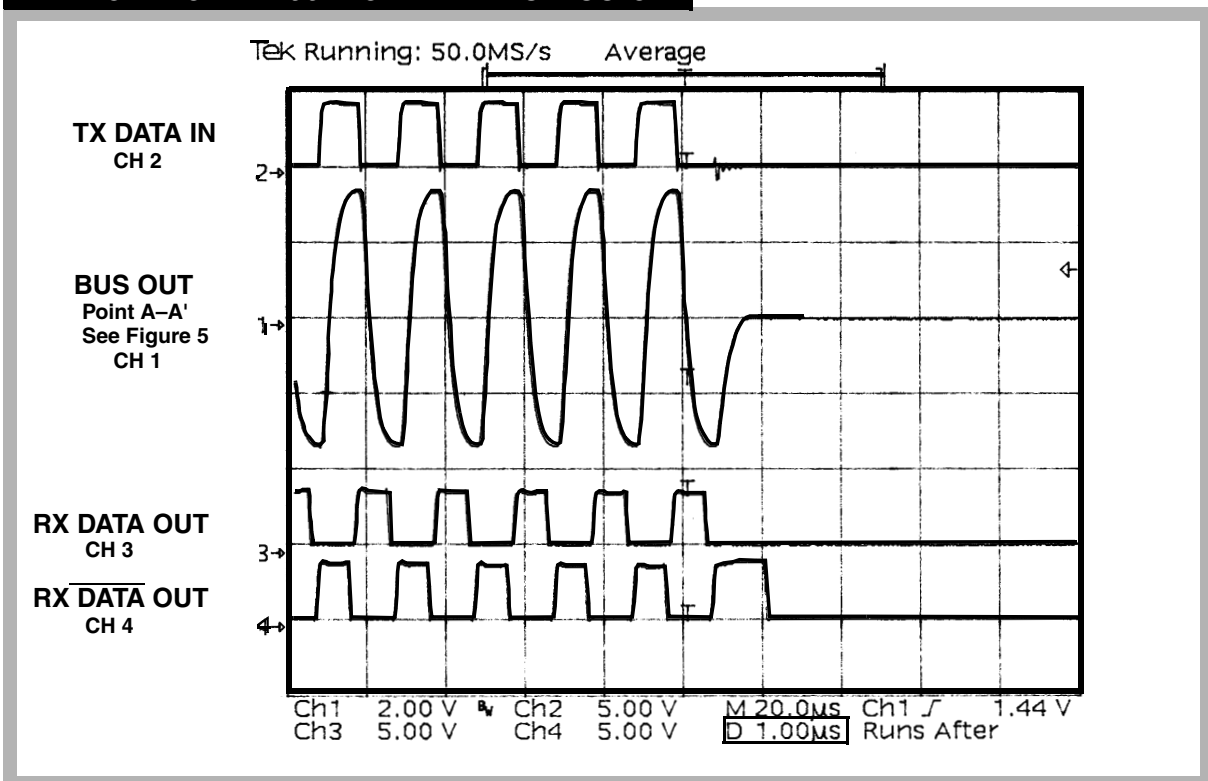

\* Oscilloscope used is a TEK TDS540 with Probe 6139A.

**FIGURE 7 ACTUAL HYBRID WAVEFORMS \* – 25°C TYPICAL**

## LCC LEADLESS CHIP CARRIER PACKAGE CONFIGURATION

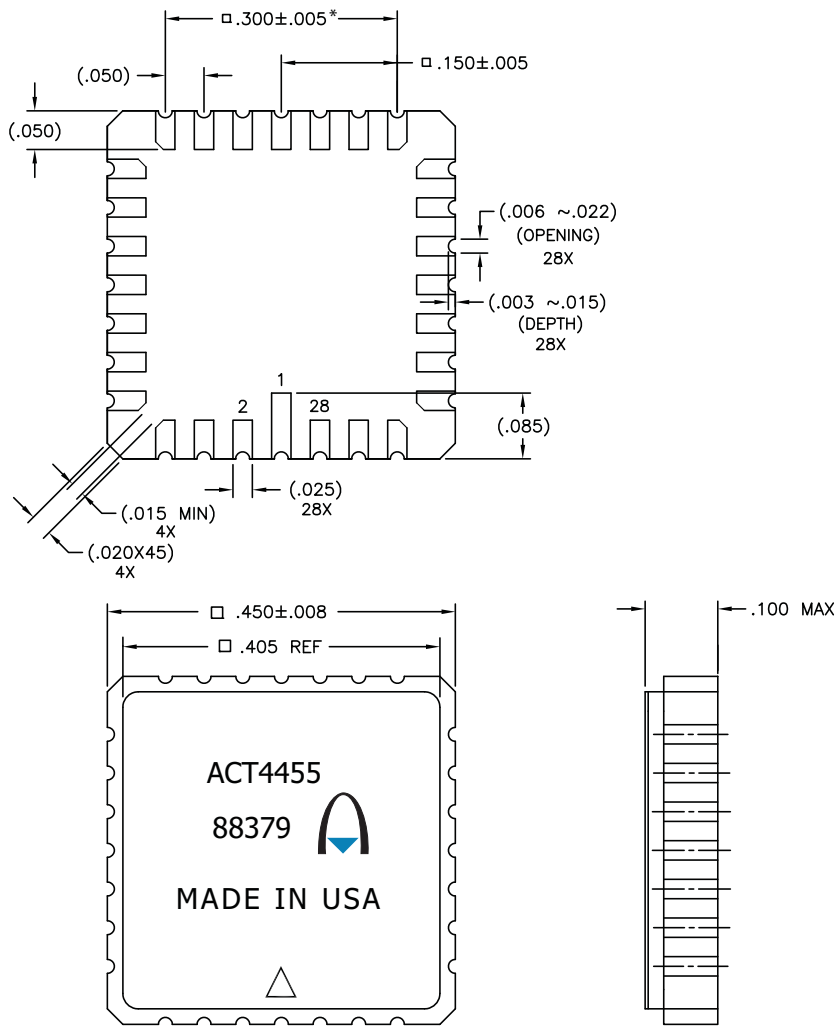

\* NOTE: Castellation spacing .050 x6, Tol. Non-Accumulative

### PIN NUMBERS & FUNCTIONS

Pin #	Function	Pin #	Function
1	TX DATA OUT	15	+5V
2	+5V	16	TX GND3 **
3	+5V	17	NC
4	TX $\overline{\text{DATA}}$ OUT	18	RX DATA IN
5	TX $\overline{\text{DATA}}$ OUT	19	RX $\overline{\text{DATA}}$ IN
6	TX GND1 **	20	NC
7	NC	21	NC
8	NC	22	RX GND **
9	+5V	23	+5V
10	RX DATA OUT	24	TX INHIBIT
11	$\overline{\text{STROBE}}$	25	TX DATA IN
12	NC	26	TX $\overline{\text{DATA}}$ IN
13	RX $\overline{\text{DATA}}$ OUT	27	TX GND2 **
14	NC	28	TX DATA OUT

\*\* NOTE: Grounds not Internally connected

## ORDERING INFORMATION

MODEL #	DSCC SMD #	SCREENING	RECEIVER DATA LEVEL
ACT4455	-	Military Temperature, -55°C to +125°C Screened in accordance with MIL-PRF-38534, Class H.	Normally Low
ACT4455-001-1	5962-9674101H3C	In accordance with DSCC SMD 5962-96741	Normally Low
ACT4455-001-2	5962-9674101H3A		
ACT4459-001-1	5962-9674102H3C	In accordance with DSCC SMD 5962-96741	Normally High
ACT4459-001-2	5962-9674102H3A		

**PLAINVIEW, NEW YORK**

Toll Free: 800-THE-1553  
Fax: 516-694-6715

**INTERNATIONAL**

Tel: 805-778-9229  
Fax: 805-778-1980

**NORTHEAST**

Tel: 603-888-3975  
Fax: 603-888-4585

**SE AND MID-ATLANTIC**

Tel: 321-951-4164  
Fax: 321-951-4254

**WEST COAST**

Tel: 949-362-2260  
Fax: 949-362-2266

**CENTRAL**

Tel: 719-594-8017  
Fax: 719-594-8468

*www.aeroflex.com    info-ams@aeroflex.com*



Aeroflex Microelectronic Solutions reserves the right to change at any time without notice the specifications, design, function, or form of its products described herein. All parameters must be validated for each customer's application by engineering. No liability is assumed as a result of use of this product. No patent licenses are implied.



Our passion for performance is defined by three attributes represented by these three icons: solution-minded, performance-driven and customer-focused