

## Standard Products

# ARX4404 & ARX4407 Transceiver

for MACAIR (A3818, A4905, A5232, A5690), MIL-STD-1553  
& SAE-AS15531

[www.aeroflex.com/Avionics](http://www.aeroflex.com/Avionics)

April 5, 2005



## FEATURES

- ARX4404 Transceiver meets Macair (A3818, A4905, A5232 and A5690) & MIL-STD-1553A/B
- ARX4407 Transceiver meets MIL-STD-1553 and SAE-AS15531
- Bipolar supply  $\pm 15V$  to  $\pm 12V$ , Logic supply +5VDC
- Direct replacement for CT3231 and CT3232
- Variable receiver threshold capability
- Monolithic construction
- Voltage source output for higher bus drive power
- Low receiver data level versions: ARX4440 and ARX4467
- Designed for commercial, industrial and aerospace applications
- MIL-PRF-38534 compliant devices available
- Aeroflex-Plainview is a Class H & K MIL-PRF-38534 manufacturer
- DESC SMD 5962-91749

## GENERAL DESCRIPTION

The Aeroflex Plainview transceiver model ARX4404 and is a new generation monolithic transceiver which provide full compliance with Macair and MIL-STD-1553 data bus requirements. The model ARX4404 and ARX4407 performs the front-end analog function of inputting and outputting data through a transformer to a MIL-STD-1553 or Macair data bus.

The ARX4404 can be considered a "Universal" Transceiver in that it is compatible with Macair (A-3818, A-4905, A-5232 and A-5690), MIL-STD-1553A/B and SAE-AS1553. The ARX4407 is compatible with MIL-STD-1553A/B and SAE-AS15531.

Design of these transceivers reflects particular attention to active filter performance. This results in low bit and word error rate with superior waveform purity and minimal zero crossover distortion. The ARX4404 active filter design has additional high frequency roll-off to provide the required Macair low harmonic distortion waveform without increasing the pulse delay characteristics significantly.

Efficient transmitter electrical and thermal design provides low internal power dissipation and heat rise at high and low duty cycles. An optional receiver input threshold adjustment can be accomplished by the use of the "External Threshold" terminals or use of the "Set Internal Threshold" terminals.

## TRANSMITTER

The Transmitter section accepts bi-phase TTL data at the input and when coupled to the data bus with a 1:1 transformer the data bus signal produced is 7.0 Volts minimum P-P at point A-A' (See Figure 5). When both DATA and  $\overline{\text{DATA}}$  inputs are held low or high, the transmitter output becomes a high impedance and is "removed" from the line. In addition, an overriding "INHIBIT" input provides for the removal of the transmitter output from the line. A logic "1" applied to the "INHIBIT" takes priority over the condition of the data inputs and disables the transmitter (See Transmitter Logic Waveforms - Figure 1).

The transmitter utilizes an active filter to suppress harmonics above 1 MHz to meet Macair specifications A-3818, A-4905, A-5232 and A-5690. The transmitter may be safely operated for an indefinite period at 100% duty cycle into a data bus short circuit.

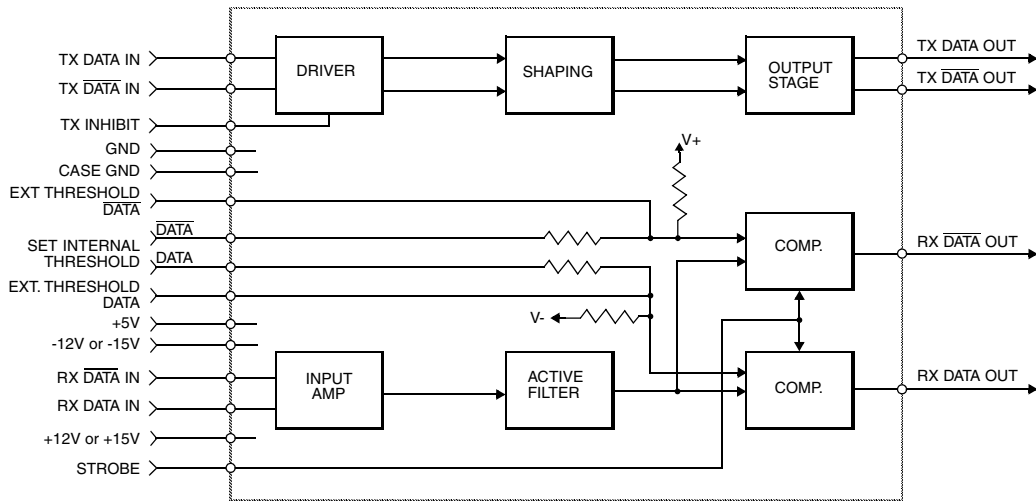
The transceiver utilizes an active filter to suppress harmonics above 1MHz. The Transmitter may be safely operated at 100% duty cycle for an indefinite period into a short circuited 1553 bus.

## RECEIVER

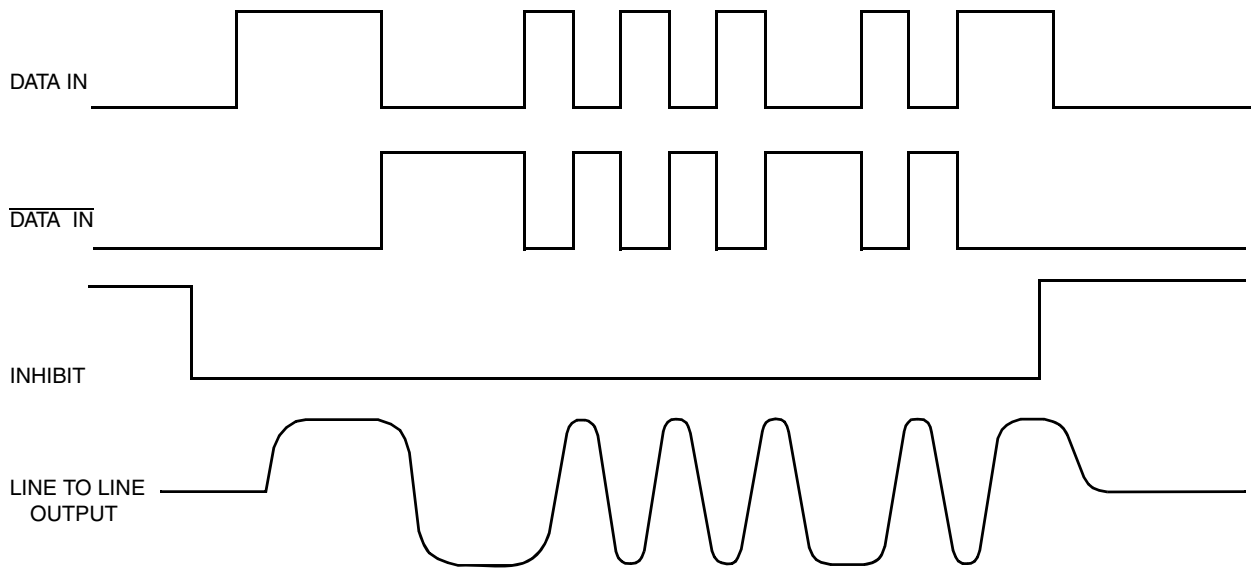
The Receiver section accepts bi-phase differential data at the input and produces two TTL signals at the output. The outputs are DATA and  $\overline{\text{DATA}}$ , and represent positive and negative excursions of the input beyond a pre-determined threshold (See Receiver Logic Waveforms - Figure 2).

The internal threshold is nominally set to detect data bus signals exceeding 1.05 Vp-p and reject signals less than 0.6 Vp-p when used with a 1:1 turns ratio transformer (See Figure 3 or 4 for transformer data and typical connection). This threshold setting can be held by grounding the appropriate pins or modified with the use of external resistors.

A low level at the "STROBE" input inhibits the DATA and  $\overline{\text{DATA}}$  outputs. If unused, a 2K Ohm pull-up to +5VDC is recommended.

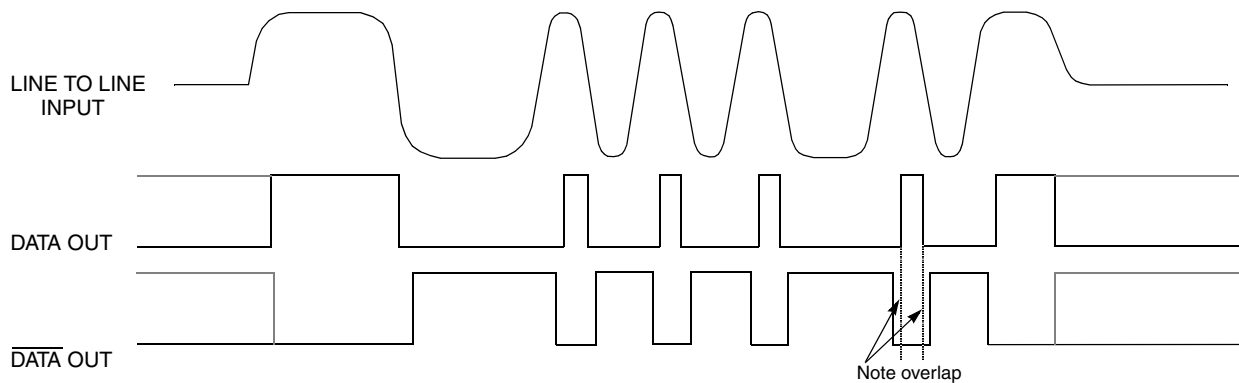


**BLOCK DIAGRAM (WITHOUT TRANSFORMER)**



- Notes:
1. Line to line waveforms illustrate Macair signals, MIL-STD-1553 signals are trapezoidal.
  2. DATA and  $\overline{\text{DATA}}$  inputs must be complementary waveforms or 50% duty cycle average, with no delays between them.
  3. DATA and  $\overline{\text{DATA}}$  must be in the same state during off time (both high or low).

**FIGURE 1 – TRANSMITTER LOGIC WAVEFORMS IDEALIZED**



Note: Waveforms shown are for normally low devices. For normally high receiver output level devices, the receiver outputs are swapped as shown by the dashed lines

**FIGURE 2 – RECEIVER LOGIC WAVEFORMS IDEALIZED**

## ABSOLUTE MAXIMUM RATINGS

Operating Case Temperature	-55°C to +125°C	
Storage Case Temperature	-65°C to +150°C	
Power Supply Voltages	±15VDC to ±18VDC	+5VDC to +7VDC
Logic Input Voltage	-0.3 V to +5.5 V	
Receiver Differential Input	±40 V	
Receiver Input Voltage (Common Mode)	±10V	
Driver Peak Output Current	300 mA	
Total Package Power Dissipation over the Full Operating Case Temperature Range	2.4 Watts	
Power Dissipation for hottest die, (100% duty cycle)	600 mW	
Maximum junction to case temperature rise for the hottest device (100 % duty cycle)	36°C	
Junction-Case, Thermal Resistance for hottest device	60°C/W	

## ELECTRICAL CHARACTERISTICS – TRANSMITTER SECTION

### INPUT CHARACTERISTICS, TX DATA IN OR TX DATA IN

Parameter	Condition	Symbol	Min	Typ	Max	Unit
"0" Input Current	$V_{IN} = 0.4V$	$I_{ILD}$	-	-0.2	-0.4	mA
"1" Input Current	$V_{IN} = 2.7V$	$I_{IHD}$	-	1	40	μA
"0" Input Voltage	-	$V_{ILD}$	-	-	0.7	V
"1" Input Voltage	-	$V_{IHD}$	2.0	-	-	V

### INHIBIT CHARACTERISTICS

"0" Input Current	$V_{IN} = 0.4V$	$I_{ILI}$	-	-0.2	-0.4	mA
"1" Input Current	$V_{IN} = 2.7V$	$I_{IHI}$	-	1.0	40	μA
"0" Input Voltage	-	$V_{ILI}$	-	-	0.7	V
"1" Input Voltage	-	$V_{IHI}$	2	-	-	V
Delay from TX inhibit, (0→1) to inhibited output	Note 1	$t_{DXOFF}$	-	400	500	nS
Delay from TX inhibit, (1→0) to active output	Note 1	$t_{DXON}$	-	400	500	nS
Differential Output Noise, inhibit mode	-	$V_{NOI}$	-	0.8	10	mVp-p
Differential Output Impedance (inhibited)	Note 2	$Z_{OI}$	2K	-	-	Ω

### OUTPUT CHARACTERISTICS

Differential output level, Figure 5, Point A-A"	$R_L = 35 \Omega$	$V_O$	7	7.5	9	Vp-p
Rise and fall times (10% to 90% of p-p output)	ARX4404	$t_R$ & $t_F$	200	250	300	nS
	ARX4407		100	180	300	
Output offset at point A-A' on Figure 3, 2.5 μS after midpoint crossing of the parity bit of the last word of a 660 μS message	$R_L = 35 \Omega$	$V_{OS}$	-	-	±90	mV peak
Delay from 50% point of TX DATA or TX DATA input to zero crossing of differential signal. (Note 1)	ARX4404	tDTX	-	330	450	nS
	ARX4407		-	-	360	nS

## ELECTRICAL CHARACTERISTICS – RECEIVER SECTION

Parameter	Condition	Symbol	Min	Typ	Max	Unit
Differential Input Impedance	f = 1MHz	Z <sub>IN</sub>	10K	-	-	Ω
Differential Input Voltage Range	-	V <sub>IDR</sub>	-	-	40	V <sub>p-p</sub>
Input Common Mode Voltage Range	Note 1	V <sub>ICR</sub>	10	-	-	V <sub>p-p</sub>
Common Mode Rejection Ratio	Note 1	CMRR	40	-	-	dB

### STROBE CHARACTERISTICS (LOGIC "0" INHIBITS OUTPUT)

"0" Input Current	V <sub>S</sub> = 0.4V	I <sub>IL</sub>	-	-0.2	-0.4	mA
"1" Input Current	V <sub>S</sub> = 2.7V	I <sub>IH</sub>	-	1	+40	μA
"0" Input Voltage	-	V <sub>IL</sub>	-	-	0.7	V
"1" Input Voltage	-	V <sub>IH</sub>	2.0	-	-	V
Strobe Delay (Turn-on or Turn-off)	Note 1	t <sub>SD</sub>	-	-	150	nS

### THRESHOLD CHARACTERISTICS (SINEWAVE INPUT)

Internal Threshold Voltage (referred to the bus) pins 6 and 11 grounded	100KHz - 1MHz	V <sub>TH</sub>	0.60	0.8	1.05	V p-p
--	---------------	-----------------	------	-----	------	-------

### OUTPUT CHARACTERISTICS, RX DATA AND RX DATA

"1" State	I <sub>OH</sub> = -0.4 mA	V <sub>OH</sub>	2.5	3.6	-	V
"0" State	I <sub>OL</sub> = 4 mA	V <sub>OL</sub>	-	0.35	0.5	V
Delay (average), from differential input zero crossings to RX DATA and RX DATA output 50% points	Note 1	t <sub>DRX</sub>	-	300	450	nS

## POWER DATA

### POWER SUPPLY CURRENTS (POWER SUPPLIES SET AT +15V, -15V, +5V)

Transmitter Standby		I <sub>CC</sub>		30	60	mA
		I <sub>EE</sub>		50	75	
		I <sub>L</sub>		25	35	
25% duty cycle		I <sub>CC</sub>		50	85	
		I <sub>EE</sub>		70	105	
		I <sub>L</sub>		25	35	
50% duty cycle		I <sub>CC</sub>		75	110	
		I <sub>EE</sub>		45	130	
		I <sub>L</sub>		25	35	
100% duty cycle		I <sub>CC</sub>		120	160	
		I <sub>EE</sub>		140	180	
		I <sub>L</sub>		25	35	

### RECOMMENDED POWER SUPPLY VOLTAGE RANGE

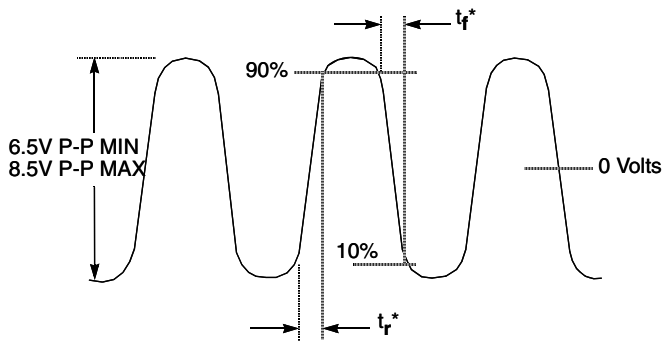
+V	+11.4 Volts to +15.75 Volts
-V	-11.4 Volts to -15.75 Volts
Logic	+4.5 Volts to +5.5 Volts

Notes: 1. Characteristics guaranteed by design, not production tested.

2. Power on or off, measured from 75KHz to 1MHz at point A-A' and transformer self impedance of 3KΩ minimum at 1MHz.

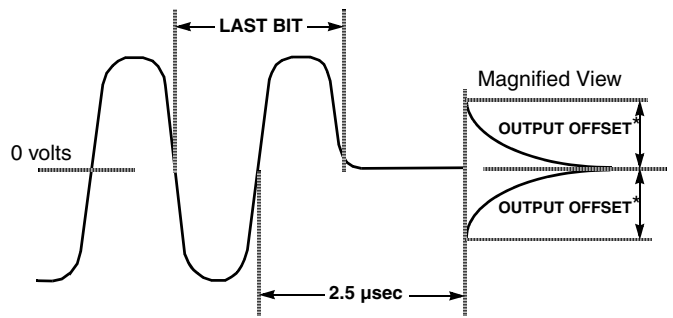
3. Specifications apply over the temperature range of -55°C to +125°C (Case Temperature) unless otherwise noted.

4. All typical values are measured at +25°C.



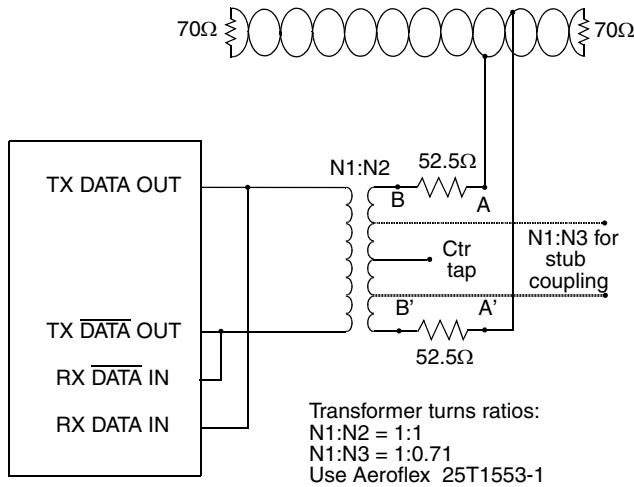
\* Rise and fall times measured at point A-A' in Figure 5

**FIGURE 3 – TRANSMITTER (TX) OUTPUT WAVEFORM**

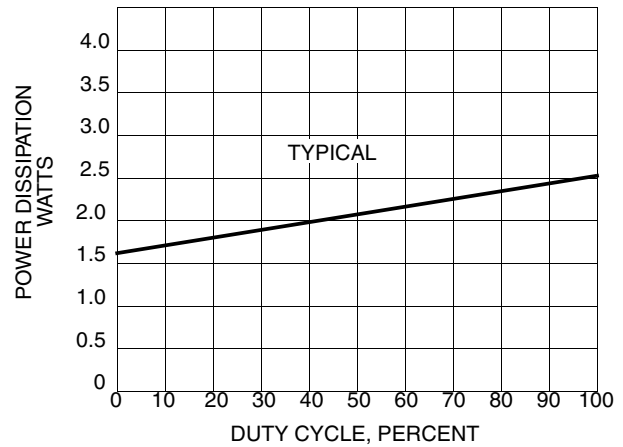


\*Offset measured at point A-A' in Figure 5

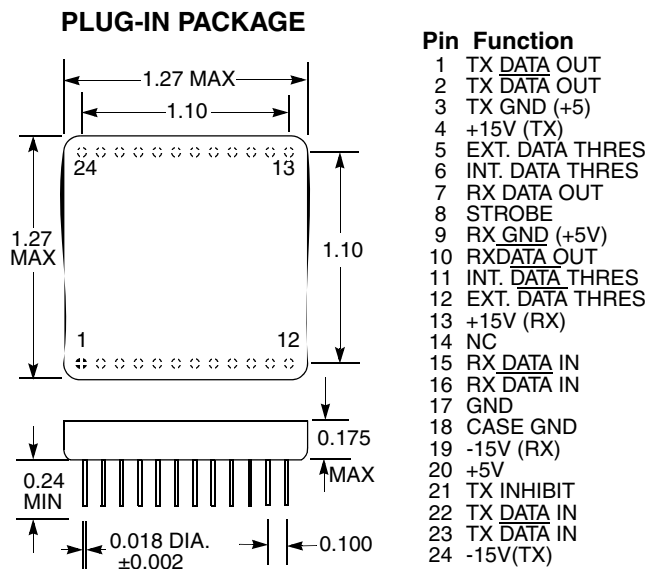
**FIGURE 4 – TRANSMITTER (TX) OUTPUT OFFSET**



**FIGURE 5 – TYPICAL TRANSFORMER CONNECTION**

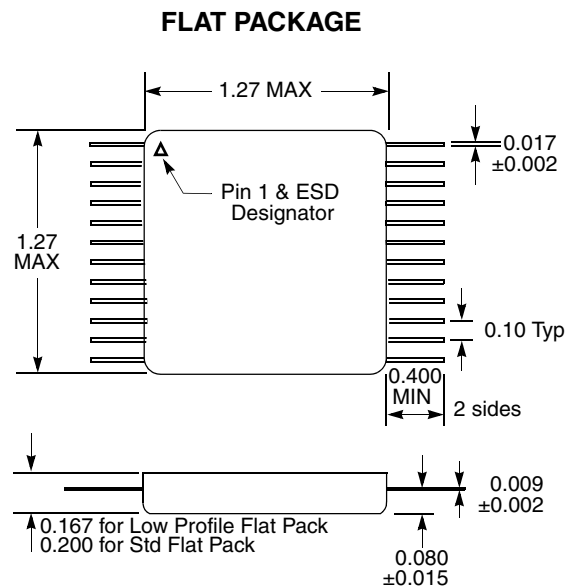


**FIGURE 6 – TYPICAL POWER DISSIPATION vs. DUTY CYCLE**



**Notes**

- Dimensions shown are in inches.
- Pins are equally spaced at 0.100±0.002 tolerance, non-cumulative, each row.



**PACKAGE CONFIGURATION OUTLINE**

## CONFIGURATIONS AND ORDERING INFORMATION \*

Model No.	DESC No.	Receiver Data level	Case	Specs.
ARX4404-001-1	5962-9174909HXC	Normally High	Plug In	1553 & Macair
ARX4404-001-2	5962-9174909HXA		Flat Pack	
ARX4404-201-1	5962-9174909HYC			
ARX4404-201-2	5962-9174909HYA			
ARX4407-001-1	5962-9174908HXC		Plug In	1553
ARX4407-001-2	5962-9174908HXA		Flat Pack	
ARX4407-201-1	5962-9174908HYC			
ARX4407-201-2	5962-9174908HYA			
ARX4440	To Be Assigned	Normally Low	Plug In	1553 & Macair
ARX4440-FP	To Be Assigned		Flat Pack	
ARX4467	To Be Assigned		Plug In	1553
ARX4467-FP	To Be Assigned		Flat Pack	

\* Not for new designs. See ACT4404N Series.

### Special Note

If using the	<b>ARX4404</b>	To replace the	<b>ARX3404</b>
"	<b>ARX4440</b>	"	<b>ARX3464</b>
"	<b>ARX4407</b>	"	<b>ARX3407</b>
"	<b>ARX4467</b>	"	<b>ARX3467</b>

Please note that Pins 6 and 11 must be *GROUND*ED in order for the receiver to operate. These Pins were *No Connect* in the 3400 Series, because the External Variable Threshold was not an option.

**PLAINVIEW, NEW YORK**  
Toll Free: 800-THE-1553  
Fax: 516-694-6715

**INTERNATIONAL**  
Tel: 805-778-9229  
Fax: 805-778-1980

**NORTHEAST**  
Tel: 603-888-3975  
Fax: 603-888-4585

**SE AND MID-ATLANTIC**  
Tel: 321-951-4164  
Fax: 321-951-4254

**WEST COAST**  
Tel: 949-362-2260  
Fax: 949-362-2266

**CENTRAL**  
Tel: 719-594-8017  
Fax: 719-594-8468

[www.aeroflex.com](http://www.aeroflex.com)    [info-ams@aeroflex.com](mailto:info-ams@aeroflex.com)



Aeroflex Microelectronic Solutions reserves the right to change at any time without notice the specifications, design, function, or form of its products described herein. All parameters must be validated for each customer's application by engineering. No liability is assumed as a result of use of this product. No patent licenses are implied.



Our passion for performance is defined by three attributes represented by these three icons: solution-minded, performance-driven and customer-focused