

UTMC APPLICATION NOTE

USING THE BCRTMP WITH MULTIPLE PROTOCOLS

INTRODUCTION

The UTMC UT1553 BCRTMP is a single CMOS chip solution to a multitude of 1553 protocols. This device will implement the Remote Terminal (RT) or Bus Controller (BC) functions for 1553 protocols such as McDonnell Douglas A3818, 5232, 5690, Grumman SPG-151, MIL-STD-1553A, and MIL-STD-1553B. The user need only select the right combination of mode select options via input pins or programmable registers.

This application note discusses and compares these various 1553 protocols. These specifications can vary in several areas, including status word response time, 1553 status word bit definitions, mode codes, and error handling. By understanding these variables, it is simple to configure the BCRTMP to handle any of these protocol. The designer can implement various features to match system-specific requirements.

Several manufacturers have created their own proprietary 1553 specifications. Some of these specifications are based on the MIL-STD-1553A specification, while others are based on MIL-STD-1553B. As a result of the variety of specifications, particularly those based on 1553A, a number

of incompatible 1553 implementations exist. The BCRTMP can be easily configured to handle any of these protocols using programmable mode select pins or register bits.

THE BASIC DIFFERENCES AMONG THE 1553 PROTOCOLS

The basic differences among the 1553 protocols fall into the following categories: status word definition, mode codes, use of broadcast, message error handling, and RT response time.

Status Word Definition

MIL-STD-1553B is quite formal in defining status bits, while the other specifications define or leave bits open to varying degrees for procurement-specific options. All of the 1553 protocols considered in this paper define the Terminal Address, ME (Message Error), and TF (Terminal Flag) status word bits in the same way. The remaining bits are defined in a variety of ways, not only dependent upon the 1553 protocol, but also on the individual procurement specification. Figure 1 illustrates status words for each protocol considered in this paper.

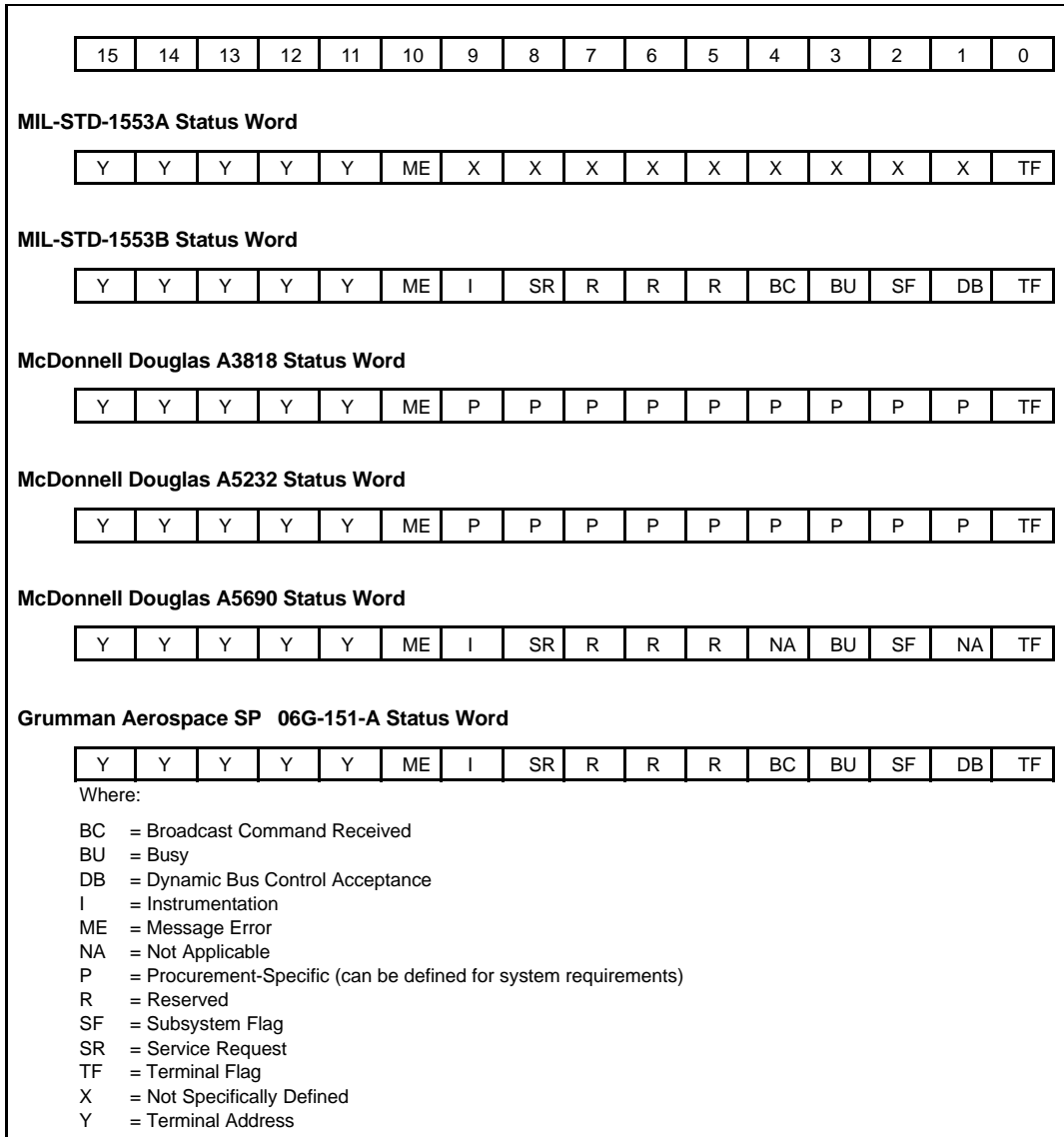

Figure 1. The Various 1553 Status Word Definitions

The BCRTMP contains a user-programmable Status Word Register (Register 15). The user can program any value desired into the status word bit field to conform to selected protocol requirements. Configuring Operational Mode 4, accessed via the input pin (MD4) or the corresponding register bit in the Operational Mode Register (Register 14, bit 4), selects the method of mode code generation.

Mode Codes

Differences in mode code definitions among the 1553 protocols center around the number of defined mode codes and whether mode codes with data are defined. MIL-STD-1553B's definition is quite formal, but the other specifications define to varying degrees the possible mode codes, and may not use mode codes with data. Table 1 illustrates the mode code possibilities for all 1553 protocols considered in this paper.

Table 1. Mode Code Assignments

MIL-STD-1553A Assigned Mode Codes

Trans-Rev Bit	Mode Code	Function	Assoc Data Word	Broadcast Command Allowed
1	00000	Dynamic bus control	No	No
1 or 0	00001	Undefined	No	No
.
1 or 0	11111	Undefined	No	No

MIL-STD-1553B Assigned Mode Codes

Trans-Rev Bit	Mode Code	Function	Assoc Data Word	Broadcast Command Allowed
1	00000	Dynamic bus control	No	No
1	00001	Synchronize	No	Yes
1	00010	Transmit status word	No	No
1	00011	Initiate self-test	No	Yes
1	00100	Transmitter shutdown	No	Yes
1	00101	Override transmitter shutdown	No	Yes
1	00110	Inhibit terminal flag bit	No	Yes
1	00111	Override inhibit terminal flag	No	Yes
1	01000	Reset remote terminal	No	Yes
1	01001	Reserved	No	TBD
.
1	01111	Reserved	No	TBD
1	10000	Transmit vector word	Yes	No
0	10001	Synchronize	Yes	Yes
1	10010	Transmit Last Command	Yes	No
1	10011	Transmit bit word	Yes	No
0	10100	Selected transmitter shutdown	Yes	Yes
0	10101	Override selected transmitter shutdown	Yes	Yes
1 or 0	10110	Reserved	Yes	TBD
.
1 or 0	11111	Reserved	Yes	TBD

McDonnell Douglas A3818 Assigned Mode Codes

Trans-Rev Bit	Mode Code	Function	Assoc Data Word	Broadcast Command Allowed
1	00000	Dynamic bus control	No	No
1 or 0	00001	Procurement-Definable	No	No
.
1 or 0	11111	Procurement-Definable	No	No

McDonnell Douglas A5232 Assigned Mode Codes

Trans-Rev Bit	Mode Code	Function	Assoc Data Word	Broadcast Command Allowed
1	00000	Dynamic bus control	No	No
1 or 0	00001	Procurement-Definable	No	No
.
1 or 0	11111	Procurement-Definable	No	No

McDonnell Douglas A5690 Assigned Mode Codes

Trans-Rev Bit	Mode Code	Function	Assoc Data Word	Broadcast Command Allowed
1	00000	N/A	No	No
1	00001	Synchronize	No	No
1	00010	Transmit status word	No	No
1	00011	Initiate self-test	No	No
1	00100	Transmitter shutdown	No	No
1	00101	Override transmitter shutdown	No	No
1	00110	N/A	No	No
1	00111	N/A	No	No
1	01000	Reset remote terminal	No	No
1	01001	Reserved	No	No
.
1	01111	Reserved	No	No
1	10000	Transmit vector word	Yes	No
0	10001	Synchronize	Yes	No
1	10010	Transmit Last Command	Yes	No
1	10011	Transmit bit word	Yes	No
0	10100	N/A	Yes	No
0	10101	N/A	Yes	No
1 or 0	10110	Reserved	Yes	No
.
1 or 0	11111	Reserved	Yes	No

Grumman SP-G-151A Assigned Mode Codes

Trans-Rev Bit	Mode Code	Function	Assoc Data Word	Broadcast Command Allowed
1	00000	Dynamic bus control	No	No
1	00001	Synchronize	No	Yes
1	00010	Transmit status word	No	No
1	00011	Initiate self-test	No	Yes
1	00100	Transmitter shutdown	No	Yes
1	00101	Override transmitter shutdown	No	Yes
1	00110	Inhibit terminal flag bit	No	Yes
1	00111	Override inhibit terminal flag	No	Yes
1	01000	Reset remote terminal	No	Yes
1	01001	Reserved	No	TBD
.
1	01111	Reserved	No	TBD
1	10000	Transmit vector word	Yes	No
0	10001	Synchronize	Yes	Yes
1	10010	Transmit Last Command	Yes	No
1	10011	Transmit bit word	Yes	No
0	10100	Selected transmitter shutdown	Yes	Yes
0	10101	Override selected transmitter shutdown	Yes	Yes
1 or 0	10110	Reserved	Yes	TBD
.
1 or 0	11111	Reserved	Yes	TBD

The BCRTMP allows flexible mode code implementation. This flexibility includes the selection of only mode codes with data or only mode codes without data. The user can also select automatic execution of modes codes, as defined in MIL-STD-1553B, or configure the BCRTMP to respond with status and allow the host to execute a mode code. Finally, the user can configure the BCRTMP to determine the reception of a mode code command with either all ones AND all zeros in the subaddress field, or all zeros only. This flexibility allows the device to be configured for mode code operation for any of the 1553 protocols discussed. The source selection for the status word is accomplished via the Operational Mode 3, accessed either through the input pin (MD3) or bit 3 of the Operational Mode Register (Register 14). The selection of mode codes with data versus without data is accomplished with Operational Mode 6. This is accessed via the input pin (MD6) or the corresponding register bit in the Operational Mode Register (Register 14, bit 6).

Use Of Broadcast

The 1553 protocol differences include the broadcast option. For protocols that support the broadcast option, the RT address 11111 is reserved to indicate a broadcast command. When a broadcast command is transmitted, all RTs must receive the message. No RT is to respond with a status word.

Protocols that do support the broadcast option treat RT address 11111 as a normal RT address.

The BCRTMP allows the use or disabling of broadcast commands. When broadcast is disabled, then RT address 11111 is treated as a normal RT address via the Operational Mode 1, accessed either through the input pin (MD1) or bit 1 of the Operational Mode Register (Register 14).

Message Error Handling

Some 1553 protocols (MIL-STD-1553B, McDonnell Douglas A5690, and Grumman SP-G-151A) consider any message error reason to discard the entire message and suppress the status word, while others (MIL-STD-1553A, and McDonnell Douglas A3818 and A5232) react according to message error severity. In the latter three protocols, if a Manchester error or parity error occurs in a data word, the defective data word is discarded but the remainder of the message can be used. The RT then responds with the status word with the Message Error bit set.

Status Word Suppression For Erroneous Transactions (MIL-STD-1553B, McDonnell Douglas A5690, Grumman SP-G-151A)

The criteria for suppressing a status word for message error condition for an RT that conforms to these protocols is defined as follows:

- Any data word that contains a parity error.
- Any data word that contains a Manchester error.
- Any data word that contains an invalid sync.
- The remote terminal received an incorrect number of data words.

If any of the above conditions occur, the RT suppresses status and sets the Message Error bit.

Note: If the command word is in error, or is going to another RT address, then the RT does not consider the message.

Status Word Suppression For Erroneous Transactions(MIL-STD-1553A, McDonnell Douglas A3818 and A5232)

The criteria for suppressing a status word for an RT message error condition that conforms to these protocols is defined as follows:

- Any data word that contains an invalid sync.
- The remote terminal received an incorrect number of data words.

If any of the above conditions occur, the RT suppresses status and sets the Message Error bit.

Note: If the command word is in error or is going to another RT address, the RT does not consider the message.

If the above-listed conditions did not occur for a message, but one of the following conditions occurs, the RT sends status with the Message Error bit set.

- Any data word that contains a parity error.
- Any data word that contains a Manchester error.

The user can configure the BCRTMP to handle errors in accordance with either of the methods discussed above via the Operational Mode 5, accessed either through the input pin (MD5) or bit 5 of the Operational Mode Register (Register 14). Note: The BCRTMP validates each data word on sync and two bits.

RT Response Time

The RT response time differs among the 1553 protocols. RT response time measurement is from the parity bit's zero crossing of the receive command's last data word, or the command word's zero crossing for a transmit command to the status word sync's zero crossing.

The maximum response time allowed for an RT in a MIL-STD-1553A or McDonnell Douglas A3818 or A5232 system is 7.0ms; for an RT in a MIL-STD-1553B, McDonnell Douglas A5690, or Grumman SP-G-151G system it is 12.0ms.

The BCRTMP can be configured for a response time in accordance with the above requirements via Operational Mode 2. It is accessed via the input pin (MD2), or the corresponding register bit in the Operational Mode Register (Register 14, bit 2).

**Protocol Comparisons
1553 Protocol Features**

1553 Protocol	Message Error Method	Broadcast Allowed	Status Bits	Maximum Response Time
1553A	A3818	No	Definable	7µs
1553B	1553B	Yes	Defined	12µs
MDC A3818	A3818	No	Definable	7µs
MDC A5232	A3818	No	Definable	7µs
MDC A5690	1553B	Yes	Definable	12µs
Grumman SPG151A	1553B	No	Definable	12µs

Where:

553A Response Time = 4.0 to 12.0ms, as measured from parity zero cross to sync zero cross.

1553B Response Time = 4.0 to 12.0ms, as measured from parity zero cross to sync zero cross.

BCRTMP Response Time is 5.5ms (using Legalization bus).

BCRTMP Response Time is 10ms (using DMA).

A3818 Message Error Handling Method: The status word is transmitted with Message Error bit set if a data word parity or Manchester error occurs.

1553B Message Error Handling Method: The status word is transmitted with Message Error bit set if a data word parity or Manchester error occurs.

DESIGN CONSIDERATIONS FOR IMPLEMENTING 1553 PROTOCOLS

Substantial differences among 1553 protocols create challenging obstacles for creating a BCRT that conforms to all 1553 protocols. Design considerations fall into the following categories: status word definition, mode codes, use of broadcast, message error handling, and RT response time.

Designing For Status Word Flexibility

The status word must be flexible in order to conform to a variety of 1553 protocols. The BCRTMP can operate in a mode where the status word is defined in strict correspondence with the MIL-STD-1553B specification or it can operate in a more flexible mode. In the flexible status word mode, the user can program the individual status word bits via read/write registers.

Designing For All Mode Code Possibilities

Two of the BCRTMP's mode options address the need for mode code flexibility. The designer can place the BCRTMP in an operational mode so the device performs in strict correspondence with the mode code definitions for MIL-STD-1553B. Illegalization of any unsupported mode code can occur in one of two ways: (1) The designer can illegalize the mode code via the Legalization bus (figure 2), or (2) the device can perform illegalization via DMA Descriptor Block fetches (figure 3).

The BCRTMP can also accommodate a flexible mode code definition by employing two operational mode options. One option allows the device to employ mode codes with or without data. If it employs mode codes with data, it allows only single data word transfers using the data word rules established in MIL-STD-1553B. Alternatively, an operational mode completely disallows mode codes with data.

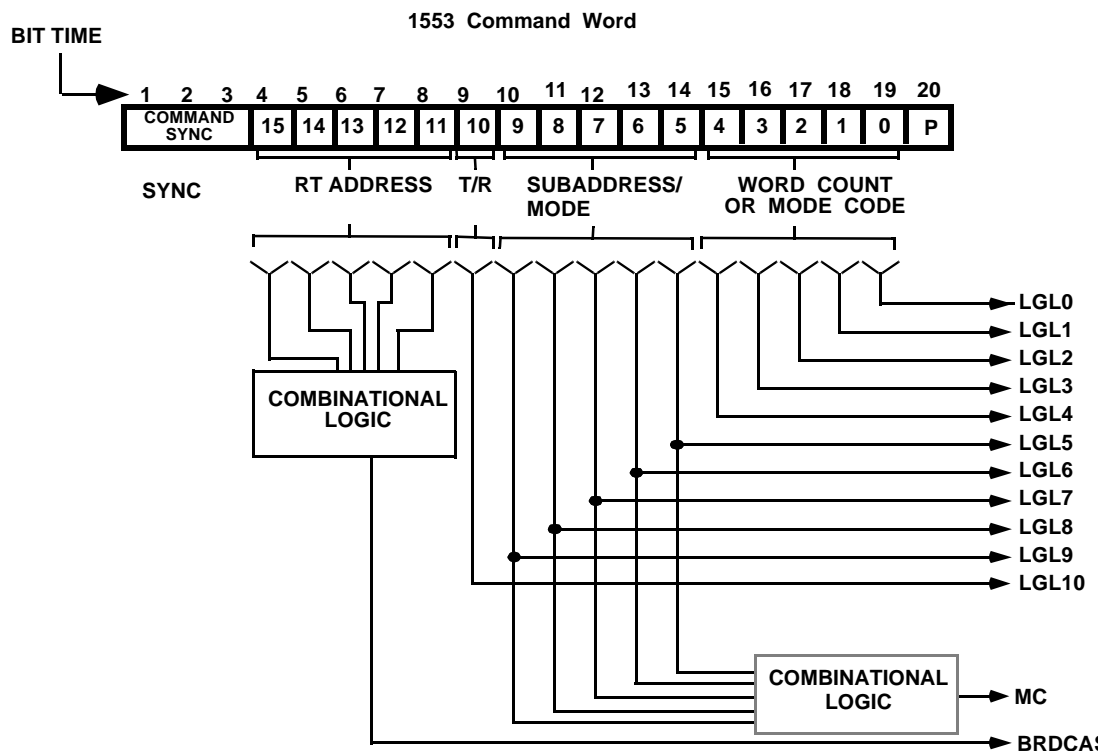

Figure 2. BCRTMP Legalization Bus

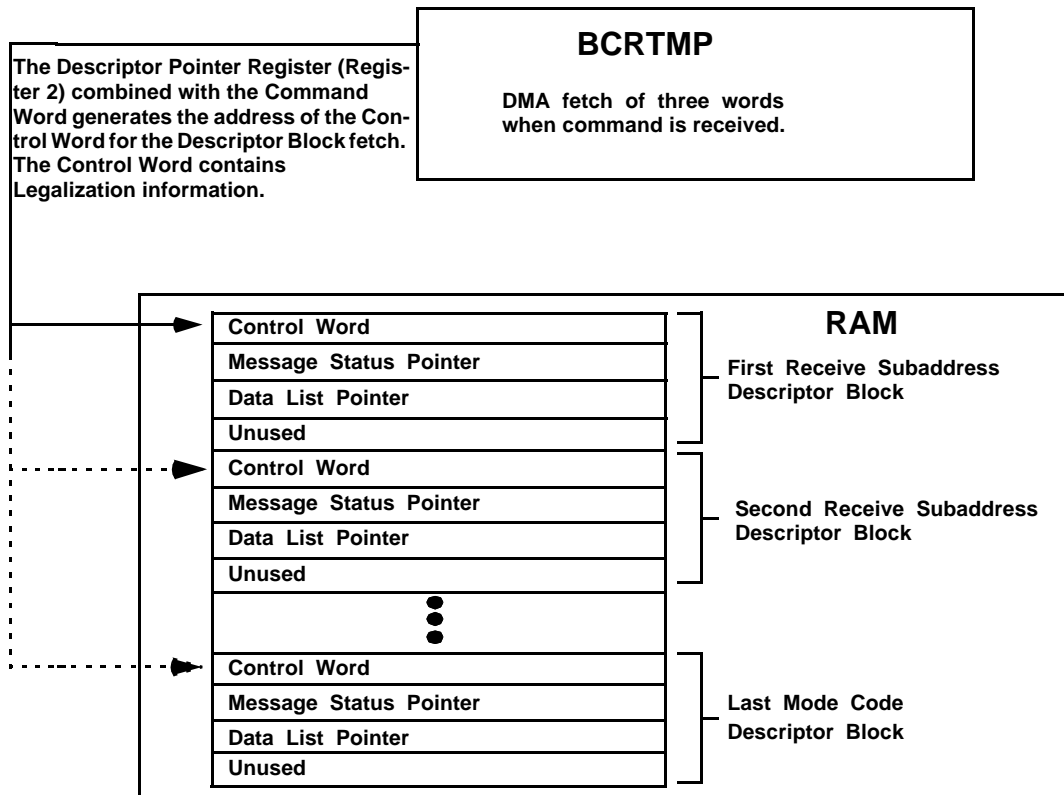

Figure 3. BCRTMP Descriptor Block Legalization

Designing For Broadcast

The broadcast option may or may not be included in a particular 1553 protocol. The BCRTMP has a programmable mode option that allows the user to determine whether to allow broadcast commands in a system. If broadcast commands are allowed, then any command to RT address 11111 is considered a broadcast command. If broadcast commands are not allowed, then a command to RT address 11111 is considered a normal command.

Designing For Both Message Error Handling Techniques

The two message error handling techniques in 1553 protocols require a flexible design. The message error handling technique described above, the A3818 method, is a particularly difficult design to use. The remote terminal must be able to distinguish the severity of message errors. A less severe error, either a Manchester error or a parity error in a data word, requires special attention. The RT must mark the individual defective data word and respond with the Message Error bit set in the status word.

The BCRTMP accomplishes this challenging task. When a Manchester or parity error occurs in a data word, the BCRTMP asserts the ERRB signal and places the word count for the defective data word in bits 0-4 of the Legalization bus. In a typical system, the ERRB signal can control a TTL FIFO (first-in/first-out) device, and can strobe the word count into the device. The system can examine the FIFO at the end of the message to determine if the message contains defective data. If the message has defective data, the data can be identified by reading the FIFO (figure 4).

The alternative and much simpler message error handling technique treats all message errors the same way. If a message error occurs in this operational mode, the system discards the entire message. The RT sets the Message Error bit in the status bit, but suppresses transmitting the status word.

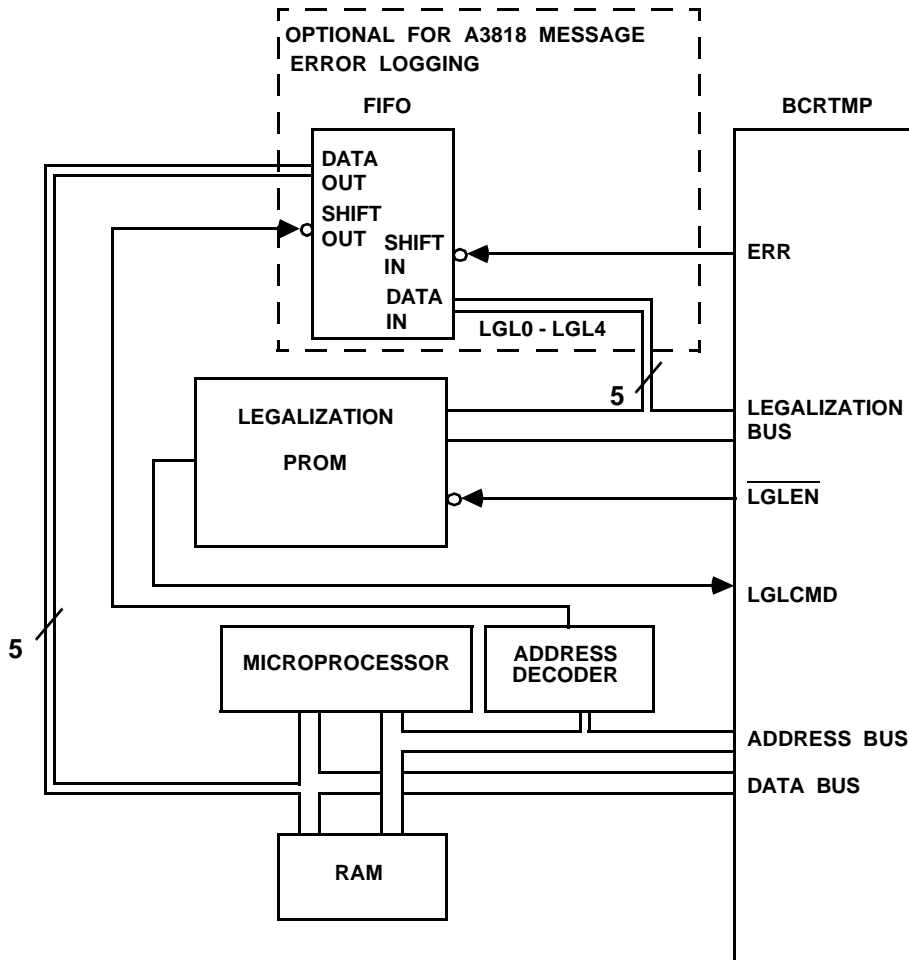

Figure 4. BCRTMP Bus Legalization Example

Designing For Flexible RT Response Time

The two 1553 response times require a flexible design. The minimums are either 7ms or 12ms. The BCRTMP can accommodate either response time by selecting the appropriate mode options. Either response time can be accommodated while using the Legalization bus for command illegalization. The faster response time requires

use of the Legalization bus. The slower response time can be met using the DMA Descriptor Block fetch method.

Figure 5 illustrates the system timing for the Legalization bus and figure 6 shows RT response time for both modes of operation

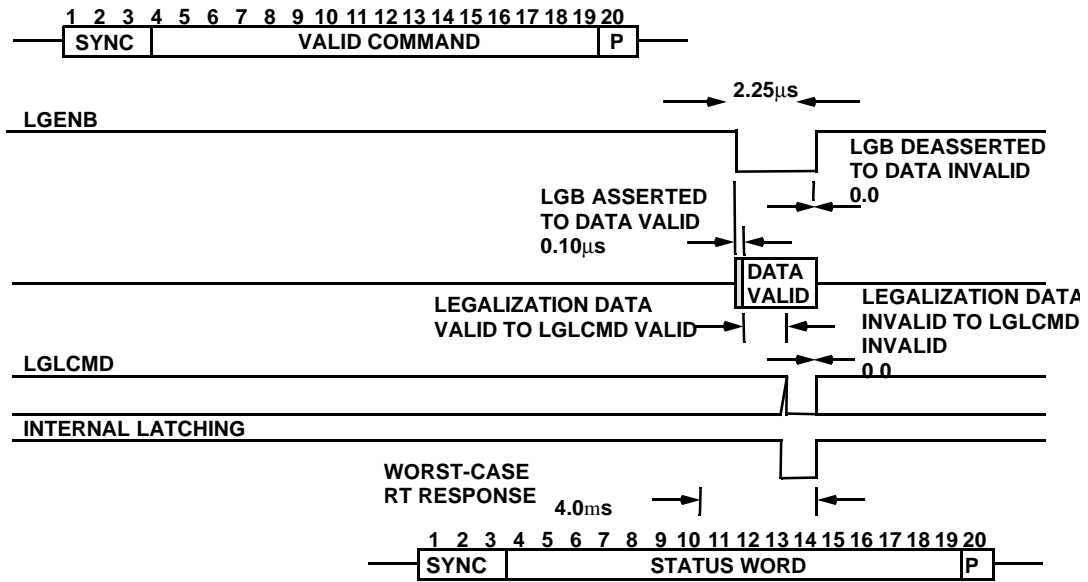

Figure 5. Illegalization Bus Timing

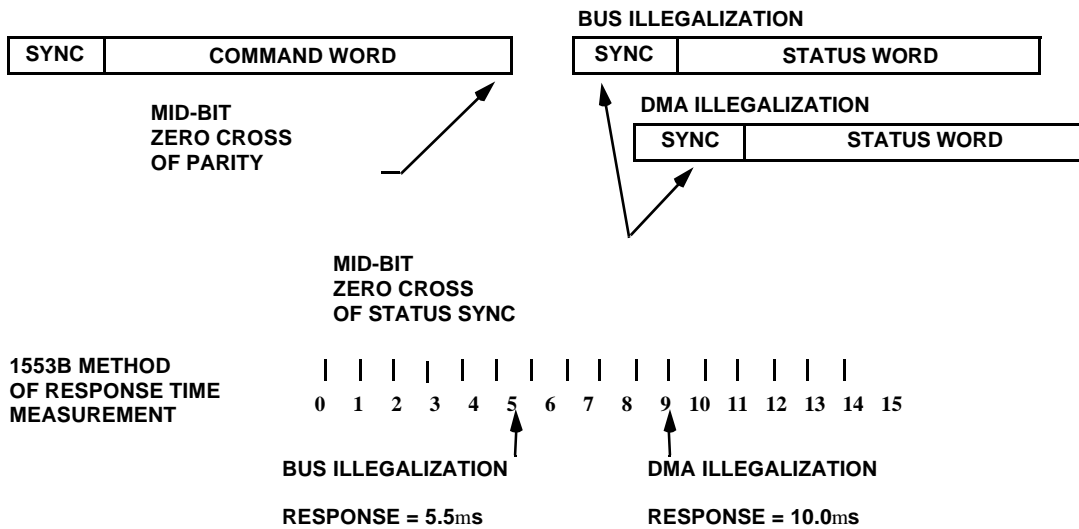

Figure 6. BCRTMP Worst-Case Response Time

PROGRAMMABLE MODE OPTIONS

Six programmable mode options provide flexibility and address the characteristics that vary among the 1553 protocols. The designer can configure the BCRTMP to operate in a wide variety of modes by using the device's mode select pins. Each mode select is accessible via an internal register as well.

Six programmable mode options provide flexibility and address the characteristics that vary among the 1553 protocols. The designer can configure the BCRTMP to operate in a wide variety of modes by using the device's mode select pins. Each mode select is accessible via an internal register as well.

MODE0 Illegalization Select

MODE0 illegalization select chooses either DMA or bus illegalization. A high on this signal selects DMA illegalization, while a low on this signal selects bus illegalization. When the BCRTMP operates as an RT with the 1553A response time, MODE0 bit must be low because it is impossible to meet the 1553A response time and use DMA illegalization.

Bus illegalization is a method by which the 1553 command word, minus the RT address, is routed to the Legalization bus. The BCRTMP uses this information, for example, as a PROM address. The single-bit output from the PROM then feeds to the LEGAL input signal of the BCRTMP. If a command is considered legal, the PROM output is high; if a command is considered illegal, the PROM output is low.

DMA illegalization allows the BCRTMP to access a specific Descriptor Block when it receives a given command. The Descriptor Block contains information the BCRTMP uses to determine if the command is considered legal or illegal.

In both illegalization methods, if the command is illegal, the BCRTMP sends a status word with the Message Error bit set (bit 10); it does not transmit data when it receives an illegal message. When the illegal command is a broadcast command, and broadcast is enabled, the BCRT suppresses the status word.

MODE1 Broadcast Enable

The MODE1 broadcast enable signal determines whether the selected protocol contains broadcast commands. When this signal is high, the selected 1553 protocol contains the broadcast option. When the RT address is 11111 (binary), the command is considered a broadcast command.

When this signal is low, the selected 1553 protocol selected does not contain the broadcast option. When the RT address is 11111 (binary), the command goes to a normal unique RT address.

MODE2 Response Time Select

The MODE2 response time select signal determines the response time for the status word. When this signal is high, the response time is nominally 10ms as measured from the parity bit's zero crossing to the status word sync zero crossing.

When this signal is low, the response time is nominally 5.0ms as measured from the parity bit's zero crossing to the status word sync zero crossing. When the 5.0ms response time is selected, the BCRTMP performs illegalization via the bus.

MODE3 Protocol Selection

MODE3 protocol selection selects between two sets of protocol options. When this signal is high, the device uses the 1553B protocol options. When this signal is low, the device uses the 1553A protocol options. The functions these protocol options affect include mode code execution and status word bit definition.

When in the 1553B mode, all ones or all zeros in the subaddress field determine a mode code command. When in the 1553B mode, the mode codes are rigidly defined according to MIL-STD-1553B.

When in the 1553A mode, all ones in the subaddress field indicate a mode code command.

When in the 1553A mode, the mode codes are more flexible since the MIL-STD-1553A and derivative specifications can treat the mode code definitions flexibly. Likewise, the status word is programmable to accommodate the loose definition in the MIL-STD-1553A specification.

MODE4 Message Error Handling Method

The MODE4 message error handling method select signal selects between two message error handling methods. When this signal is high, the BCRTMP handles message errors as defined in MIL-STD-1553B. When this signal is low, the BCRTMP handles message errors as defined in McDonnell Douglas A3818. The differences in standards deal with Manchester and parity errors when they occur in a data word. With MIL-STD-1553B, when a Manchester or parity error occurs in any data word for a given message, the correct RT response is to suppress the status word and set the Message Error bit.

With A3818, when a Manchester or parity error occurs in a data word, the RT does not use the erroneous data, but the status word must be sent with the Message Error bit set. To provide the means for the RT system to discard only the erroneous data word, the BCRTMP strobes the ERFB signal and places the word count for the erroneous word on the least significant five bits of the Legalization bus. If only Manchester or parity errors occur in data words, the BCRTMP transmits the status word with the Message Error bit set.

MODE5 Mode Code With Data Select

The MODE5 mode code with data select signal selects between two 1553A protocol mode code options. When this signal is internally pulled high, mode codes with data are not allowed. As such, no mode code has an associated data word.

When this signal is pulled low, mode codes with data are allowed; the data rules follow MIL-STD-1553B. mode codes 00000 - 01111 do not have data. mode codes 10000 - 11111 do have an associated data word. The data is sent from the RT if the Transmit/Receive bit is 1. The data is sent to the RT if the Transmit/Receive bit is 0.

In the 1553A mode (i.e., MD3 is low), the BCRTMP handles the data word as a single data word transmit or receive command.

In the 1553B mode (i.e., MD3 is high), mode codes correspond strictly with MIL-STD-1553B.

Summary

The BCRTMP was designed with thorough consideration of all characteristics that might vary among a group of commonly used 1553 protocols. Carefully characterization of all variable criteria led to creation of a set of programmable mode options that address all 1553 protocols.