

# Design Information Fact Sheet

## SpaceWire Family

### What is SpaceWire?

The SpaceWire standard is a self-managing serial protocol that provides a high speed, low power serial interface while offering a flexible simple user interface. The protocol is derived from IEEE 1355-1995. The benefits are straightforward, a simple protocol, a simple user interface (FIFO) with high data rate and lower power using LVDS as the physical layer. Aeroflex Colorado Springs saw the benefits of the SpaceWire Standard used in numerous European programs and announced the development of their SpaceWire Family in 2005 with the UT200SpWPHY Transceiver and have added a Protocol Handler for their RadHard Eclipse FPGA. A SpaceWire 4-port Router is planned for 4Q08.

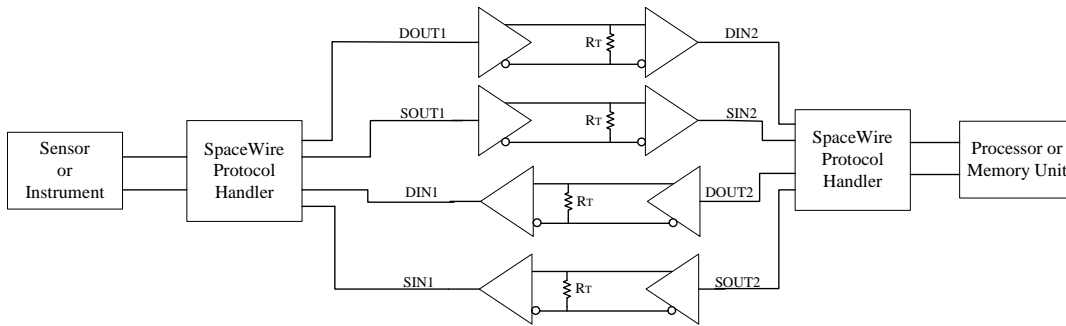

**Point-to-Point Communication**

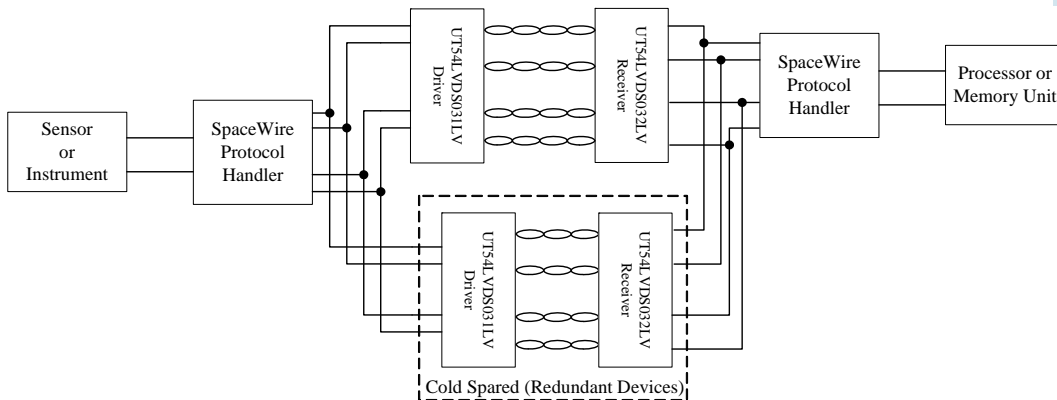

**Redundant Point-to-Point**

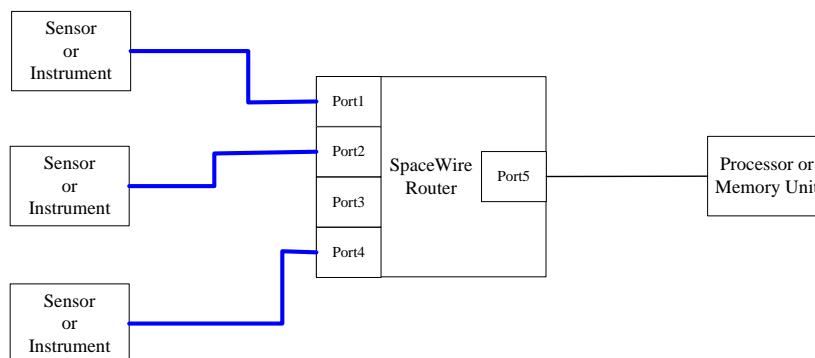

**Router Implementation**

### UT100SpW02 SpaceWire Protocol Handler IP for RadHard Eclipse FPGA

- ❑ Designed for use with the RadHard Eclipse FPGA (view datasheet at [www.aeroflex.com/RadHardFPGA](http://www.aeroflex.com/RadHardFPGA))
- ❑ Data rates from 2 to 100 Mbits/sec
- ❑ Dual ECSS-E-50-12A compliant links
- ❑ 9 bit transmit and receive FIFO user interface

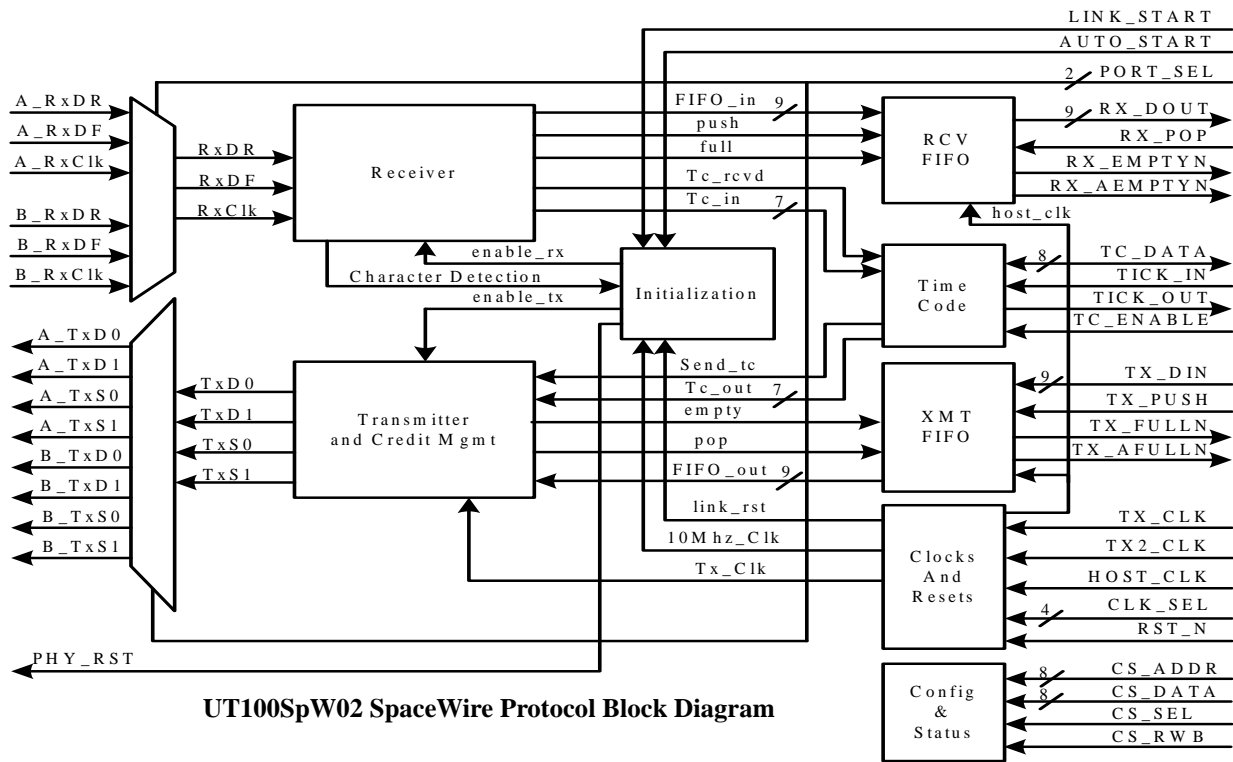

**UT100SpW02 SpaceWire Protocol Block Diagram**

### UT100SpWPHY Transceiver

- ❑ 2-bit Serializer/Deserializer (SerDes) functionality
- ❑ LVDS physical layer
- ❑ Data rates to 200 Mbits/sec
- ❑ Data/Strobe transmit skew <500ps
- ❑ 3.3V power supply
- ❑ Cold spare all LVDS pins

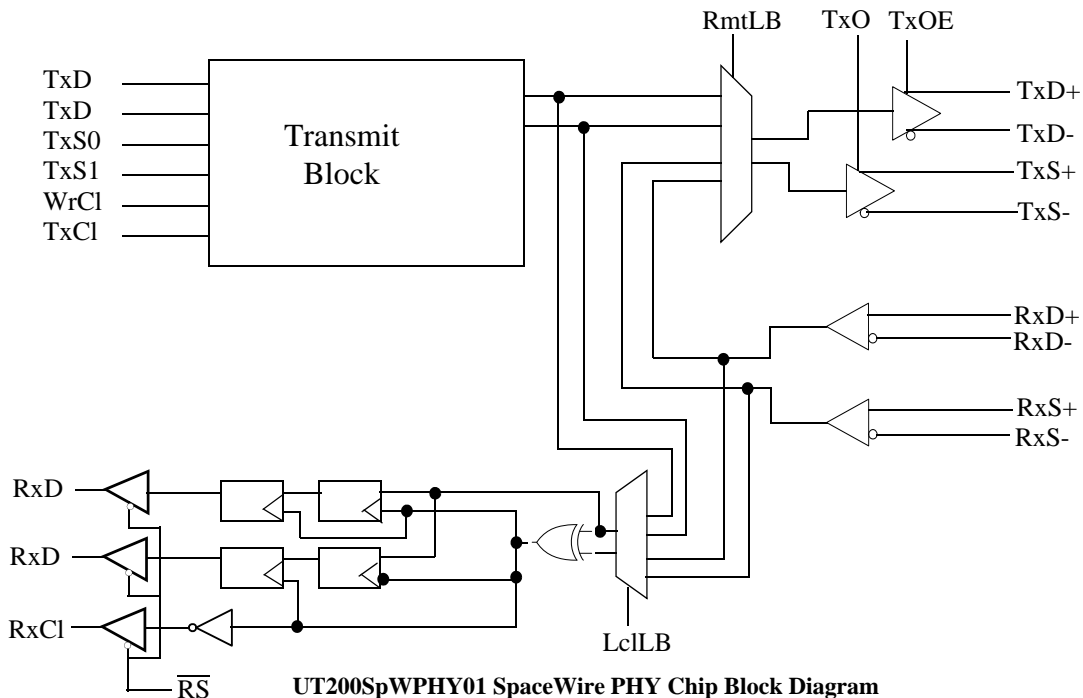

**UT200SpWPHY01 SpaceWire PHY Chip Block Diagram**

## UT200SpW4RTR 4-Port SpaceWire Router

- ❑ 4-port SpaceWire router with a system interface port for a total of 5 ports
- ❑ Data rates up to 200Mbps on all 4 SpaceWire ports
- ❑ 2.5V core power supply, 3.3V I/O power supply
- ❑ Compliant to the SpaceWire Standard, Document Number ECSS-E-50-12A (<http://www.ecss.nl/>)
- ❑ Group adaptive routing for 2 ports when using logical addressing
- ❑ Host (FIFO) clock frequency: 50MHz
  - 9 by 128 receive and transmit FIFOs on each port

**Aeroflex UT200SpW4RTR  
4 Port SpaceWire Router**

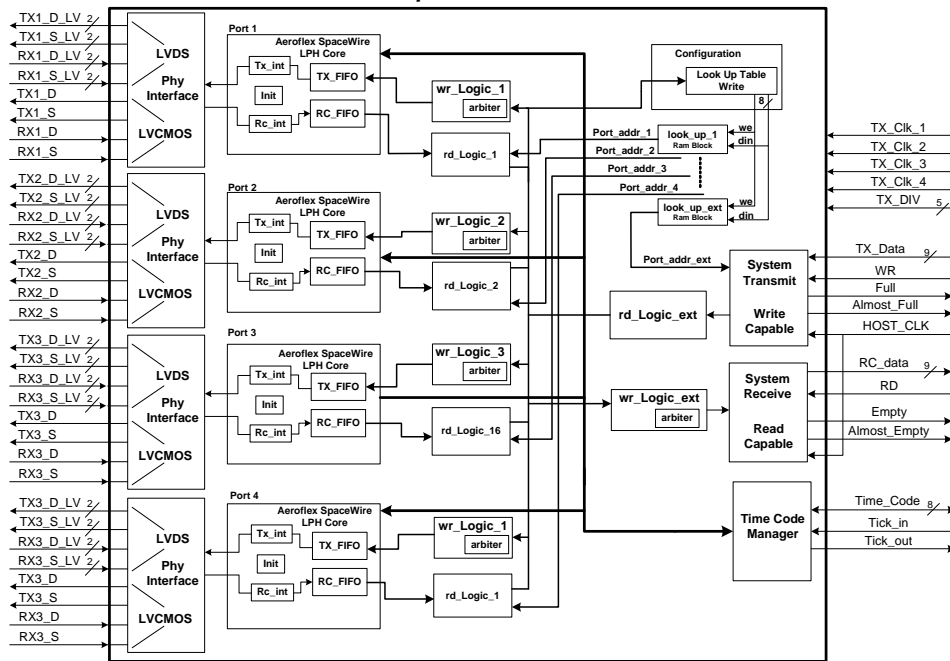

## SpaceWire Design Examples

The distributed or partially connected SpaceWire network is one where the nodes are connected to one or more of the other nodes in the network. A point-to-point link between the nodes allows for some redundancy.

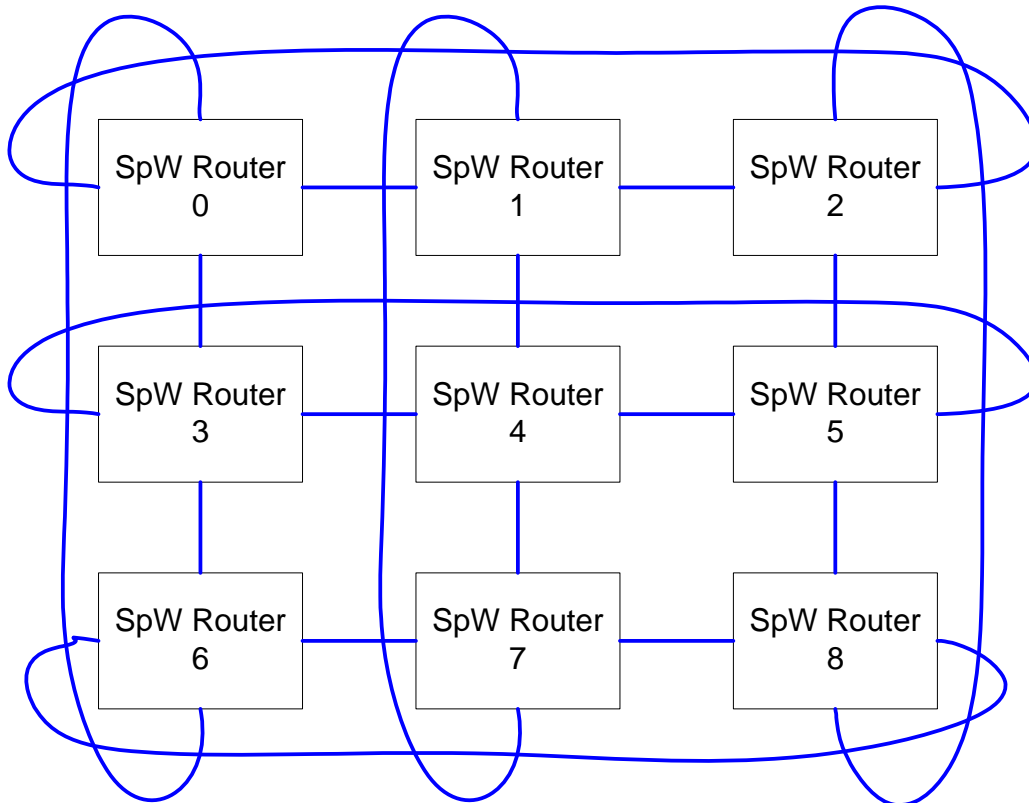
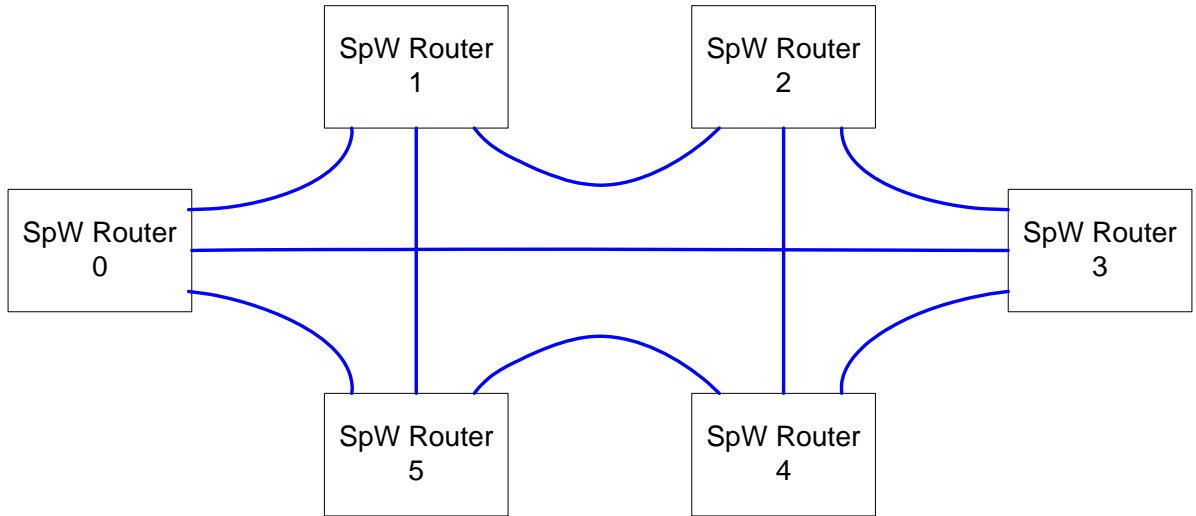

The centralized SpaceWire network has a router at the center of the network that acts as the arbitrator of messages. This topology reduces the chance of network failure by connecting all of the system to a central node. All peripheral SpaceWire nodes must communicate with all other nodes by transmitting to and receiving from the central node (router).

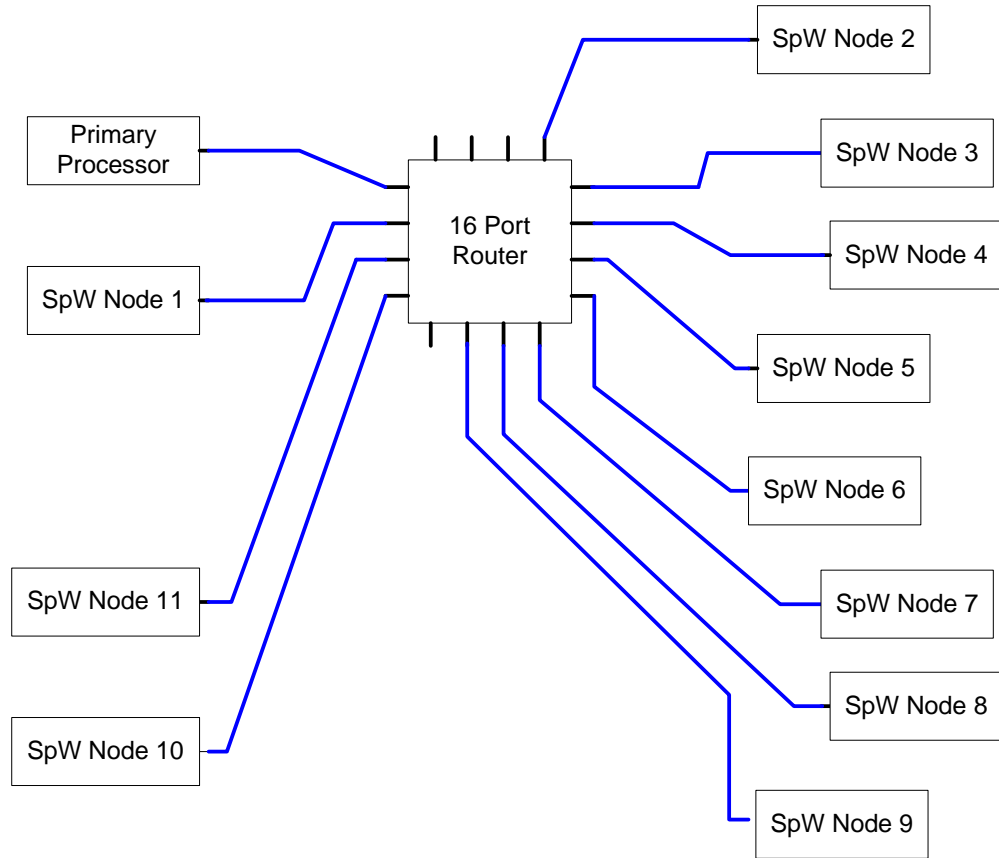

# SpaceWire Node Design Example

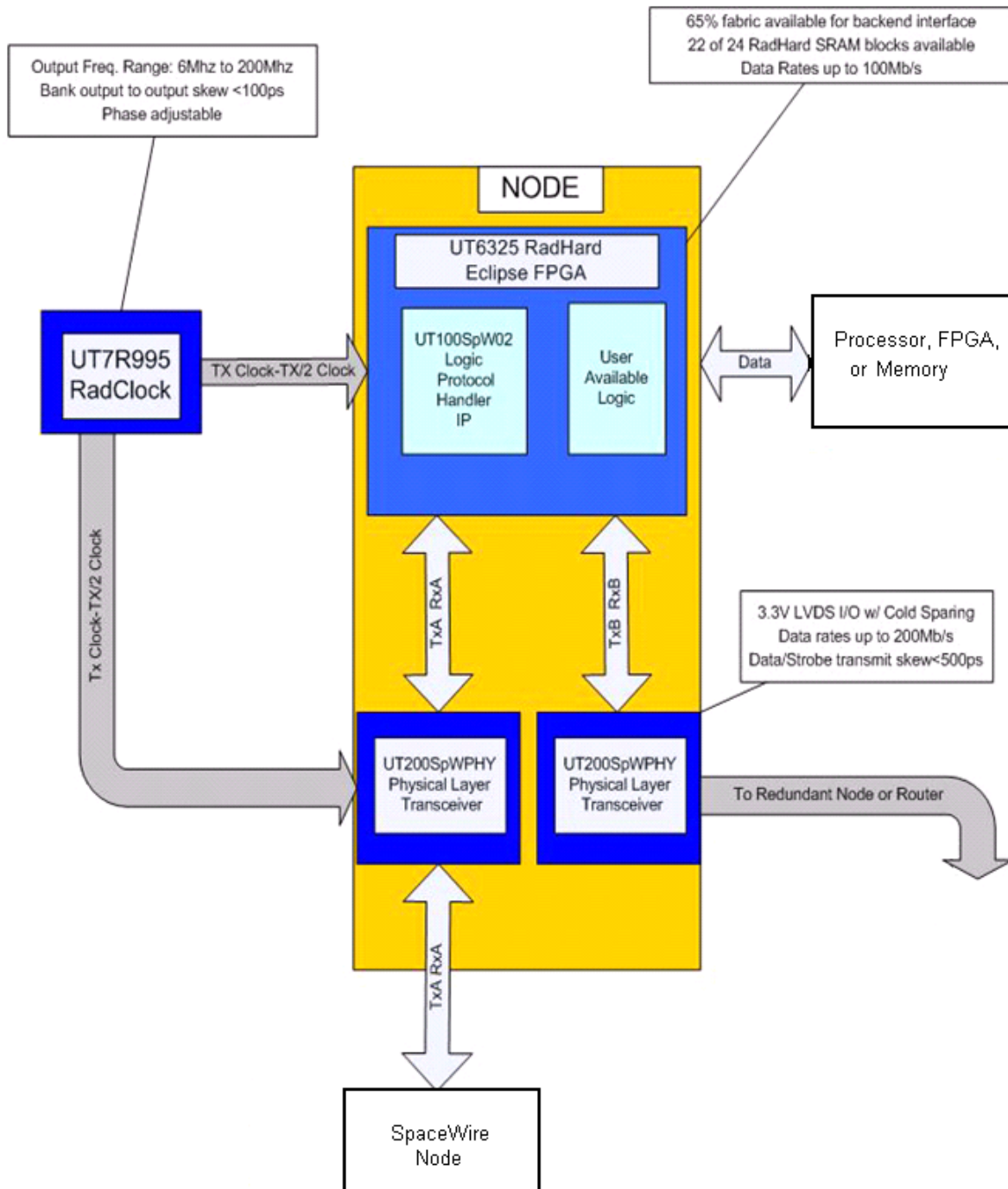

**Internet Resources:**

**Visit [www.aeroflex.com/SpaceWire](http://www.aeroflex.com/SpaceWire) to download:**

- SpaceWire Data Sheets
- IBIS Models

Visit [www.aeroflex.com/RadHard](http://www.aeroflex.com/RadHard) to see the latest Aeroflex Colorado Springs' RadHard products for space applications!



**COLORADO**

Toll Free: 800-645-8862  
Fax: 719-594-8468

**INTERNATIONAL**

Tel: 805-778-9229  
Fax: 805-778-1980

**NORTHEAST**

Tel: 603-888-3975  
Fax: 603-888-4585

**SE AND MID-ATLANTIC**

Tel: 321-951-4164  
Fax: 321-951-4254

**WEST COAST**

Tel: 949-362-2260  
Fax: 949-362-2266

**CENTRAL**

Tel: 719-594-8017  
Fax: 719-594-8468

[www.aeroflex.com](http://www.aeroflex.com)    [info-ams@aeroflex.com](mailto:info-ams@aeroflex.com)

Aeroflex Colorado Springs, Inc., reserves the right to make changes to any products and services herein at any time without notice. Consult Aeroflex or an authorized sales representative to verify that the information in this data sheet is current before using this product. Aeroflex does not assume any responsibility or liability arising out of the application or use of any product or service described herein, except as expressly agreed to in writing by Aeroflex; nor does the purchase, lease, or use of a product or service from Aeroflex convey a license under any patent rights, copyrights, trademark rights, or any other of the intellectual rights of Aeroflex or of third parties.



Our passion for performance is defined by three attributes represented by these three icons: solution-minded, performance-driven and customer-focused