

Design Information Fact Sheet

UT8ER512K32 Monolithic 16M RadHard SRAM



FEATURES

- ❑ 20ns read, 10ns write maximum access times
- ❑ Functionally compatible with traditional 512K x 32 SRAM devices
- ❑ CMOS compatible inputs and output levels, three-state bidirectional data bus
 - 3.3 volt I/O, 1.8 volt core
- ❑ Radiation performance
 - Total-dose: >100Krad(Si)
 - SEL Immune: 100MeV-cm²/mg
 - SEU error rate = 6.01x10⁻¹⁶ errors bit/day assuming geosynchronous orbit, Adam's 90% worst environment, and 156KHz default scrub rate (=99.4% SRAM availability)
 - Neutron Fluence: 3.0E14n/cm²
- ❑ Packaging options:
 - 68-lead ceramic quad flatpack (6.898 grams)
- ❑ Standard Microcircuit Drawing 5962-06261
 - QML compliant part

INTRODUCTION

The UT8ER512K32 is a high-performance CMOS static RAM organized as 524,288 words by 32 bits. Easy memory expansion is provided by active LOW and HIGH chip enables ($\overline{E1}$, E2), an active LOW output enable (\overline{G}), and three-state drivers. This device has a power-down feature that reduces power consumption by more than 90% when deselected.

Writing to the device is accomplished by driving chip enable one ($\overline{E1}$) input LOW, chip enable two (E2) HIGH and write enable (\overline{W}) input LOW. Data on the 32 I/O pins (DQ0 through DQ31) is then written into the location specified on the address pins (A0 through A18). Reading from the device is accomplished by taking chip enable one ($\overline{E1}$) and output enable (\overline{G}) LOW while forcing write enable (\overline{W}) and chip enable two (E2) HIGH. Under these conditions, the contents of the memory location specified by the address pins will appear on the I/O pins.

The 32 input/output pins (DQ0 through DQ31) are placed in a high impedance state when the device is deselected ($\overline{E1}$ HIGH or E2 LOW), the outputs are disabled (\overline{G} HIGH), or during a write operation ($\overline{E1}$ LOW, E2 HIGH and \overline{W} LOW).

UT8ER512K32 Master or Slave Options

To reduce bit error rates caused by single event phenomenon in space, the UT8ER512K32 employs an embedded EDAC (error detection and correction) with code engine with auto scrubbing. When a double bit error occurs in a word, the UT8ER512K32 asserts an \overline{MBE} output to the host.

The UT8ER512K32 is offered in two options: Master or Slave. The UT8ER512K32M (Master) is a full function device capable of autonomous EDAC scrubbing which can also be used to demand scrub cycles on the UT8ER512K32S (Slave) by connecting the SCRUB pins on each device. The UT8ER512K32S (Slave) only performs EDAC scrub cycles when its SCRUB pin is driven by an external controller. The scrub-on-demand feature allows multiple UT8ER512K32S (Slave) devices to be controlled by one UT8ER512K32M (Master) device. The SCRUB function is a no connect (NC) on the UT8ER512K32S (Slave), and is used by the UT8ER512K32M (Master) to generate wait states in the memory controller. The BUSY function is an output on the Master device while on the Slave device it is an input.

RadHard 16M Monolithic SRAM Design Examples

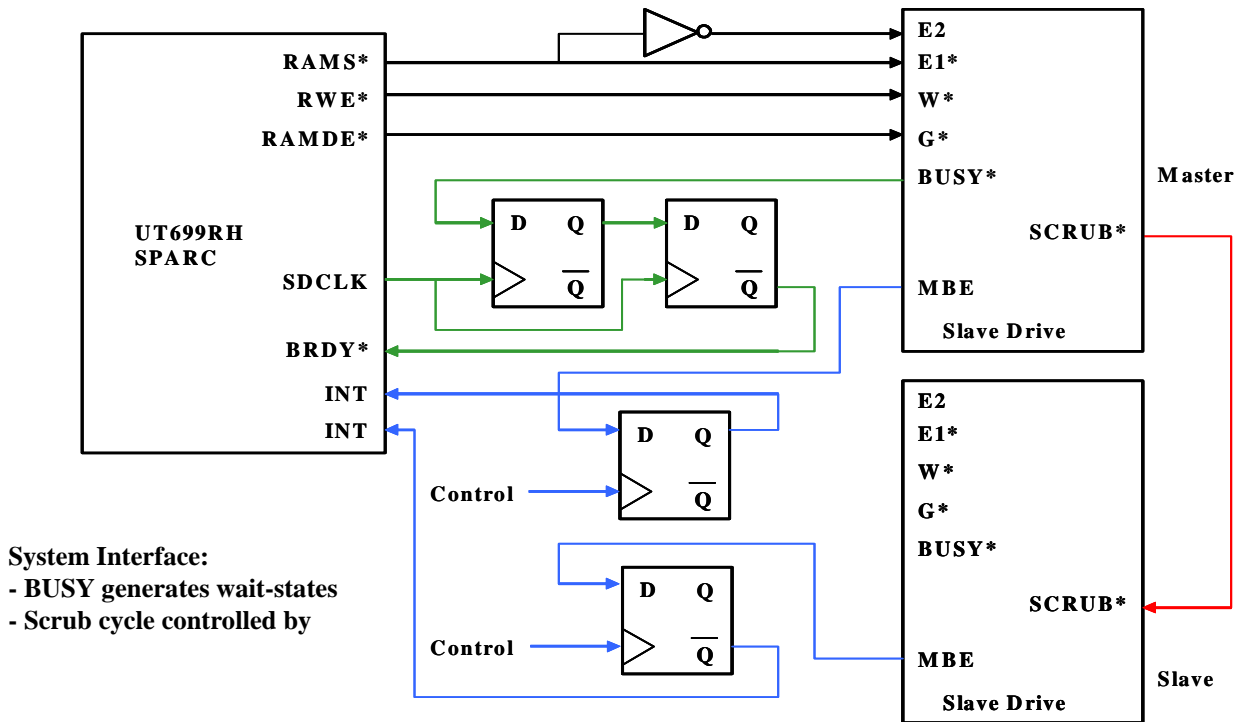

Figure 1. SPARC System Utilizing Master/Slave SRAMs with Auto-Scrub and Wait States

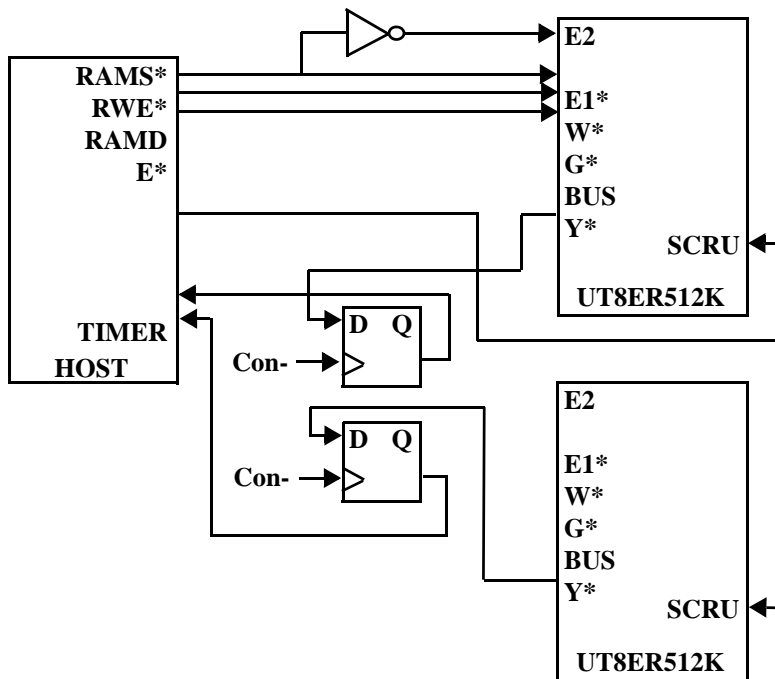

Figure 2. Slave Devices with Scrub-on-Command

16M SRAM Comparison to 4M SRAM

Design Factor	Industry Standard 4M SRAM	Aeroflex 16M SRAM
SEU Error Rate (errors / bit day)	1.10⁻¹⁰	6x10⁻¹⁶ ⁽⁴⁾
Total Power Dissipation (16Mbit solution)	1.5W ^(1,2)	0.6W ^(1,3)
Total Land Area (16Mbit solution)	4.8 sq-in ⁽²⁾	3.0 sq-in ⁽³⁾

(1) Operating at 25 MHz and 125°C, V_{DD} = 3.3V

(2) Assumes four 4M memory devices

(3) Including 1.8V linear regulator

(4) Error rate assumes default 156KHz scrub frequency+

Value Proposition of RadHard 16M Monolithic SRAM

No need for external EDAC memory bits

Improved system speed

Reduces memory power consumption by 60% savings over individual components

Lower system cost (16M ASP is 2.5x a 4M)

40% area savings over 4M SRAMs using offchip EDAC device

Increased bits per square inch

Fast access time (50MHz operation)

Internet Resources:

Visit www.aeroflex.com/RadHardSRAM to download:

RadHard SRAM Data Sheets

Applications Notes

IBIS Models

Tutorial "How to Design with the RadHard 16M Monolithic SRAM"

Visit www.aeroflex.com/RadHard to see the latest
Aeroflex Colorado Springs' RadHard products for space applications!

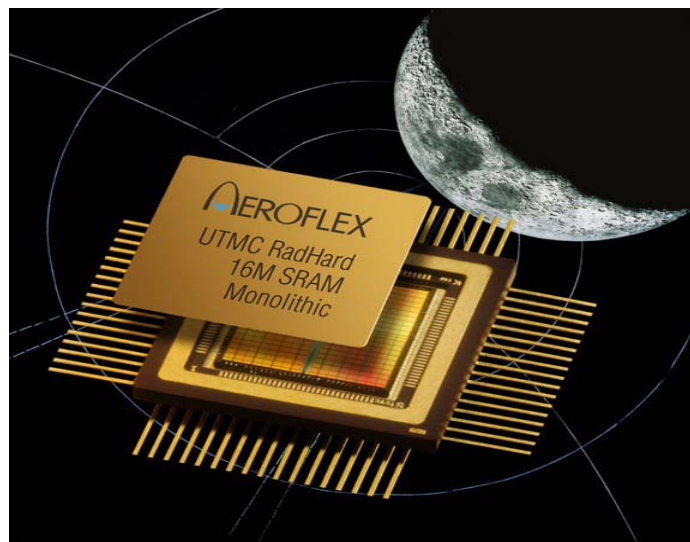

COLORADO

Toll Free: 800-645-8862

Fax: 719-594-8468

INTERNATIONAL

Tel: 805-778-9229

Fax: 805-778-1980

NORTHEAST

Tel: 603-888-3975

Fax: 603-888-4585

SE AND MID-ATLANTIC

Tel: 321-951-4164

Fax: 321-951-4254

WEST COAST

Tel: 949-362-2260

Fax: 949-362-2266

CENTRAL

Tel: 719-594-8017

Fax: 719-594-8468

www.aeroflex.com info-ams@eroflex.com

Aeroflex Colorado Springs, Inc., reserves the right to make changes to any products and services herein at any time without notice. Consult Aeroflex or an authorized sales representative to verify that the information in this data sheet is current before using this product. Aeroflex does not assume any responsibility or liability arising out of the application or use of any product or service described herein, except as expressly agreed to in writing by Aeroflex; nor does the purchase, lease, or use of a product or service from Aeroflex convey a license under any patent rights, copyrights, trademark rights, or any other of the intellectual rights of Aeroflex or of third parties.



Our passion for performance is defined by three attributes represented by these three icons: solution-minded, performance-driven and customer-focused