

Low Power SRAM Read Operations

Table 1: Cross Reference of Applicable Products

Product Name:	Manufacturer Part Number	SMD #	Device Type	Internal PIC Number:*
4M Asynchronous SRAM	UT8R128K32	5962-03236	01 & 02	WC03
4M Asynchronous SRAM	UT8R512K8	5962-03235	01 & 02	WC01
16M Asynchronous SRAM	UT8CR512K32	5962-04227	01 & 02	MQ08
16M Asynchronous SRAM	UT8ER512K32	5962-06261	05 & 06	WC04/05
4M Asynchronous SRAM	UT8Q512E	5962-99607	05 & 06	WJ02
4M Asynchronous SRAM	UT9Q512E	5962-00536	05 & 06	WJ01
16M Asynchronous SRAM	UT8Q512K32E	5962-01533	02 & 03	QS04
16M Asynchronous SRAM	UT9Q512K32E	5962-01511	02 & 03	QS03

* PIC = Aeroflex's internal Product Identification Code

1.0 Overview

The purpose of this application note is to discuss the Aeroflex SRAMs low power read architecture and to inform users of the affects associated with the low power read operations.

2.0 Low Power Read Architecture

The aforementioned Aeroflex designed SRAMs all employ an architecture which reduces power consumption during read accesses. The architecture internally senses data only when new data is requested. A request for new data occurs anytime the chip enable device pin is asserted, or any of the device address inputs transition states while the chip enable is asserted. A trigger is generated and sent to the sensing circuit anytime a request for new data is observed. Since several triggers could occur simultaneously, these triggers are wire-ORed to result in a single sense amplifier activity for the read request. This design method results in less power consumption than designs that continually sense data. Aeroflex's low power SRAMs listed above activate the sensing circuit for approximately 5ns whenever and access is requested, thereby, significantly reducing active power.

2.1 The SRAM Read Cycles.

The data sheets for all the devices noted in Table #1 discuss three methods for performing a read operation. The two most common methods for reading data are an Address Access and a Chip Enabled-Controlled Access. The third access discussed is the Output Enable-Controlled Access. The sequence at which control lines and address inputs are toggled determines which cycle is considered relevant. As discussed in section 2.0, an assertion of chip enable or any address transition while chip enable is asserted, initiates a read cycle. If the device chip enable is asserted prior to any address input transitions, then the read access is considered an Address Access. By keeping the device enabled and repeatedly switching address locations, the user retrieves all data of interest. A Chip Enable-Controlled Access occurs when the address signals are stable prior to asserting the chip enable. The Output Enabled-Controlled Access requires that either an Address Access or Chip Enable-Controlled Access has already been performed and the data is waiting for the Output Enable pin to assert, driving data to the device I/O pins.

The subsequent read cycle verbiage and diagrams are based on the Aeroflex UT8R512K8 data sheet. The number of control, input, and I/O pins will vary across the products listed in Table 1. The basic design family functionality for read operations is common among all the devices.

2.1.0 Address Access Read Cycle

The Address Access is initiated by a change in address inputs while the chip is enabled with \overline{G} asserted and \overline{W} deasserted. Valid data appears on data outputs DQ(7:0) after the specified t_{AVQV} is satisfied. Outputs remain active throughout the entire cycle. As long as chip enable and output enable are active, the address inputs may change at a rate equal to the minimum read cycle time (t_{AVAV}).

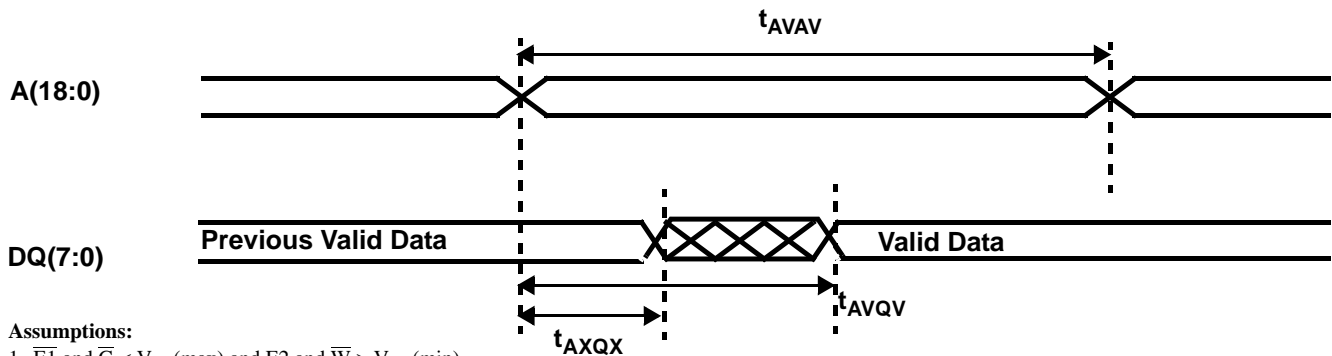

Assumptions:

1. $E1$ and $\overline{G} \leq V_{IL}$ (max) and $E2$ and $\overline{W} \geq V_{IH}$ (min)

Note: No time references are relevant with respect to Chip Enable(s). Chip Enable(s) is assumed to be asserted.

SRAM Read Cycle 1: Address Access

2.1.1 Chip Enable-Controlled Read Cycle

The Chip Enable-controlled Access is initiated by $\overline{E1}$ and $E2$ going active while \overline{G} remains asserted, \overline{W} remains deasserted, and the addresses remain stable for the entire cycle. After the specified t_{ETQV} is satisfied, the eight-bit word addressed by A(18:0) is accessed and appears at the data outputs DQ(7:0).

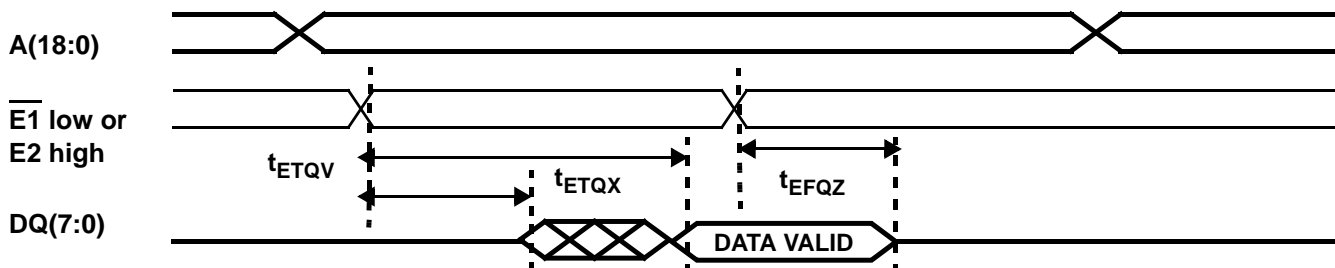

Assumptions:

1. $\overline{G} \leq V_{IL}$ (max) and $\overline{W} \geq V_{IH}$ (min)

Note: No specification is given for address set-up time with respect to chip enable assertion. The read cycle description states that addresses are to remain stable for the entire cycle. Address set-up time relative to chip enable is assumed to be 0ns minimum.

SRAM Read Cycle 2: Chip Enable Access

2.1.1 Output Enabled-Controlled Read Cycle

The Output Enable-controlled Access is initiated by \overline{G} going active while $\overline{E1}$ and E2 are asserted, \overline{W} is deasserted, and the addresses are stable. Read access time is t_{GLQV} unless t_{AVQV} or t_{ETQV} have not been satisfied.

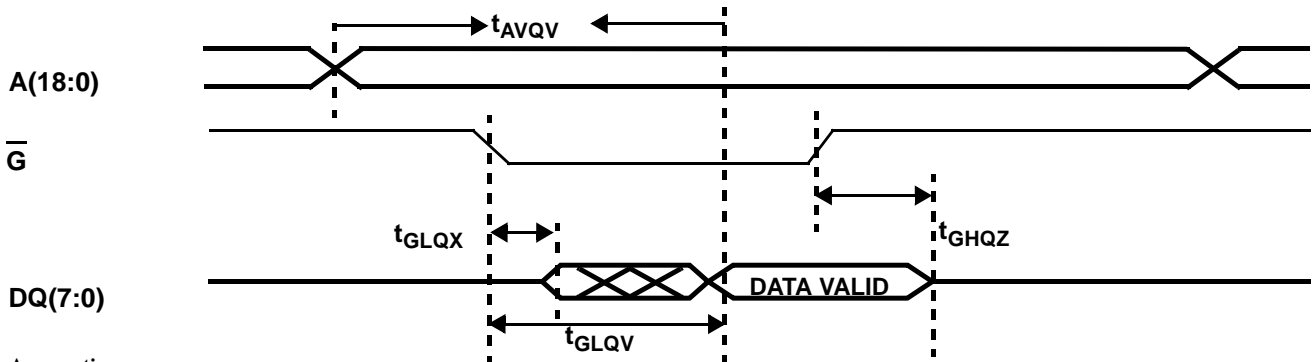

Assumptions:

1. $\overline{E1} \leq V_{IL}(\text{max})$, $E2 >$ and $\overline{W} \geq V_{IH}(\text{min})$

SRAM Read Cycle 3: Output Enable Access

3.0 Low Power Read Architecture Timing Consideration

The low power read architecture employed by Aeroflex designed SRAMs results in significant power reduction, especially in applications with longer than minimum read cycle times. However, this type of architecture is responsive to excessive input signal skew when device addressing and chip enable assertion occur simultaneously. Signal skew of greater than 4-5ns between all of the read triggering activities is sufficient to start another read cycle.

3.1 Simultaneous Control and Address Switching

Simultaneous switching of controls and address pins, alone, is not a problem; excessive skew between them is the concern. Consider the application where several SRAM devices are connected to the same memory bus. The address bus is commonly connected to all the devices, but the chip enable pin is singularly connected to each individual SRAM. This configuration results in a loading difference between the address inputs and the chip enable. This lightly loaded chip enable propagates to the memory more quickly than the heavily loaded address lines. The oscilloscope capture of Figure #1 is the actual timing of an application which had intermittent data errors due to address transitions lagging chip enable.

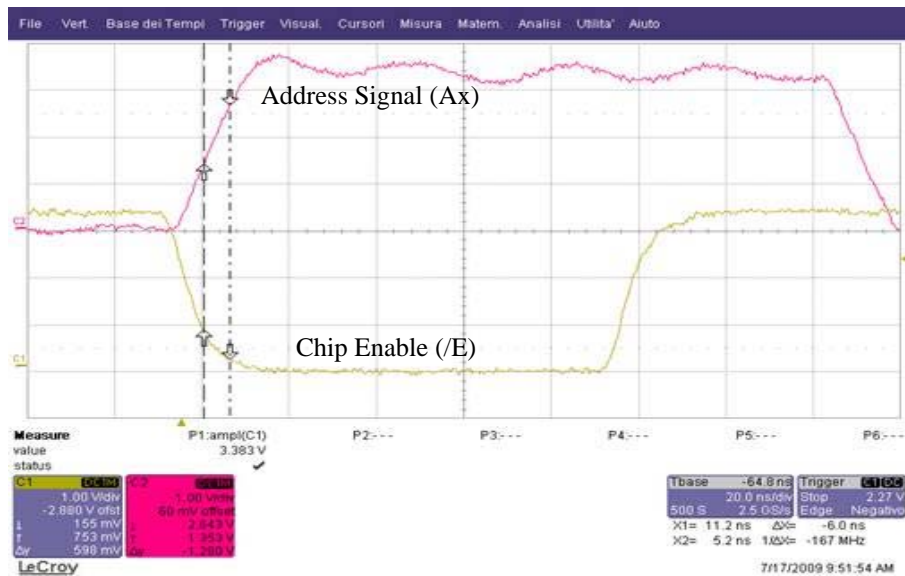

- Timing shown from VIL (yellow trace /CS) and VIH (pink for address signal) as delta X = 6ns. Even at actual internal gate switching point (~ VDD/2), the skew is still around 6ns.

Figure #1 SRAM Signal Capture

The signal transitions in the scope plot of Figure #1 appear to be fairly coincidental. A closer look however, reveals the chip enable signal actually starts and reaches V_{IL} approximately 6ns before the address signal reaches V_{IH} . Even at one half V_{DD} (closer to actual logical gate switching of the inputs), the delta in signal times is still approximately 6ns.

Simultaneous switching of controls and address inputs is not recommended for a couple of reasons. The first is the previously described signal skew sensitivity between controls and/or address inputs. The second reason is that activating all the controls and address inputs simultaneously results in peak instantaneous current consumption. This condition causes maximum strain to the power decoupling. Chip Enable activates address decoding circuits, address switching introduces input buffer switching current, and output enable assertion turns on all the device output drivers. Performing all three simultaneously results in worst case transient current demand by the memory.

3.1.0 Technical Overview of Skew Sensitivity

Recall from section 2.0 that any activity requesting new data causes a read trigger. The triggers are wire-ORed together. In order to meet the faster access times demanded by today's applications, the ORed trigger only exists during the first 4-5ns of the read cycle. Since the slowest of the address transitions occurs more than 5ns after the initiation of the read activity, a second read activity is initiated. The sensing circuit does not have time to normalize before the second read activity has started. For this reason a Chip Enable-Controlled read cycle requires that address inputs remain stable for the entire cycle. Infrequent and random sensing errors can result if the bit columns are continually pulled to one state then quickly requested to sense the opposite state. Another effect of the low power read architecture that differs from previous generation designs (those that continually sense for data) is that the bit line will not be sensed again until another read triggering event occurs. If another read trigger event (chip enable assertion and/or address change) does no occur for a particular address, the incorrect data remains at the outputs.

4.0 Summary and Conclusion

The Aeroflex SRAMs in Table #1 all employ a low power consumption read architecture. Power is conserved by sensing data only when new data is requested. A request occurs anytime chip enable is asserted or any address input signal transitions while chip enable is asserted. The data sheets for the SRAMs listed in Table #1 do not explicitly define the case of simultaneous switching of address and control signals during read operations. Data sheet read cycle descriptions indicate that control inputs are established prior to address changes, and address inputs are stable prior to control assertions. Simultaneous switching of addresses and controls is tolerable, when the skew between all input signals is $< 4\text{ns}$. For designs that must employ the simultaneous activation of address and control signals, two important issues should be considered by the designer. The first is the input signal skew sensitivity of the low power read architecture discussed by this application note. The second is the instantaneous current consumption that results from simultaneous access methods. Aeroflex recommends the use of only one read access method at a time. If multiple read accesses (simultaneous chip enable assertion and address switching) cannot be avoided, then Aeroflex recommends that the chip enable signal be delayed until all addresses have completed transitions.