

# Operation & Installation Manual



## Model 8314-X WLAN Simulator Subsystem (P/N 193-8132-X)

*This documentation may not be reproduced in any form, for any purpose unless authorized in writing by Aeroflex / Weinschel, Inc.*



© Aeroflex / Weinschel, Inc.  
Frederick, Maryland  
2008

# SAFETY SUMMARY

## DEFINITIONS.

The following definitions apply to WARNINGS, CAUTIONS, and NOTES found throughout this manual.



An operating or maintenance procedure, practice, statement, condition, etc., which, if not strictly observed, could result in injury and/or death of personnel. Do not proceed beyond a WARNING symbol until all the indicated conditions have been fully understood and/or met.



An operating or maintenance procedure, practice, statement, condition, etc., which, if not strictly observed, could result in damage or destruction of the equipment or long-term health hazards to personnel. Do not proceed beyond a CAUTION symbol until all the indicated conditions have been fully understood and/or met.

## **NOTE**

An essential operating or maintenance procedure, condition, or statement that must be highlighted.

## GENERAL PRECAUTIONS.

The following are general precautions that are not related to any specific procedure and, therefore, do not appear elsewhere in this publication. These are precautions that personnel must understand and apply during various phases of instrument operation or service.



- Potentially lethal voltages are present in this instrument. Serious shock hazards from voltages above 70 volts may exist in any connector, chassis, or circuit board. Observe the following precautions:

- To minimize shock hazard, the instrument chassis must be connected to an electrical ground. Using the supplied three-conductor power cable ensures that the instrument can be firmly connected to the ac power source and electrical ground at a grounded power outlet. If using a 3-2 wire adapter be sure to connect the ground lead to earth ground.
- Use the buddy system any time work involving active high voltage components is required. Turn OFF the power before making/breaking any electrical connection. Regard any exposed connector, terminal board, or circuit board as a possible shock hazard. DO NOT replace any component or module with power applied.
- If test conditions to live equipment are required, ground the test equipment before probing the voltage or signal to be tested.
- Personnel working with or near high voltage should be familiar with modern methods of resuscitation.
- DO NOT wear jewelry (rings, bracelets, metal watches, and/or neck chains) while working on exposed equipment. Be very cautious about using hand tools near exposed backplanes, bus bars, and/or power supply terminals. Use properly insulated tools. When making test connections to the power supply terminals and bus bars, use only insulated probe tips.
- Verify that the instrument is set to match the available line voltage and the correct fuse is installed.
- DO NOT install substitute parts or perform any unauthorized modification to this instrument. Contact Weinschel Corporation to acquire any information on replacement parts or returning the instrument for repair. Unauthorized modification can cause injury to personnel and/or destruction of the instrument.
- Operating personnel must not remove instrument covers. Component replacement or adjustments MUST BE performed by qualified service personnel.
- DO NOT operate the instrument near or in the presence of flammable gases or fumes.

## DETAILED PRECAUTIONS.

The following WARNINGS, CAUTIONS and NOTES appear throughout the text of this manual and are repeated here for emphasis.



**CAUTION**

- All procedures and/or steps identified as  must be followed exactly as written and according to industry accepted ESDS device handling procedures. Failure to comply WILL RESULT in ESDS damage.
- DO NOT use a nylon bristle brush in the solvent as the bristles may dissolve and cause damage to the circuit card or component.
- DO NOT use ultrasonic cleaning on parts or assemblies containing electrical or electronic components.
- DO NOT bend pins of electrical connectors when using fiber-bristle brush.
- Compressed air used for cleaning and/or drying can create airborne particles that may enter the eye. Goggles/faceshields should be worn. DO NOT direct air stream towards self or other personnel. Pressure should be restricted to a maximum of 15 psi to avoid personal injury.
- Under no circumstances should a wire brush, steel wool, or abrasive compound be used on any surface. Using these items will cause extensive damage to the instruments surface.

**NOTE**

DO NOT return any instrument or component to Weinschel Corporation without receiving prior factory authorization.

**SAFETY SYMBOLS.**

The following symbols are used to identify safety hazards found throughout this publication and/or located on the instrument.

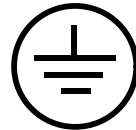
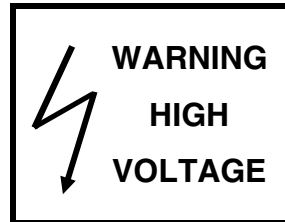

# TABLE OF CONTENTS

- 1. GENERAL INFORMATION.....4-7
  - 1-1. PURPOSE ..... 4
  - 1-2. SCOPE ..... 4
  - 1-3. EQUIPMENT DESCRIPTION ..... 4
  - 1-4. UNPACKING AND INSPECTION ..... 4
  - 1-5. RESHIPMENT INSTRUCTIONS ..... 5
  - 1-6. STORAGE INSTRUCTIONS ..... 5
  - 1-7. RELATED MANUALS ..... 6
  - 1-8. ELECTROSTATIC DISCHARGE SENSITIVE..... 6
  - 1-9. SAFETY CONSIDERATIONS..... 6
  - 1-10. POWER REQUIREMENTS ..... 6
- 2. FRONT & REAR PANEL CONNECTORS & INDICATORS .....7-11
  - 2-1. POWER ENTRY MODULE ASSEMBLY ..... 7-8
  - 2-2. MOBILE & BASE STATION PORT CONNECTORS ..... 8
  - 2-3. FRONT PANEL LEDS ..... 8
  - 2-4. EXTERNAL CONTROLS (REAR-PANEL BNC) ..... 8
  - 2-5. ETHERNET CONTROLLER LEDS & HARDWARE SETTINGS ..... 8-11
    - 2-5-1. STATUS LEDS ..... 8
    - 2-5-2. HARDWARE CONFIGURATION SWITCH SETTINGS ..... 9-10
    - 2-5-3. CONNECTOR PINOUTS ..... 11
- 3. COMMUNICATIONS ..... 12
- 4. SIMULATION PARAMETERS & OVERVIEW ..... 13-14
- 5. PROGRAMMING..... 15-23
  - 5.1. SIMULATION PARAMETERS ..... 15-17
  - 5.2. SIMULATION CONTROL ..... 18-19
  - 5.3. SIMULATION DATA/DIRECT IO ..... 20-24
  - 5.4. NETWORK CONTROL..... 24-25
  - 5.5. HARDWARE CONTROL..... 25
  - 5-6. DATA STORAGE..... 26
- 6. MAINTENANCE..... 28-30
  - 6-1. INSPECTION..... 28
  - 6.2. PREVENTIVE MAINTENANCE..... 28
  - 6.3. SPECIAL CLEANING INSTRUCTIONS ..... 28
    - 6-3.1. MICROWAVE COAXIAL CABLE ASSEMBLIES ..... 28
    - 6-3.2. CIRCUIT CARDS AND MODULES ..... 28
    - 6-3.3. MACHINED SURFACES AND HARDWARE ..... 29
    - 6-3.4. CHASSIS CLEANING..... 29
    - 6-3.5. CONNECTOR CLEANING..... 29
  - 6.4. LINE VOLTAGE FUSE REPLACEMENT ..... 30

---

7. REPLACABLE PARTS LIST.....	31
7-1. UNDERSTANDING REFERENCE DESIGNATORS .....	31
7-2. ORDERING INFORMATION.....	31
7-3. DRAWING NUMBER.....	31
7-4. REPLACABLE PARTS LIST.....	31
7-4.1. REFERENCE DESIGNATOR .....	31
7-4.2. DESCRIPTION .....	31
7-4.3. PART NUMBER.....	31
7-4.4. VENDOR PART NUMBER .....	31
7-5.5. CAGE CODE .....	31
7-4.6. ASSEMBLY AND COMPPONET LOCATION .....	31
8314-1 WLAN SIMULATOR SUBSYSTEM REPLACEABLE PARTS LIST (P/N 93-8132-1).....	32-33
8314-2 WLAN SIMULATOR SUBSYSTEM REPLACEABLE PARTS LIST (P/N 93-8132-2).....	34-35
8. CONTACTING AEROFLEX / WEINSCHEL .....	36
9. AEROFLEX / WEINSCHEL WARRANTY .....	36
10. ASSEMBLY/WIRING DIAGRAMS	
MODEL 8314-1 ASSEMBLY DRAWING.....	193-8132-1
MODEL 8314-2 ASSEMBLY DRAWING.....	193-8132-2
MODEL 8314-1 WIRING DIAGRAM .....	193-8133
MODEL 8314-2 WIRING DIAGRAM .....	193-8134
MODEL 8314-1 INTERFACE CONTROL DRAWING (SPECFICATIONS).....	089-4037
MODEL 8314-2 INTERFACE CONTROL DRAWING (SPECIFICATIONS) .....	089-4038

## 1. GENERAL INFORMATION:

**1-1 PURPOSE:** This manual contains setup and operation information for the Aeroflex / Weinschel's 8314 WLAN Simulator Subsystem (P/N 193-8132-X). The manual also provides component location, reference designators, part numbers, and nomenclature to identify all the assemblies and sub-assemblies of the WLAN Simulator Subsystem.

**1-2 SCOPE:** This manual is to be used in conjunction with the operation and maintenance of a 8314 WLAN Simulator Subsystem. The manual also provides a description of each assembly; assembly parts list; block diagrams; and general maintenance procedures to maintain the instrument.

**1-3 EQUIPMENT DESCRIPTION:** The WLAN Simulator Subsystem (8314) is available in two frequency ranges and is used to simulate the connectivity between a mobile running along a line of 3 base stations. Each of the three base stations have an individually controlled attenuator, which are then combined, and passed thru a fourth attenuator used to set the offset level. The attenuators are digitally controlled pin-diode absorptive attenuators, with a range of 0-63.75 dB in 0.25 dB steps. Refer to the RF Block Diagram below:

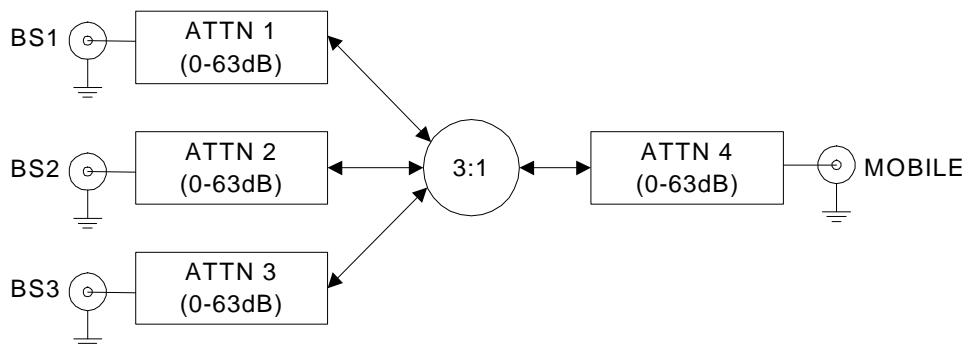

**1-4. UNPACKING AND INSPECTION:** Upon unpacking the equipment, retain the shipping container and packing material for future shipment for recalibration. Perform the following initial inspection:

- a. Carefully look at the outside of the shipping container for discoloration, stains, charring, or other signs of exposure to excessive heat, moisture, or liquid chemicals. Check for any physical damage to the shipping container such as dents, snags, rips, crushed sections or areas, or similar signs of excessive shock or careless handling.
- b. With the equipment and any accessory package removed from the shipping container, check each item against the packing list or Items Supplied List. If any items are missing, contact the Aeroflex / Weinschel Corporation Customer Service Department.
- c. Carefully inspect the equipment looking for dents, deep scratches, damaged or loose connector, or any other
- d. signs of physical abuse or careless handling. If damage is found, forward an immediate request to the delivering carrier to perform an inspection and prepare a concealed-damage report. DO NOT destroy any packing material until it has been examined by an agent of the carrier. Concurrently, report the nature and extent of damage to Weinschel Corporation, giving equipment model and serial numbers, so that necessary action can be taken. Under U.S. shipping regulations, damage claims must be collected by the consignee; DO NOT return the equipment to Aeroflex / Weinschel, Inc. until a claim for damages has been established.

**1-5. RESHIPMENT:** Use the best packaging materials available to protect the unit during storage or reshipment. When possible, use the original packing container and cushioning material. If the original packing materials are not available, use the following procedure:

- a. Wrap the storage cases in sturdy paper or plastic;
- b. Place the wrapped storage cases in a strong shipping container and place a layer of shock-absorbing material (3/4 inch minimum thickness) around all sides of the unit to provide a firm cushion and to prevent movement inside the container.
- c. If shipping the unit for service, attach a tag to indicate:
  1. model and serial numbers
  2. service required
  3. description of malfunction
  4. return address
  5. authorization to conduct repairs
  6. return authorization number
- d. Thoroughly seal the shipping container and mark it FRAGILE. Ship to:

**Aeroflex / Weinschel, Inc.**

Attn: Customer Service Department  
 5305 Spectrum Drive  
 Frederick, MD 21703-7362  
 or to an authorized sales representative.

**1-6. STORAGE:** Storage of the Model 8314 WLAN Simulator Subsystem is possible for extended periods without incurring damage to internal circuitry if the 8314 Series is packaged according to the instructions above. The safe limits for storage environment are as follows:

**Temperature:** 67° to +167 °F (-55° to +75 °C)  
**Humidity:** less than 95% without condensation  
**Altitude:** Up to 40,000 feet



**1-7. RELATED MANUALS:** The following manuals contain information that may be used in conjunction with this manual to operate, service, or calibrate this instrument.

<u>Manual</u>	<u>Title</u>
H4-1 and H4-2	Federal Supply Code for Manufacturers Cataloging Handbook

**1-8. ELECTROSTATIC DISCHARGE SENSITIVE:** The equipment documented in this manual contains certain Electrostatic Discharge Sensitive (ESDS) components or parts. Therefore, certain procedures/steps are identified by the use of the symbol . This symbol is used in two ways:



All procedures and/or steps identified as must be followed exactly as written and according to accepted ESDS device handling procedures. Failure to comply **WILL RESULT** in ESDS damage.

- a. When the ESDS symbol is placed between a paragraph number and title , all of that paragraph, including all subparagraphs, is considered ESDS device handling procedure.
- b. When the ESDS symbol is placed between a procedure/step number and the text , all of that procedure is considered an ESDS device handling procedure.

**1-9. SAFETY CONSIDERATIONS:** The WLAN Simulator Subsystem and all related documentation must be reviewed for familiarization with safety markings and procedures before any operation and/or service. Refer to the SAFETY SUMMARY located at the beginning of this manual for a summary of safety information and procedures. Following these simple safety precautions will ensure safe operation and service of the WLAN Simulator Subsystem.

**1-10. POWER REQUIREMENTS:** Aeroflex / Weinschel supplies a detachable power cable (P/N 068-21) to connect an 100 to 240 Vac power source with a frequency between 50 to 60 Hz to the WLAN Simulator Subsystem. To minimize shock hazard, the instrument chassis must be connected to an electrical ground. Using the supplied three-conductor power cable ensures that the instrument can be firmly connected to the ac power source and electrical ground (safety ground) at a grounded power outlet. Refer to paragraph 4-2 (Initial Setup) before applying any power to the instrument.

## 2. FRONT & REAR PANEL CONTROLS & INDICATORS:

The following paragraphs provide a description of the connections that can be made to the 8314 WLAN Simulator Subsystem. Figure 1 shows the location of these connectors.



Sufficient power levels are present at the Power Input Assembly to cause personal injury. Ensure that the instrument power cord is DISCONNECTED before attempting to change fuses.

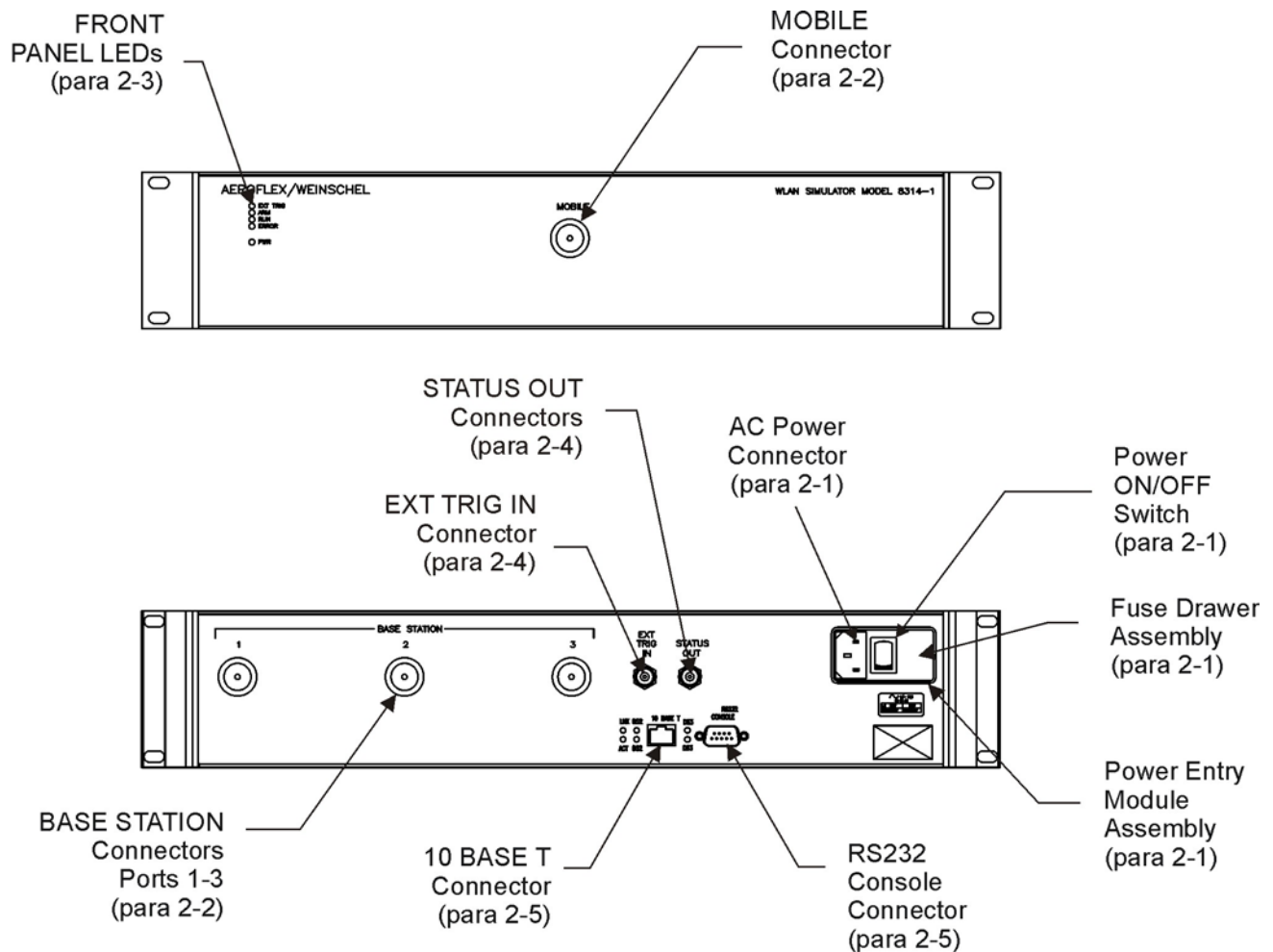

Figure 1. Front & Rear Panel Connectors & Indicators

**2-1 POWER ENTRY MODULE ASSEMBLY:** The Power Entry Module Assembly located on the rear panel contains a three-prong ac power input connector and a fuse drawer assembly (Figure 1). The **Fuse Drawer Assembly** contains the line voltage fuse (Aeroflex / Weinschel P/N 052-1-1.5). The Model 8314 uses a T 1.5A, 250 Vac fuse which is 5 x 20 mm in size. Refer to paragraph 8-XXX for replacement of the fuse.

The **AC Power Connector**, located on the left side of XF1 (Figure 1), is a plug-type, prong insert connector with three conductors for connection of the power cord (P/N 068-21) to the Power Supply Assembly located within the WLAN Simulator Subsystem. This connector also grounds the chassis of the WLAN Simulator Subsystem when the ac power cord is connected to a grounded wall outlet. If necessary, use a three prong to two prong adapter and connect the adapter's ground lead to the outlet plate retaining screw.

The **Power ON/OFF Switch** is located on the rear panel and in part of the Power Entry Module Assembly. Placing the POWER ON/OFF switch in the ON position applies power to the instrument.



**CAUTION**

When applying an RF signal to the RF INPUT connector, DO NOT exceed the maximum allowable power level specifications of the Model 8314.

**2-2. MOBILE & BASE STATION PORT CONNECTORS:** There are three BASE STATION Ports location on the rear panel and a Mobile Port on the front panel. These Type N female connectors provide a input and output ports where RF signals can be applied to the devices internally mounted in the Model 8314.

**2-3. FRONT PANEL LEADS:** There are four leds plus a PWR indicator which are shown on the front panel:

FP LED	FUNCTION
EXT TRIG	When on, the trig mode is set to external. When off, trig mode is internal.
ARM	When on, the system is awaiting a trigger event. Goes off when trig received.
RUN	System has been triggered and is running. Goes out when sweep ends.
ERROR	One or more of the setup parameters is invalid, and unable to run.
PWR	Indicates that external power is applied to the unit.

**2-4. EXTERNAL CONTROL CONECTORS:** These BNC female connectors are located on the rear panel. The table below outlines each connector's parameters:

CONTROL CONNECTOR	PARAMETERS
EXT TRIG INPUT	TTL/CMOS compatible schmitt-trigger Max input voltage range: -0.5V to +5.5V High-level input voltage VIH: +2.1V minimum Low-level input voltage VIL: +0.5V maximum Internal 10 KΩ resistive pullup to +5V ESD and current limit protected Programmable polarity
STATUS OUTPUT (simulation RUN state)	High-level output voltage VOH +4.8V @ IOH=-50µA (RUNNING) +3.2V @ IOH=-5mA Low-level output voltage VOL +0.2V @ IOL=50µA (STOPPED) +1.4V @ IOL=5mA ESD and current limit protected

**2-5. ETHERNET CONTROLLER LED's & HARDWARE SETTINGS:** The following paragraphs provide a description for each of the rear panel Ethernet LEDs, hardware settings for the internal Ethernet controller card and signal – pin locations for the 10BaseT and RS232 connectors. Figure 1 shows the location of these connectors.

**2-5.1 STATUS LEDs:**

LED	FUNCTION
SYS	Indicates that the Ethernet controller is enabled for operation in the system. This LED flashes during boot and remains on during normal operation of the switch.
ERR	Indicates that a serious error has occurred during system boot.
ACT	Indicates that activity is occurring over the 10BaseT Ethernet RJ-45 interface. This LED flashes as transmit/receive activity occurs.
LINK	Indicates that the Ethernet port has established a valid link with the network.
TX	This LED flashes as the Ethernet Controller transmits data via the RS232 Console port.
RX	This LED flashes as the Ethernet Controller receives data via the RS232 Console port

**2-5.2. Hardware Configuration Switch Settings:** Figure 2 is provided for component location for the switches, LEDs, connectors on the Ethernet controller card.

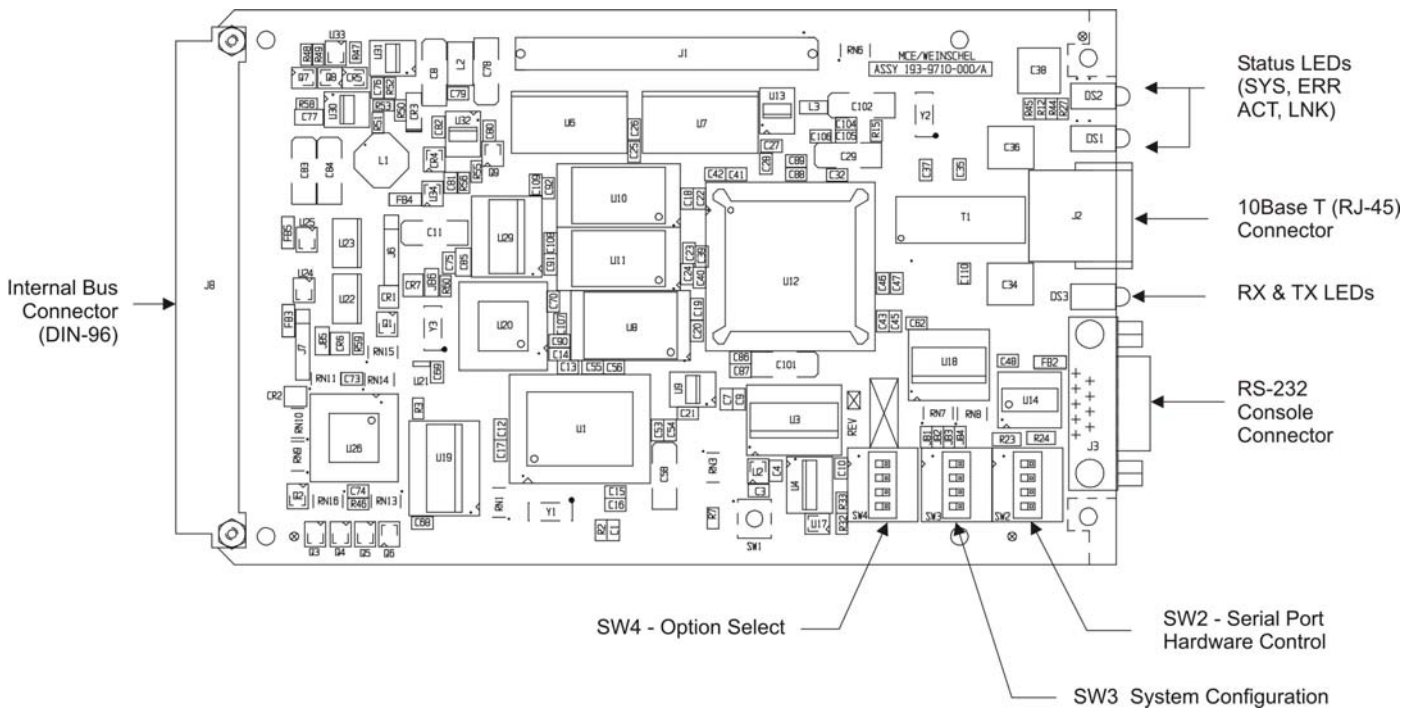

Figure 2. Ethernet Controller Card Switch/LED/Connector locations

**SW4 – Option Select**

	Name	Description	Default
1	---	unused	off
2	---	unused	off
3	BR1	Baud Rate Select  (see below)	off
	BR0	Baud Rate Select	off

**Baud Rate Select**

BR0	BR1	Rate
0	0	9600
1	0	19200
0	1	38400
1	1	57600

**SW3 – System Configuration**

	Name	Description	Default
1	MS1	Memory Select	off
2	MS2	Memory Select	off
3	LS2	Load Sequence Override (see below)	off
4	LS1	Load Sequence Override	off

**Memory Select**

MS1	MS2	Description
0	0	Normal
1	0	External ROM card
0	1	Emulation mode (reserved)
1	1	Emulation mode (reserved)

**Load Sequence Override**

LS1	LS2	Description
0	0	Normal sequence
1	0	run RomMon w/WDOG disabled
0	1	run SysLoader
1	1	Normal sequence w/WDOG disabled

**SW2 – Serial Port Hardware Control**

	Name	Description	Default
1	CTST	RS422 Mode CTS Termination Off – no termination On – 120 ohm termination	off
2	RXDT	RS422 Mode RXD Termination Off – no termination On – 120 ohm termination	off
3	RTSS	RS422 Mode RTS line Off – RTS+ not connected On – RTS+ connected	off
4	MODE	Serial Port Mode Off – RS232 On – RS422	off

**2-5.3 Connector Pinouts:** The Ethernet controller card contains a 10BaseT (RJ-45) and a RS232 (DB9M) Console connector that are mounted to the rear panel. There is also a table included for Internal Bus Connector, J8 located on the Ethernet Controller card (DIN-96). Pin-outs for these connectors are as follows:

**Serial Port Connector (DB9M)**

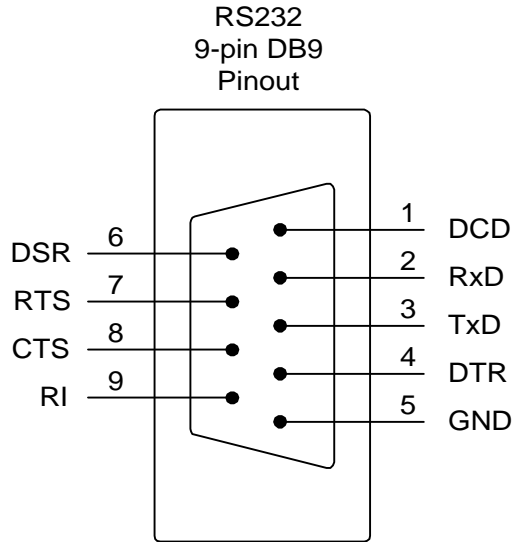

PIN NO	RS232	RS422
1	DCD (unused)	RXD+
2	RXD	RXD-
3	TXD	TXD-
4	DTR	TXD+
5	GND	GND
6	DSR (unused)	CTS+
7	RTS	RTS-
8	CTS	CTS-
9	RI (unused)	RTS+

**10Base-T Ethernet Port (RJ-45)**

PIN NO	10Base-T
1	TD+
2	TD-
3	RD+
4	Unused**
5	Unused**
6	RD-
7	Unused**
8	Unused**

\*\* Unused pins on the RJ-45 have 75Ω/0.01μF to chassis to reduce noise.

### 3. COMMUNICATIONS:

The system provides both RS-232 serial port and 10BaseT Ethernet operation.

The RS-232 port can operate at 9600, 19200, 38400, or 57600 baud rates, selectable via internal DIP switch. Default format is 9600N81. The serial port uses a standard DB9 DTE connector pinout. Connection to a standard PC's serial port requires the use of a "null-modem" type cable to swap the transmit and receive data pair (pins 2 and 3). A command-line interface (CLI) will be provided for interactive use w/ a terminal emulator. The CLI can be disabled to facilitate use of the serial port as a programming interface. The CLI provides user prompts and supports simple line editing (via the BS key) , last command recall (Ctrl-P), and a simple help facility. Help can be accessed from the main command prompt using either the HELP or simply '?'. Additional help for many commands is available by specifying the main command followed by a '?'. For example, "SET ?" provides a list of the SET commands, and "SET FREQ ?" provides detailed info on the set frequency command.

Many commands and keywords allow abbreviated forms. Command abbreviations can be displayed using the 'CMD ?' help command. Also, there are some system level configuration/diagnostic commands, such as PING, that can be listed using 'SYS ?' help command. Many of these require system-level password access.

10BaseT Ethernet will provide TELNET access (port 23) to the CLI for operation over a network. In addition, TFTP client will also be supported for performing code updates to the flash memory. Network parameters (IP address, subnet mask, TFTP host address, etc) can be set and stored/recalled from non-volatile memory. TFTP transfer is also used to support the download/upload of the raw data tables, due to the potential volume of information to be transferred. By default, the unit is configured for an IP address of 10.0.0.1, with a subnet mask of 255.255.255.0.

#### A NOTE ON PASSWORDS

Passwords are/can be used to prevent inadvertent configuration/switch changes. Password protection is, generally, weak, in that a user can see the current password using the 'SHOW CONFIG' command. In addition, there is a fixed password (the word SYSTEM) that can be used that will grant system-level access to many commands normally reserved for system testing/configuration.

### 4. SIMULATION PARAMETERS AND OVERVIEW:

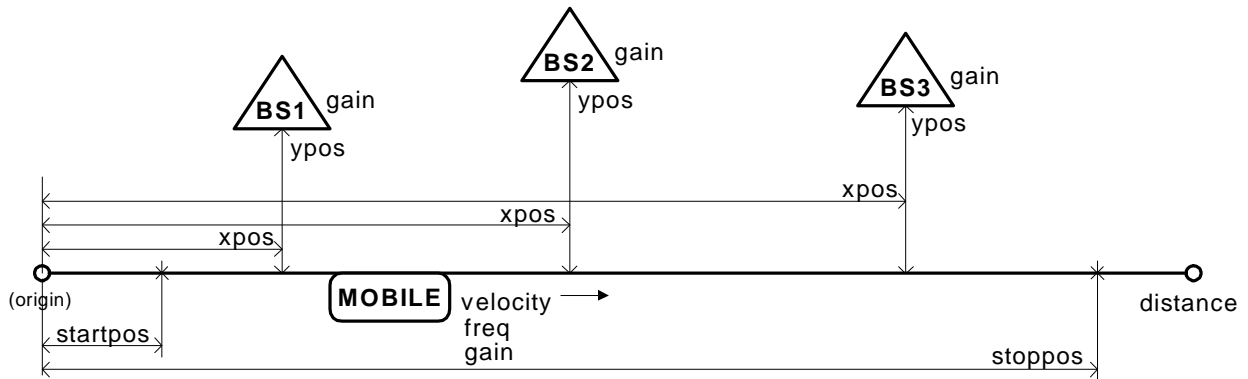

The above diagram shows the user-entered parameters. When a simulation is initiated, the parameters are validated, and the system builds its tables of attenuation setting vs time using the following relationship (Friis Transmission Equation)

$$LinkLoss = \left( \frac{\lambda}{4\pi R} \right)^2 GtGr$$

where

$$R = \sqrt{ypos^2 + xpos^2} \quad \text{and} \quad \lambda = \text{wavelength}$$

The system allocates a maximum of 10,000 data points for each attenuator for use over the entire simulation time, for a total of 30,000 data points. The data tables are pre-built prior to the start of the simulation run, and typically takes 3-4 seconds to complete.

When computing the data tables, the system notes the maximum signal level computed over the course of the simulation, which will occur when the mobile position is at Xpos1, Xpos2, or Xpos3, depending on the basestation gain and Ypos settings. This level, along with the nominal insertion loss of the unit, is used to set the Offset Attenuator (ATTN4), whose value will not be changed over the course of the simulation. This offset will be subtracted from the loss calculations of the three base station attenuators ATTN1-ATTN3, allowing the full range of these attenuators to be used for the simulation in most cases. For basestation positions that are located far from the track, the Offset Attenuator alone may not provide the reqd amount of attenuation, and this must be taken into account. For example, for f=2000MHz, ypos=100m, the loss is 78dB. Since there's only 63dB range in ATTN4, the remaining 78-63=15dB will have to be provided by the BS attenuator.

Simulation time is controlled via a 16-bit hardware timer/counter with 100nsec resolution, which provides a max count time of 6.5536ms, with no pre/post-scaling. The actual required update rate is a function of the simulation distance, mobile velocity, and the maximum number of allocated data points. The distance and velocity determine the total simulation time:

$$Time = \frac{distance(m)}{velocity(m/s)}$$

The system enforces a maximum update rate of 1msec. If Time is less than 10 secs (10,000pts \* 1ms/pt), then the update rate is fixed at 1msec, and the array size is reduced to cover the required time. If Time is greater than 10 secs, the entire 10,000 points are used, and the update rate is adjusted to cover the total simulation time.

The system also supports a “raw data mode”, in which the data tables are filled via external file download. This allows the unit to support any arbitrary attenuation profile.

**Operational Notes:**

- set trigger mode  
triggering can be set for INTernal or EXTernal. Ext trig is indicated on front-panel led.
- set trig polarity  
external trig polarity can be set for active high (1) or active low (0) logic levels. Triggering is level-sensitive. Note that the EXT TRIG input is pulled high via a resistive pullup.
- set sweep mode  
the simulation sweep can be set for SINGLE or CONTinuous operation. In SINGLE mode, the simulation will be run one time when a trigger event occurs, and will then stop. In CONT mode, when the end of a simulation is reached, the simulation will be automatically restarted from the beginning, depending on the current trigger mode. If the system is set for external triggering, then the triggering subsystem is re-armed, and will wait for a new trigger event before continuing.
- set/show parameters  
All parameters will have commands to set and query their current setting, as well as to be able to restore the default settings. Summary commands will also be available to view multiple related settings.
- run/stop simulation control  
The RUN command initiates a simulation sweep. It performs the following:
  - 1). All parameters are reviewed for validity. Note that while all the values are range-checked when they are entered, some parameter values are coupled, and cannot be validated until all parameters are entered. An example of this is the mobile position vs mobile distance. If the parameter values result in an invalid simulation, the run is aborted and the front-panel ERROR led is illuminated.
  - 2). Assuming the parameters are valid, the attenuation vs time profile data is computed, and stored in internal tables. The triggering subsystem goes from the IDLE to the ARMED state, in which it waits for a trigger event to occur. The front-panel ARM led is illuminated.
  - 3). If the trig mode is set to INTernal, the triggering subsystem automatically transitions from the ARMED to the RUNNING state. For external triggering, the ARMED to RUNNING state transition occurs when the system detects the external trigger event. The front-panel RUN led is illuminated, and the external STATUS output is asserted high.
  - 4). Simulation runs, with the basestation attenuators (1-3) being updated periodically over the course of the simulation.
  - 5). When the end of the simulation is reached, if the sweep mode is SINGLE, then the simulation ends, the RUN led goes off, and the external STATUS output is low. Otherwise the triggering is rearmed, and the simulation goes to step 3. In the CONTinuous sweep mode, the simulation will be re-run until the STOP command is given.

---

## 5. PROGRAMMING:

**5-1. Simulation Parameters:** In general, parameter ranges have been set to cover most real-world (and some not so real) conditions. The simulation can be run over a 20km total distance (12.4 miles), at speeds up to 320km/hr (approx 200mph). The system will not attempt to limit the selection of parameters, with the exception that the mobile and basestation positions must be within the MOBILE DISTANCE (total simulation distance) setting. This allows the maximum flexibility, but note that it also allows the user to set up scenarios that are not very realistic, or that could result in extremely long simulation runs.

### SET BASESTATION POSITION

#### Syntax

```
SET BASESTATION POSITION <select> <xpos> <ypos>  
SET? BASESTATION POSITION <select>
```

#### Parameters

```
<select> basestation select (1-3)  
<xpos>   x-axis distance from the origin, in meters (0-20000)  
<ypos>   y-axis distance from the track, in meters (1-100)
```

#### Description

Sets the position of the selected basestation. The position along the X axis should be  $\leq$  the MOBILE DISTANCE setting. There are no restrictions on the order or positioning between the three base stations.

#### Example

```
SET BASESTATION POSITION 1 2500 50  
sets the position of basestation 1 to 2500 meters from the start, at an offset  
of 50 meters
```

### SET BASESTATION GAIN

#### Syntax

```
SET BASESTATION GAIN <select> <gain>  
SET? BASESTATION GAIN <select>
```

#### Parameters

```
<select> basestation select (1-3)  
<gain>   gain factor, in dB (-10.0 to +10.0)
```

#### Description

Sets the antenna gain factor, in dB, for the specified basestation.

#### Example

```
SET BASESTATION GAIN 1 -1.5  
sets the gain of basestation 1 to -1.5dB, providing loss
```

**SET MOBILE DISTANCE**

## Syntax

```
SET MOBILE DISTANCE <dist>  
SET? MOBILE DISTANCE
```

## Parameters

<dist> simulation distance, in meters (1-20000)

## Description

Sets the total distance travelled for the simulation. Setting this parameter will automatically reset the MOBILE POSITION to cover the distance specified

## Example

```
SET MOBILE DISTANCE 10000  
sets the distance to 10000 meters
```

**SET MOBILE VELOCITY**

## Syntax

```
SET MOBILE VELOCITY <vel>  
SET? MOBILE VELOCITY
```

## Parameters

<vel> velocity, in km/hr (1-320)

## Description

Sets the speed of the mobile, in kilometers/hr

**SET MOBILE GAIN**

## Syntax

```
SET MOBILE GAIN <gain>  
SET? MOBILE GAIN
```

## Parameters

<gain> gain factor, in dB (-10.0 to +10.0)

## Description

Sets the antenna gain factor, in dB, for the mobile.

## Example

```
SET MOBILE GAIN -1.5  
sets the gain of mobile to -1.5dB, providing loss
```

**SET MOBILE POSITION**

## Syntax

```
SET MOBILE POSITION <startpos> <stoppos>  
SET? MOBILE POSITION
```

## Parameters

```
<startpos> x-axis starting distance from the origin, in meters (0-20000)  
<stoppos> x-axis stopping distance, in meters
```

## Description

Sets the mobile start and stop position, relative to the origin. Normally, these values would be set to cover the MOBILE DISTANCE setting. This command allows the user to travel over a portion of the total simulation distance. Note that changing this setting has no effect on the actual simulation data or update rate, as the data is based on the entire distance.

**SET FREQ**

## Syntax

```
SET FREQ <mhz>  
SET? FREQ
```

## Parameters

```
<mhz> frequency, in MHz (2000-6000)
```

## Description

Sets the current operating frequency for use by the loss calculations.

**SHOW PARAM**

## Syntax

```
SHOW PARAM
```

## Description

Displays the current setting of all the user-entered simulation parameters.

**SAVE PARAM**

## Syntax

```
SAVE PARAM
```

## Description

Saves the current setting of all the user-entered simulation parameters into non-volatile memory. These settings will be recalled during next system bootup.

---

## 5-2. Simulation Control

### SET TRIGGER MODE

#### Syntax

```
SET TRIGGER MODE <mode>  
SET? TRIGGER MODE
```

#### Parameters

<mode> trigger mode, INT or EXT

#### Description

Selects internal or external triggering for the simulation. With internal triggering, the simulation runs automatically after a RUN command is received. When external triggering is selected, the simulation will wait for an external trigger event before the simulation starts.

### SET TRIGGER POLARITY

#### Syntax

```
SET TRIGGER POLARITY <pol>  
SET? TRIGGER POLARITY
```

#### Parameters

<pol> active level, 0 or 1

#### Description

Sets the external trigger polarity level. Setting <pol>=0 sets an active-low external trigger, while a <pol> of 1 sets an active-high trigger level. The external trigger input has a resistive pull-up, so that if trigger input is left unconnected it will default to a high level.

### SET SWEEP MODE

#### Syntax

```
SET SWEEP MODE <mode>  
SET? SWEEP MODE
```

#### Parameters

<mode> sweep mode, CONT or SINGle

#### Description

Sets the simulation sweep mode. In SINGLE mode, once a simulation is triggered the simulation will run once and then stop. If the sweep is set for CONTinuous operation, when the simulation reaches the end it will return to the armed state and await another trigger event.

### RUN

#### Syntax

```
RUN [CALC]
```

#### Description

Initiates/computes a simulation run. In its basic form, the RUN command computes the attenuator data tables based on the entered parameters, and places the triggering subsystem in the armed state, awaiting a trigger event. If the optional CALC switch is specified, the command will only perform the calculations, and will not arm the trigger. This is useful if the user desires to view the simulation results prior to actually running the simulation.

**STOP**

Syntax  
STOP

Description  
Stops a running simulation.

**SHOW CALC**

Syntax  
SHOW CALC

Description  
Displays various results of the simulation calculations, including total time, max levels, update rate, etc

**SHOW STATUS**

Syntax  
SHOW STATUS

Description  
Displays the current state of a simulation.

Sets the simulation sweep mode. In SINGLE mode, once a simulation is triggered the simulation will run once and then stop. If the sweep is set for CONTInuous operation, when the simulation reaches the end it will return to the armed state and await another trigger event.

---

### 5-3. Simulation Data/Direct IO

These commands provide access to the raw simulation data and control, and can be used to override or view the internal calculation data.

#### SET DATA CALC

Syntax

SET DATA CALC <mode>

Parameters

<mode> calc mode 0 or OFF, 1 or ON

Description

This command can be used to enable/disable the loss calculations. With calc off, the system allows the data tables to be filled with arbitrary data using the SET DATA, SET DATA TIMER, and SET DATA POINTS commands.

NOTE: this is not a new command, but it now allows use of the parameters ON and OFF instead of just 0/1

#### SET DATA POINTS

Syntax

SET DATA POINTS <numofpts>

Parameters

<numofpts> number of data points (1-10000)

Description

Sets the number of data points to use for a simulation run in table mode. Each point must be filled using the SET DATA command

#### SET DATA

Syntax

SET DATA <pt> <attn1> <attn2> <attn3>

Parameters

<pt> data point number (0-10000)

<attn1> attenuator 1 setting, in dB

<attn2> attenuator 2 setting, in dB

<attn3> attenuator 3 setting, in dB

Description

Sets a data point for use in table mode (DATA CALC 0). Data point 0 is the initial setting at time 0. The range of the attn setting is dependant on the attenuator configuration, but is typically 0 to 63.75 in 0.25dB steps. Note: Control of the Offset Attn (Attn4) setting may be done using the ATTN command

**SET DATA TIMER**

## Syntax

```
SET DATA TIMER <secs>
```

## Parameters

<secs> simulation update rate, in secs (0.001-60.000)

## Description

Sets the attenuator update rate in table mode. The total simulation time is determined from DATA TIMER \* DATA POINTS

**SHOW DATA**

## Syntax

```
SHOW DATA <startidx> <endidx> [FMT]
```

## Parameters

<startidx> starting data array index (0-10000)

<endidx> ending data array index (0-10000)

[FMT] optional formatting flag

## Description

Displays the simulation data array. The response shows the point number, and the data for each of the three attenuators at that point. The default format for the attenuation data is the integer programming word (0-255), which can be changed to display attenuation by using the optional FMT specifier

**ATTN**

## Syntax

```
ATTN <select> <setting>
```

```
ATTN? <select>
```

## Parameters

<select> attenuator select (1-4)

<setting> attenuation value, in dB (0-63.75)

## Description

Directly sets an attenuator setting. This command is useful for testing and diagnostics.

**SET OFFSET ATTN**

## Syntax

```
SET OFFSET ATTN <setting>
```

```
SET? OFFSET ATTN
```

## Parameters

<setting> attenuation value, in dB (0-63.75)

## Description

Sets the Offset Attenuator value. The dB value specified in <setting> will be rounded to the resolution of the attenuator. This command is useful for setting an offset while using Data Table mode, and is equivalent to the 'ATTN 4 xx' command.

**FILL DATA**

## Syntax

FILL DATA <setting>

## Parameters

<setting> attenuation value, in dB (0-63.75)

## Description

Fills the data tables with the specified db value.

**SHOW TIME**

## Description

Shows current system time in hrs:min:secs.msec and elapsed time since last invocation. Useful for timing script execution.

**SHOW ERROR COUNT**

## Description

Shows count of total errors since last invocation. Useful for script debugging.

**SHOW FILE**

## Syntax

SHOW FILE [DATAFLASH:]

## Description

This command can be used to display the status and contents of the dataflash: storage area (including the name and size) if the optional 'DATAFLASH:' or 'DF:' parameter is specified.

Otherwise, it displays the status of both the flash: and dataflash: file storage areas, including header information, crc's, version, date, size, etc.

The first line of each section contains status information for each copy in the form 'Status (backup copy, working copy)'. A status of 0 indicates the file is valid, while <0 indicates an error was detected in the copy. The remaining info is from the copy that is/will be in use. For example, flash: Status(-252, 0) indicates that there is a CRC error in the backup copy, while the working copy is ok.

**EXECUTE SCRIPT**

## Syntax

EXECUTE SCRIPT [ECHO]

## Description

This command executes the command script file stored in the dataflash: (df:) device. If the optional 'ECHO' keyword is provided, then the command will display the script on the current console device as it is executed.

The command script file may contain any executable command supported by the CLI. Lines are limited to 128 chars in length, and should end with an ascii CR (0x0d), LF (0x0a), or any combination of the two. Comment lines are optional, and if used must begin with either an ascii single-quote character (0x27), or an ascii '/' char (0x2f).

Script files are stored into the dataflash: using the COPY TFTP command, and are limited to a maximum total length of 512K bytes. The current contents of the dataflash: can be viewed using the SHOW FILE DF: command.

**COPY source destination**

## Syntax

```
COPY TFTP:<url-filename> {FLASH: | DATAFLASH:}
COPY {FLASH: | DATAFLASH:} TFTP:<url-filename>
```

Access-level : password

## Description

Copies remote file identified by <url-filename> via TFTP to/from application flash: or dataflash: memory. The first argument is the source, the second is the destination. It allows the user to download an image from the network and save in flash, or upload an image from flash to the network server. By default, the transfer uses the host IP address specified by SET TFTP\_HOST. However, if the <url-filename> contains an IP address, the transfer will use this address instead.

For example, 'copy tftp://10.0.0.10/file.bin flash:' would attempt to download the file from the specified address of 10.0.0.10, ignoring the current TFTP\_HOST setting, if any.

Each of the data storage devices only reserve space for a single file, so any downloads will overwrite the current contents. As such, any filename parameters for the fl: and df: destinations are used strictly as placeholders.

The command accepts the abbreviations of 'FL:' and 'DF:' for the flash: and dataflash: devices, respectively.

**ENABLE**  
**ENABLE PASSWORD**  
**DISABLE**

## Syntax

```
ENABLE
ENABLE <plain-text>
ENABLE PASSWORD <plain-text>
NO ENABLE PASSWORD
DISABLE
RECOVER PASSWORD
SHOW PASSWORD\0
```

see also: SET ACCESS SYSTEM

Access-level : all

## Description

The mrs software provides two levels of access to commands: user and privileged. The unprivileged user mode is called 'user exec' mode. The privileged mode is called 'privileged exec' mode and normally requires entry via a password. The commands available in 'user exec' mode are a subset of the commands available in 'privileged exec' mode.

The ENABLE and DISABLE commands are used to enter and leave privileged exec mode, respectively. If a password has been set, the user will be prompted to enter the password. Once entered, the prompt changes to 'mrs#' to show the current mode. You may bypass the 'password:' prompt by including the password along with the ENABLE keyword on the command line.

To set an access-level password, use the 'ENABLE PASSWORD <plain-text>' command, where <plain-text> specifies the desired password, and may be up to 11 chars in length. The password is stored in nvram. The command 'NO ENABLE PASSWORD' deletes the password and removes it from nvram storage, as long as you are in privileged mode.

There is a password recovery feature that allows the user to view/erase the current password without being in privileged mode. This can be accessed only via a local serial port connection to the console, and will not work over a telnet connection.

To erase the password, you must first send an RS232 BREAK signal. You should see the console respond with the message '\*\*BREAK\*\* detected. Password recovery enabled'. Once password recovery is enabled, you can use the 'SHOW PASSWORD' command to display the current password, or you can send 'RECOVER PASSWORD', which will erase the current password setting. If successful, you will get the message 'Password reset'. Password recovery mode is automatically terminated after receipt of any two CLI commands, after which you will get an 'Access denied' error, and have to repeat the steps.

## 5-4. Network Configuration

### SHOW NETWORK CONFIG

#### Syntax

```
SHOW NETWORK CONFIG
```

#### Description

Displays the current setting of the configuration parameters, including MAC and IP addresses, tftp host, password, etc.

### SET IP ADDRESS

#### Syntax

```
SET IP ADDRESS <ip-addr> [<subnet-mask>]
```

Access-level : password

#### Description

Sets the IP address of the ethernet interface to <ip-addr> with a network mask <subnet-mask>, if supplied. Both <ip-addr> and <subnet-mask> are in the form of A.B.C.D.  
By default, the IP address is 10.0.0.1, with a subnet mask of 255.255.255.0

### SET IP GATEWAY

#### Syntax

```
SET IP GATEWAY <ip-addr>
```

Access-level : password

#### Description

Sets the IP address of the default gateway used to access addresses outside the local subnet. The <ip-addr> parameter is in the form of A.B.C.D.  
Changes made to this parameter will not take effect until the system is rebooted (see RELOAD).

### SET TELNET TIMEOUT

#### Syntax

```
SET TELNET TIMEOUT <secs>
```

#### Description

Sets the inactivity timeout for TELNET sessions, in secs. <secs> can be in the range of 30 to 1800 (30 mins). The default timeout is 600 secs (10 mins).

**SET TFTPHOST**

## Syntax

```
SET TFTPHOST <ip-addr>
```

## Description

Sets the IP address for a remote TFTP server, which is used by the COPY cmd.

**PING**

## Syntax

```
PING <ip-addr>
```

## Description

Sends ICMP ECHO packets to <ip-addr>, and reports the results. The packets are 32 bytes in length.

**COPY source destination**

## Syntax

```
COPY TFTP:<url-filename> {FLASH: | BOOTFLASH:}
COPY {FLASH: | BOOTFLASH:} TFTP:<url-filename>
```

## Description

Copies remote file identified by <url-filename> via TFTP to/from application flash: or sysloader bootflash: memory. The first argument is the source, the second is the destination. It allows the user to download an image from the network and save in flash, or upload an image from flash to the network server. By default, the transfer uses the host IP address specified by SET TFTPHOST. However, if the <url-filename> contains an address, the transfer will use this address instead. For example, 'copy tftp://10.0.0.10/file.bin flash:' would attempt to download the file from the specified address of 10.0.0.10, ignoring the current TFTPHOST setting, if any.

**RELOAD**

## Syntax

```
RELOAD
```

## Description

Reboots the system, performing the boot-up sequence as if from power-up.

**5-5. Hardware Configuration**

CONFIG commands are typically used during system mfg and set up, and should not normally be changed by the user, unless instructed to do so. These commands require system-level access.

```
CONFIG ATTN <maxdb> <stepdb>
```

Sets the attenuator max setting and stepsize, in dB

```
CONFIG FREQ <minf> <maxf>
```

Sets the min and max freq range, in MHz

```
CONFIG LOSS <minl> <maxl>
```

Sets the insertion loss min and max (at min/max freq), in dB

```
SAVE CONFIG
```

```
SHOW CONFIG
```

## 5-6. Data Storage

The MRS has a new logical storage device referred to as the dataflash: ( or DF: ). While the dataflash: cannot be used to directly store the simulation data tables, the dataflash: can be loaded with a text script file that can be used for a variety of purposes. The script file can contain any sequence of commands that are recognized from the CLI, and can be executed on command much like a batch file. The dataflash: script file is loaded via downloading the file from a network TFTP server connection. Once copied, the file is stored in non-volatile memory on the controller and is automatically saved for future execution. The script file can then be executed via a CLI command. While the script file can contain any sequence, it is particularly useful for setting up the simulation data tables.

While the data tables can be loaded via cli commands, it can take a long time to send the sequence via the serial port or even a network telnet connection, especially for a large number of data points. Also, without the dataflash:, the data points are lost upon power-down. The dataflash: fixes these issues.

To use the dataflash:, you must create an ASCII text file that has the desired sequence of commands. The lines of the file should be limited to 128 characters in length, and terminated with an ASCII CR (0x0D) , LF (0x0A) or both. The file can contain empty (blank) lines for readability, and can also contain comments lines. Comment lines are those lines that begin with either a single slash character (0x2F) , a double slash, or a single quote (0x27) character.

Examples are shown below:

```

/ THIS IS A COMMENT
set data 1 12.45 13.45 13.45
// also a comment
set data 2 1.2 2.2 3.2
' YET ANOTHER COMMENT

```

There are no formal limits on the number of lines contained in a script file, but the file size must be limited to a maximum of 512K bytes to fit into the dataflash: storage area ( a typical 10,000 point data script file is roughly 324K in size). An example 10-point data file might look like:

```

// setup general simulation params
// turn off calculations (sets table mode)
set data calc off
// number of points
set data points 10
// update rate of 1ms per point
set data timer 0.001
// init the offset attn (#4)
set offset attn 10.5

// fill table with 0dB
fill data 0

// data points
set data 0 0.25 0.5 0.75
set data 1 1.25 2.25 3.25
set data 2 2.5 4.5 6.5
set data 3 3.75 6.75 9.75
set data 4 5 9 13
set data 5 6.25 11.25 16.25
set data 6 7.5 13.5 19.5
set data 7 8.75 15.75 22.75
set data 8 10 18 26
set data 9 11.25 20.25 29.25
set data 10 12.5 22.5 32.5

// comment end of file

```

Once the file has been created, the next step is to transfer it to the MRS. This is done via the network using the TFTP file transfer protocol. Place the file on a PC running a TFTP server that the MRS can communicate with. If you do not have a TFTP server, there are several freeware/open source packages available on the internet, such as tftpd32 (available at <http://tftpd32.jounin.net/>). The MRS contains a TFTP client that can be used to initiate the transfer from the CLI. Use the COPY command to perform the download to the MRS's dataflash: device. For example, if the tftp server is at address 10.100.103.100, and the file is named "example.txt" you could use the command:

```
mrs> copy tftp://10.100.103.100/example.txt df:
```

This should initiate the transfer, download, and store the file into the dataflash: device. Note: as shown above, the target name for the file in the dataflash: is optional. Since the dataflash: can only hold a single file, the name is used for information purposes only. The name, if provided, will be displayed via the

Once successfully transferred, the script file can be executed from the command line via the EXECUTE SCRIPT command, which will parse and execute the series of commands from the file, after which a short summary is displayed. If you would like to see the script as it executes, you can use EXECUTE SCRIPT ECHO, which is useful for finding errors in the script. You can display the contents of the dataflash: to the console using the command SHOW FILE DF: Once executed, the data table will contain the desired attenuation profile, and the simulation can be controlled via the normal RUN, STOP, etc commands.

Using the dataflash: to store the script is most useful for large data sets. After all, since the script file consists purely of executable commands, you could just send the contents of the script file via telnet for direct execution by the MRS, and this works fine for small data sets. It can be, in fact, faster to do this than to use COPY TFTP: and EXECUTE SCRIPT. Once the data set becomes larger, it's more efficient to transfer the file to the dataflash:. Some typical times vs file sizes are shown below

<b>Data points</b>	<b>Telnet transfer</b>	<b>Tftp transfer/execute</b>
100	2.2 sec	4 sec / 0.4 sec = 4.4 sec
500	9.1 sec	4.9 sec / 1.7 sec = 6.6 sec
1000	17.8 sec	5.9 sec / 3.3 sec = 9.2 sec
5000	88.2 sec	14.5 sec / 16.3 sec = 30.8 sec
10000	176.3 sec	26.4 sec / 32.5 sec = 58.9 sec

Also, once the file has been stored in the dataflash:, it can be used again the next time the unit is powered up simply by using the EXECUTE SCRIPT command, saving the time required to re-download the file.

You can also retrieve the contents of the dataflash: storage. The following command would create a file named "example.txt" on the TFTP server, and copy the contents of the dataflash: to it.

```
mrs> copy df: tftp://10.100.103.100/example.txt
```

## 6. MAINTENANCE:

The following paragraphs provide general inspection and maintenance guide lines for the Model 8314 WLAN Simulator Subsystem.

**6-1. INSPECTION:** Perform a visual inspection in conjunction with the maintenance activities schedule when a malfunction is suspected, or whenever an assembly is removed or replaced.

**6-2. PREVENTIVE MAINTENANCE:** While the 8314 requires very little preventive maintenance, it should not be subjected to physical abuse, severe mechanical shock, high humidity, or operating temperatures outside the specification range. The instrument should be kept free of excessive dirt and dust, since these can interfere with connector functions and with normal heat dissipation. For cleaning instructions refer to paragraph 6-3 (special cleaning instructions). The following paragraphs provide the preventive maintenance that is to be performed on the Unit.

Care should be taken to prevent strain on the interconnecting cables, since damage here may not always be apparent. Occasionally check the external cables and connectors for signs of cracked insulation and/or bent or worn pins. Tests show that connectors must be clean for accuracy and stability. This requires an inspection and cleaning of each connector immediately before use. For connector cleaning instructions, refer to paragraph 6-3. When cleaning precautions are observed regularly, connectors can maintain their stability for over several thousand connection cycles. Refer to Appendix A for more information about cables and connectors.

**6-3. SPECIAL CLEANING INSTRUCTIONS:** The cleaning procedures for 8314 are divided into five general groups: microwave coaxial cable assemblies, circuit card and modules; machined surfaces and hardware, chassis cleaning, and connector cleaning.

**6-3.1. MICROWAVE COAXIAL CABLE ASSEMBLIES:** Appendix A (located at the end of this manual) provides all the necessary procedures for care, cleaning, and handling of microwave coaxial cable assemblies.

**6-3.2 CIRCUIT CARDS AND MODULES:** A protective coating is applied to circuit cards for protection from moisture, arcing, short-circuiting, and abrasion. To remove light dirt from circuit cards and modules proceed as follows:



### CAUTION

- DO NOT use a nylon bristle brush in the solvent as the bristles may dissolve and cause damage to the circuit card or component.
  - DO NOT use ultrasonic cleaning on parts or assemblies containing electrical or electronic components.
  - DO NOT bend pins of electrical connectors when using fiber-bristle brush.
- a. Briskly brush isopropyl alcohol onto area to be cleaned with fiber-bristle brush.
  - b. Carefully remove residue with a clean lint-free cloth and repeat step "a" as a rinse.



### WARNING

Compressed air used for cleaning and/or drying can create airborne particles that may enter the eye. Goggles/ faceshields should be worn. DO NOT direct air stream towards self or other personnel. Pressure should be restricted to a maximum 15 psi to avoid personal injury.

- c. When parts are thoroughly clean, dry parts using 5 psi of clean moisture free compressed air or preferably dry nitrogen (pressurized spray will work well).

**6-3.3 MACHINED SURFACES AND HARDWARE:** To remove light dirt and dust from mechanical parts such as castings, covers and other hardware proceed as follows:

**WARNING**

Compressed air used for cleaning and/or drying can create airborne particles that may enter the eye. Goggles/ faceshields should be worn. **DO NOT** direct air stream towards self or other personnel. Pressure should be restricted to a maximum 15 psi to avoid personal injury.

**CAUTION**

- Under no circumstances use a wire brush, steel wool, or abrasive compound. Using these items will cause extensive damage to the instrument's surface.
  - **DO NOT** use a nylon bristle brush in solvent as the bristles may dissolve and cause damage to the circuit card or component.
- a. Use 5 psi of clean, moisture-free compressed air or preferably dry nitrogen to blow loose dirt and dust from surface of item.
  - b. Briskly brush isopropyl alcohol onto area to be cleaned with a fiber-bristle brush.
  - c. Remove residue with lint-free cloth and repeat step "b" as a rinse.
  - d. When parts are thoroughly clean, dry parts using 5 psi of clean, moisture-free compressed air or preferably dry nitrogen.
  - e. Clean smaller mechanical parts or hardware by dipping into a container of isopropyl alcohol. Remove dirt by brushing with fiber-bristle brush after parts have been immersed for several hours.
  - f. Remove parts from isopropyl alcohol and rinse by immersing into a different container of isopropyl alcohol.
  - g. When parts are thoroughly cleaned, dry parts using 5 psi of clean, moisture-free compressed air or preferably dry nitrogen.

**6-3.4 CHASSIS CLEANING:** Clean chassis using a lint-free cloth moistened with water and mild detergent. For harder to clean areas, such as inside corners of chassis, use a vacuum cleaner.

**6-3.5 CONNECTOR CLEANING:** Where small amounts of rust, corrosion, and/or oxide deposits are present on connectors, clean externally with a soft-bristle brush, aluminum wool, or internally with an acid brush; then wash with a non-corrosive solvent. MIL-C-83112 is recommended. Exercise care to ensure no metal filing or residue remains inside the connector and the connector is thoroughly dry. Where rust, corrosion, and/or oxide deposits are present in large quantities, replace the connector.

**6-4. LINE VOLTAGE FUSE REPLACEMENT:** The following steps provide procedures to replace the line voltage Fuse Assembly. This unit accepts a F1.5A, 250 Vac fuse for 115 Vac.

**WARNING**

Sufficient power levels are present at the Power Input Assembly to cause personal injury. Ensure that the instrument power cord is DISCONNECTED before attempting to change fuses.

**CAUTION**

DO NOT connect or apply power to this instrument until the Power Entry Module Assembly has been adjusted to the operational line voltage.

- a. Disconnect the power cord from the Power Entry Module Assembly.
- b. Use a small screwdriver to carefully open the Fuse Drawer.
- c. Slide out Fuse Drawer located in the center of the Power Entry Module Assembly.
- d. Remove defective fuse and replace with the correct fuse (Refer to applicable parts list for fuse part number).
- e. Snap the Fuse Drawer shut and re-connect ac power cord.

## 7. REPLACEABLE PARTS LIST:

This section lists and describes the parts located in the Model 8314 WLAN Simulator Subsystem (P/N 193-8132-X). The Replaceable Parts Lists (RPL) are intended for use in identifying, locating, and requisitioning assemblies and components for the Model 8314.

**7-1 UNDERSTANDING REFERENCE DESIGNATORS:** All assemblies and electrical parts are identified by standard reference designators (resistors R1, for example). Reference designators are used in parts lists and on parts identification drawings. The title of a parts list or drawing contains the reference designator or the assembly or subassembly to which it applies. The designators in the parts list, as a prefix, but omitted from the list to make it easier to locate a specific part. To complete a reference designator in a parts list, precede the designator for the specific part (DS1, for example) with the designator in the title (A6, for example) to form a complete reference designator for the part (in this case, A6DS1).

**7-2 ORDERING INFORMATION:** When ordering parts from Aeroflex / Weinschel, please include the following information:

- Aeroflex / Weinschel part number.
- Description of the component or part.
- Model and serial number of the instrument.
- Assembly number and assembly revision (if any) from the assembly (this information is on the component side of the PCB).

**7-3 DRAWING NUMBER:** The Aeroflex / Weinschel part number consists of a basic number with a dash number. The basic number should cross reference to a drawing number for most of the items. For those items that do not have a drawing number, the manufacturers part number is provided.

**7-4 REPLACEABLE PARTS LIST (RPL):** This RPL contains a breakdown of the instrument into its major assemblies and detailed parts. The following paragraphs describe the contents of each column of the RPL.

**7-4.1 REFERENCE DESIGNATOR:** This column contains reference designations arranged in alphanumerical sequence. The letters A thru Z have precedence, followed by numerals 0 thru 9. In addition to the reference designators that are listed, some mechanical parts are also listed. These items lack reference designators and are included because they are considered subject to wear and/or breakage, or because they are custom (non-standard) hardware or parts that might become lost or damaged. This column contains the word N/A for those items or parts not having a reference designator.

**7-4.2 DESCRIPTION:** This column contains the nomenclature located in the title block of the engineering drawing by the designing activity. The noun name is listed first, followed by modifiers and descriptive information to completely identify the part or assembly.

**7-4.3 PART NUMBER:** This column contains the Weinschel part number assigned to an assembly, sub-assembly, or detailed part. This also includes Weinschel numbers for specification control, source control, and altered items drawings.

**7-4.4 VENDOR PART NO.:** This column contains manufacturers part numbers for those parts Weinschel purchases, as off the shelf items and assigns Weinschel part numbers for internal control only. These parts may be ordered through the manufacturer or through Weinschel by the Weinschel part number.

**7-4.5 CAGE CODE:** This column provides the Commercial and Government Entity (CAGE) code on the same line as the applicable part number. Codes, names, and addresses of vendors with an assigned CAGE are listed in Cataloging Handbook H4-1 and H4-2. Vendors that have not been assigned CAGE codes by the government are identified by the word NONE in this column. The names and addresses of these vendors can be obtained from Weinschel. Part numbers that have no CAGE numbers listed are manufactured or altered by Weinschel.

**7-4.6 ASSEMBLY AND COMPONENT LOCATION:** The assembly/component location and schematic diagrams for the 8314 series models are located in rear of this manual by the drawing number. Drawing find numbers have also been included to help locate components or hardware.

## Model 8314-1, WLAN Simulator Subsystem Assembly Replaceable Parts List (P/N 193-8132-1):

Find No.	Part Number	Description	Quantity Used	Reference Designator	CAGE Code	Vendor Part Number
1	193-9701-3	ENCLOSURE, MODIFIED	1	NA		
2	193-9700	CHASSIS	1	NA		
3	193-9702	MOUNTING PLATE, ATTENUATOR	4	NA		
5	074-912	KIT, RACK MOUNTING W/O HANDLES 3.5 H	1	NA	24803	K2RMX-001A
7	193-9710-000	ASSY, PCB, CONTROLLER/ETHERNET	1	A1		
8	193-9711	ASSY, POWER SUPPLY	1	A2		
9	193-8097-000	ASSY, PCB, ATTEN DRIVER	1	A3		
10	193-9305-000	ASSY, PCB,LED STATUS	1	A4		
12	001-508	ATTEN PRGM PIN 60 dB, 2-6 GHz, 8 BIT	4	AT1 - AT4	56	A6P-48N-4MD
13	001-683-16	PWR DIV / COMBINER, 3-WAY 2-4 GHz SMA-F	1	A5	22424	803-2-3.000
14	3T-3	ATTEN FXD	2	AT5, AT9		
15	3T-8	ATTEN FXD	3	AT6 - AT8		
17	051-40	FUSE HOLDER, POWER INPUT, W/SWITCH	1	XF1	5245	PSOSXSS6B
18	052-1-1/2	FUSE 1/2 AMP	1	F1	75915	312-500
20	052-1-1	FUSE 1 AMP 250V	1	F1	75915	312001
21	063-165-1	ADAPTER, TYPE N FEMALE TO SMA MALE BULKHEAD DC TO 6GHz	4	NA	64671	5207-067
22	063-279	CONNECTOR, BNC, FEMALE BULKHEAD WITH GND TAB	2	NA	1VY65	CP-1094-AST
25	068-32-5/0	COAXIAL CABLE ASSY, SMA M/M, CONFORMABLE, DC TO 18 GHz	1	W7	93459	B068-32-5/0
26	068-32-4/0	COAXIAL CABLE ASSY, SMA M/M, CONFORMABLE, DC TO 18 GHz	1	W8		B068-32-4/0
27	068-32-6/0	COAXIAL CABLE ASSY, SMA M/M, CONFORMABLE, DC TO 18 GHz	1	NA		B068-32-6/0
28	068-32-8/0	COAXIAL CABLE ASSY, SMA M/M, CONFORMABLE, DC TO 18 GHz	1	NA		B068-32-8/0
29	193-9159	ASSY, CABLE, GND	1	W6		
32	193-9193	ASSY, CABLE, CONTROLLER TO FRONT PANEL DISPLAY	1	W5		
33	193-9704-1	ASSY, CABLE, RIBBON, 15 PIN FEMALE TO FEMALE	1	W1		
34	193-9704-2	ASSY, CABLE, RIBBON, 15 PIN FEMALE TO FEMALE	1	W2		
35	193-9704-3	ASSY, CABLE, RIBBON, 15 PIN FEMALE TO FEMALE	1	W3		
36	193-9704-4	ASSY, CABLE, RIBBON, 15 PIN FEMALE TO FEMALE	1	W4		
37	068-51	CORD PWR 3-CONDUCTOR DTCH 6.7FT 10A-125V NEMA5-15P/IEC320-C13	1	NA	16428	17506
38	074-170-5	CABLE TIE, #4-40 TIE DOWN	1	NA	56501	TY-33M
39	074-3-30	GROMMET, NYLON, FOR SHT THK .085 - .128 CATAPILLAR TYPE	1	NA	6915	MGS-3-01
40	062-184-5	CONN SCREW LOCK FEMALE	2	NA	71468	D20418-2
51	079-147-10	WIRE #22 BLACK TEFLON	1	NA	0	A079-147-10
53	079-147-9	WIRE #22 WHITE TEFLON	1	NA	0	A079-147-9
54	MS35649-244	NUT HEX #4	9	NA		
56	MS51957-19	SCR PAN HD 4-40 X 3/4 LG	2	NA		
57	MS51957-31	SCR PAN HD 6-32 X 5/8 LG	4	NA		
58	MS24693-C4	SCR FLAT HD 4-40 X 3/8 LG 100	6	NA		
59	MS24693-C10	SCR FLAT HD 4-40 X 1 LG 100	8	NA		

Model 8314-1, WLAN Simulator Subsystem Assembly Replaceable Parts List (P/N 193-8132-1):

Find No.	Part Number	Description	Quantity Used	Reference Designator	CAGE Code	Vendor Part Number
60	MS51957-15	SCR PAN HD 4-40 X 3/8 LG	18	NA		
61	MS15795-803	WASHER FLAT .125 ID, .250 OD	20	NA		
62	MS35338-135	WASHER LOCK #4	20	NA		
63	MS35338-136	WASHER LOCK #6	4	NA		
64	NAS1635-04LR-8	SCR, PAN HD #4-40 X 1/2 LG, SELF LOCK	1	NA		
65	074-889-8	LABEL, TAMPER RESIST WHT POLYESTER, .65 X .20	1	NA	BRADY	THT-14-423-10
66	090-354	* LABEL WARNING HIGH VOLTAGE	1	NA		
67	090-445	* LABEL, REFERENCE INSTR MANUAL	1	NA		
68	090-353	* LABEL GROUND	1	NA		
69	090-301	* LABEL STD, 1.5 X .75 IN	1	NA		
70	090-482	LABEL, POWER INPUT, 115/230V	1	NA		
71	090-285	* NAMEPLATE HIGH VOLTAGE	1	NA		
75	079-128-1	TUBING HEAT SHRINKABLE 1/8 DIA	0.25	NA	6090	RT-510-1/8
76	COML-55	LOCTITE 242, (BLUE) REMOVABLE THREADLOCK MEDIUM STRENGTH	0.001	NA		
78	193-8133	WIRING DIAGRAM, WLAN SIMULATOR MODEL 8314-1	0	NA		
79	IM477	O & S MANUAL, WLAN SIMULATOR MODEL 8314-1,-2	1	NA		
80	089-4037	ICD, WLAN SIMULATOR, MODEL 8314-1	0	NA		
81	ATP856	ACCEPTANCE TEST PROC WLAN SIMULATOR, MODEL 8314-1,-2	0	NA		

Refer to Aeroflex / Weinschel Drawing 193-8132-1 for parts location.

Model 8314-2, WLAN Simulator Subsystem Assembly Replaceable Parts List (P/N 193-8132-2):

Find No.	Part Number	Description	Quantity Used	Reference Designator	CAGE Code	Vendor Part Number
1	193-9701-4	ENCLOSURE, MODIFIED	1	NA		
2	193-9700	CHASSIS	1	NA		
3	193-9702	MOUNTING PLATE, ATTENUATOR	4	NA		
5	074-912	KIT, RACK MOUNTING W/O HANDLES 3.5 H	1	NA	24803	K2RMX-001A
7	193-9710-000	ASSY, PCB, CONTROLLER/ETHERNET	1	A1		
8	193-9711	ASSY, POWER SUPPLY	1	A2		
9	193-8097-000	ASSY, PCB, ATTEN DRIVER	1	A3		
10	193-9305-000	ASSY, PCB,LED STATUS	1	A4		
12	001-508	ATTEN PRGM PIN 60 dB, 2-6 GHz, 8 BIT	4	AT1 - AT4	56	A6P-48N-4MD
13	001-509	COMBINER/DIVIDER 3-WAY, 2-6GHz, SMA/F	1	A5	0HR85	PS3-12-451/1S
14	3T-3	ATTEN FXD	5	AT5 - AT9		
17	051-40	FUSE HOLDER, POWER INPUT, W/SWITCH	1	XF1	5245	PSOSXSS6B
18	052-1-1/2	FUSE 1/2 AMP	1	F1	75915	312-500
20	052-1-1	FUSE 1 AMP 250V	1	F1	75915	312001
21	063-165-1	ADAPTER, TYPE N FEMALE TO SMA MALE BULKHEAD DC TO 6GHz	4	NA	64671	5207-067
22	063-279	CONNECTOR, BNC, FEMALE BULKHEAD WITH GND TAB	2	NA	1VY65	CP-1094-AST
26	068-32-4/0	COAXIAL CABLE ASSY, SMA M/M, CONFORMABLE, DC TO 18 GHz	2	NA		B068-32-4/0
27	068-32-6/0	COAXIAL CABLE ASSY, SMA M/M, CONFORMABLE, DC TO 18 GHz	1	NA		B068-32-6/0
28	068-32-8/0	COAXIAL CABLE ASSY, SMA M/M, CONFORMABLE, DC TO 18 GHz	1	NA		B068-32-8/0
29	193-9159	ASSY, CABLE, GND	1	W6		
32	193-9193	ASSY, CABLE, CONTROLLER TO FRONT PANEL DISPLAY	1	W5		
33	193-9704-1	ASSY, CABLE, RIBBON, 15 PIN FEMALE TO FEMALE	1	W1		
34	193-9704-2	ASSY, CABLE, RIBBON, 15 PIN FEMALE TO FEMALE	1	W2		
35	193-9704-3	ASSY, CABLE, RIBBON, 15 PIN FEMALE TO FEMALE	1	W3		
36	193-9704-4	ASSY, CABLE, RIBBON, 15 PIN FEMALE TO FEMALE	1	W4		
37	068-51	CORD PWR 3-CONDUCTOR DTCH 6.7FT 10A-125V NEMA5-15P/IEC320-C13	1	NA	16428	17506
38	074-170-5	CABLE TIE, #4-40 TIE DOWN	1	NA	56501	TY-33M
39	074-3-30	GROMMET, NYLON, FOR SHT THK .085 - .128, CATAPILLAR TYPE	1	NA	6915	MGS-3-01
51	079-147-10	WIRE #22 BLACK TEFLON	1	NA	0	A079-147-10
53	079-147-9	WIRE #22 WHITE TEFLON	1	NA	0	A079-147-9
54	MS35649-244	NUT HEX #4	9	NA		
56	MS51957-19	SCR PAN HD 4-40 X 3/4 LG	2	NA		
57	MS51957-31	SCR PAN HD 6-32 X 5/8 LG	4	NA		
58	MS24693-C4	SCR FLAT HD 4-40 X 3/8 LG 100	6	NA		
59	MS24693-C10	SCR FLAT HD 4-40 X 1 LG 100	8	NA		
56	MS51957-19	SCR PAN HD 4-40 X 3/4 LG	2	NA		
57	MS51957-31	SCR PAN HD 6-32 X 5/8 LG	4	NA		
58	MS24693-C4	SCR FLAT HD 4-40 X 3/8 LG 100	6	NA		
59	MS24693-C10	SCR FLAT HD 4-40 X 1 LG 100	8	NA		

Model 8314-2, WLAN Simulator Subsystem Assembly Replaceable Parts List (P/N 193-8132-2):

Find No.	Part Number	Description	Quantity Used	Reference Designator	CAGE Code	Vendor Part Number
60	MS51957-15	SCR PAN HD 4-40 X 3/8 LG	18	NA		
61	MS15795-803	WASHER FLAT .125 ID, .250 OD	20	NA		
62	MS35338-135	WASHER LOCK #4	20	NA		
63	MS35338-136	WASHER LOCK #6	4	NA		
64	NAS1635-04LR-8	SCR, PAN HD #4-40 X 1/2 LG, SELF LOCK	1	NA		
65	074-889-8	LABEL, TAMPER RESIST WHT POLYESTER .65 X .20	1	NA	BRADY	THT-14-423-10
66	090-354	* LABEL WARNING, HIGH VOLTAGE	1	NA		
67	090-445	* LABEL, REFERENCE INSTR MANUAL	1	NA		
68	090-353	* LABEL GROUND	1	NA		
69	090-301	* LABEL STD 1.5 X .75 IN	1	NA		
70	090-482	LABEL, POWER INPUT, 115/230V	1	NA		
71	090-285	* NAMEPLATE HIGH VOLTAGE	1	NA		
75	079-128-1	TUBING HEAT SHRINKABLE 1/8 DIA	0.25	NA	6090	RT-510-1/8
76	COML-55	LOCTITE 242, (BLUE) REMOVABLE THREADLOCK MEDIUM STRENGTH	0.001	NA		
78	193-8134	WIRING DIAGRAM WLAN SIMULATOR MODEL 8314-2	0	NA		
79	IM477	O & S MANUAL, WLAN SIMULATOR MODEL 8314-1,-2	1	NA		
80	089-4038	ICD, WLAN SIMULATOR MODEL 8314-2	0	NA		
81	ATP856	ACCEPTANCE TEST PROC WLAN SIMULATOR, MODEL 8314-1,-2	0	NA		

Refer to Aeroflex / Weinschel Drawing 193-8132-2 for parts location.

## 9. CONTACTING AEROFLEX / WEINSCHEL:

In the event of a malfunction, contact Aeroflex / Weinschel, Inc. An apparent malfunction of an instrument or component may be diagnosed over the phone by first contacting the Customer Service Department at Aeroflex / Weinschel, Inc. DO NOT send the instrument or component back to the factory without prior authorization. When it is necessary to return an item, state the symptoms, catalog and type number of the instrument or component, and date of original purchase. Also write the Company name and your name and phone number on a card and tape the card to the item returned. Page provides further information regarding preparation of a unit for reshipment. Contact Aeroflex / Weinschel Customer Service Department as follows:

**Via mail:** Aeroflex / Weinschel, Inc.  
5305 Spectrum Drive  
Frederick, MD 21703-7362  
U.S.A.

**Via Telefax:** 301-846-9116

**Via Phone:** Call TOLL FREE 800-638-2048  
Toll call # 301-846-9222

**Via Website:** [www.aeroflex-weinschel.com](http://www.aeroflex-weinschel.com)

**Via e-mail:** [weinschel-sales@aeroflex.com](mailto:weinschel-sales@aeroflex.com)

## 10. AEROFLEX / WEINSCHEL WARRANTY:

**PRODUCTS** – Aeroflex / Weinschel warrants each product it manufactures to be free from defects in material and workmanship under normal use and service anywhere in the world. Aeroflex / Weinschel's only obligation under this Warranty is to repair or replace, at its plant, any product or part thereof that is returned with transportation charges prepaid to Aeroflex / Weinschel by the original purchaser within ONE YEAR from the date of shipment.

The foregoing Warranty does not apply Aeroflex / Weinschel's sole opinion to products that have been subject to improper or inadequate maintenance, unauthorized modifications, misuse, or operation outside the environmental specifications for the product.

**SOFTWARE PRODUCTS-** Aeroflex / Weinschel software products are supplied without representation or Warranty of any kind. Aeroflex / Weinschel, therefore, assumes no responsibility and will not accept liability (consequential or otherwise) arising from the use of program materials, disk, or tape.

The Warranty period is controlled by the Warranty document furnished with each product and begins on the date of shipment. All Warranty returns must be authorized by Aeroflex / Weinschel prior to their return.

Aeroflex / Weinschel's Quality System Certified to:



Certificate No. 289I

© 2008 Aeroflex / Weinschel, Inc.

DWG. NO.		REV. 1		1	
REVISIONS					
ZONE	REV.	DESCRIPTION	DATE	APPROVED	
A		ERN 08-027	M.T.	2/08	

- NOTES:
- POWER CORD, ITEM 37, SUPPLIED BUT NOT SHOWN.
  - PERMANENTLY MARK ALL INFORMATION LOCATED ON MAC ADDRESS LABEL (ATTACHED TO ITEM 7) ON NEW LABEL, ITEM 65.
  - AFTER ASSY, CONFIGURE AND TEST PER ATP856
  - COMPLETELY SLEEVE SIGNAL CONNECTION (WHITE WIRE), USING ITEM 75, 2 PLCS.

D  
C  
B  
A

D  
C  
B  
A

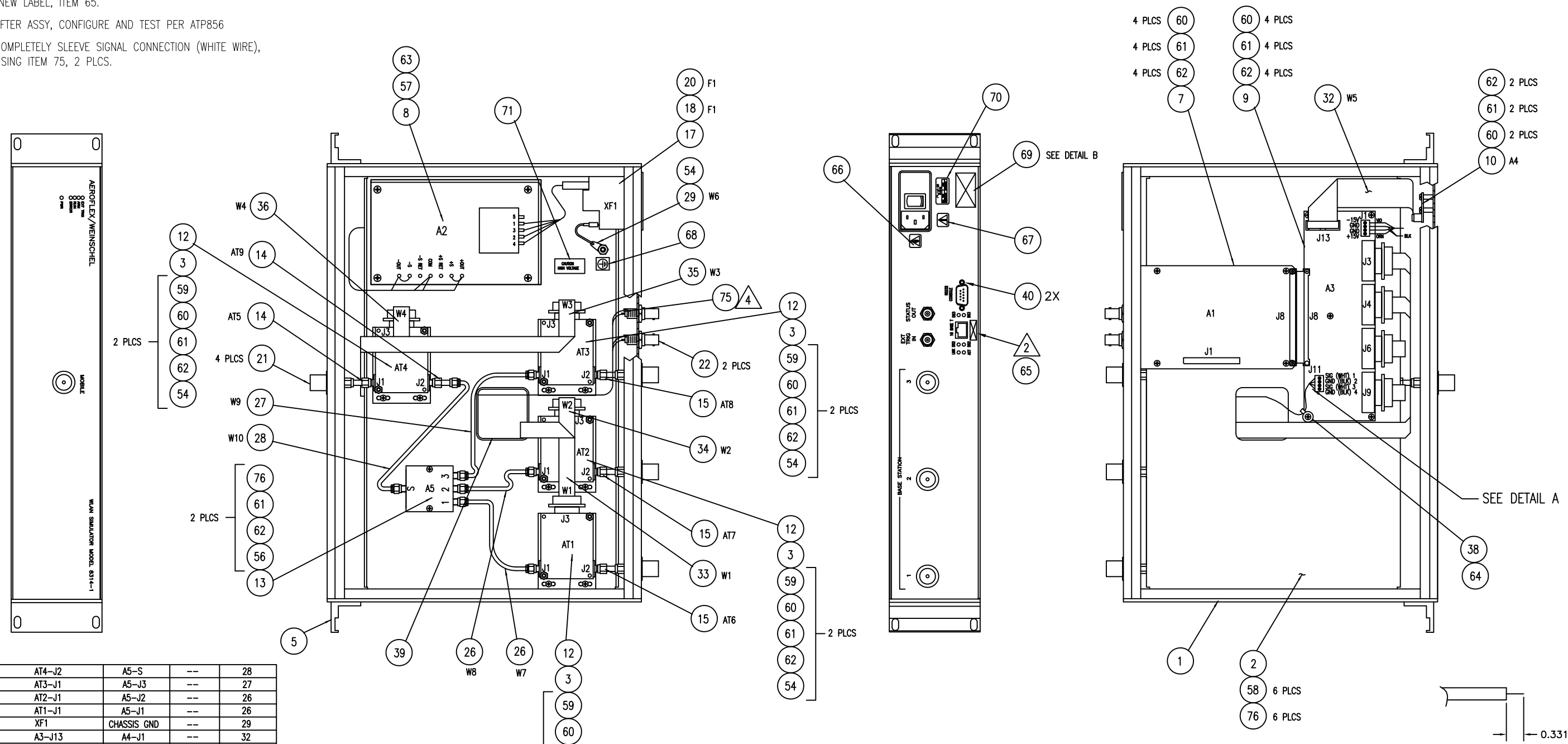

W10	AT4-J2	A5-S	--	28
W9	AT3-J1	A5-J3	--	27
W8	AT2-J1	A5-J2	--	26
W7	AT1-J1	A5-J1	--	26
W6	XF1	CHASSIS GND	--	29
W5	A3-J13	A4-J1	--	32
W4	AT4-J3	A3-J9	--	36
W3	AT3-J3	A3-J6	--	35
W2	AT2-J3	A3-J4	--	34
W1	AT1-J3	A3-J3	--	33
	STATUS OUT GND	A3-J11-4	BLK	51
	STATUS OUT (CENTER)	A3-J11-3	WHT	53
	EXT TRIG GND	A3-J11-2	BLK	51
	EXT TRIG IN (CENTER)	A3-J11-1	WHT	53
	A2 -OUT	A3-J1 -15	VIO	8
	A2 COM	A3-J1 GND	BLK	8
	A2 COM	A3-J1 GND	BLK	8
	A2 +OUT	A3-J1 +15	ORN	8
	A2-P1	XF1		8
REF DES	FROM	TO	COLOR	ITEM

TWISTED, SEE DETAIL A  
TWISTED, SEE DETAIL A  
TWISTED  
TWISTED

Aeroflex/Weinschel  
ONE CODE BRAND MADE IN THE USA  
MODEL: 8314-1 SERNO: XXXX  
FREQ: 2 TO 4 GHz  
CHAN: 3  
ATTEN: 63.75dB/25dB STEPS

DETAIL B  
ENLARGED

DETAIL A  
ENLARGED

FOR PARTS LIST SEE PL193-8132-1

QTY	REQD	FROM NO.	PART OR IDENTIFYING NO.	NOMENCLATURE OR DESCRIPTION	MATERIAL SPECIFICATION	ZONE	ITEM NO.
PARTS LIST							
UNLESS OTHERWISE SPECIFIED DIMENSIONS ARE IN INCHES TOLERANCES ARE FRACTIONS DECIMALS ANGLES				CONTRACT NO.			
$\frac{1}{64}$ $\frac{1}{32}$ $\frac{1}{16}$ $\frac{3}{32}$ $\frac{1}{8}$ $\frac{3}{16}$ $\frac{1}{4}$ $\frac{3}{8}$ $\frac{1}{2}$				APPROVALS M. TYSON 2/08 A. HOPKINS 3/08 B. KNILL 3/08			
MATERIAL				DRAWN			
FINISH				CHECKED			
NEXT ASSY				ISSUED			
APPLICATION				SCALE 1/2			
DO NOT SCALE DRAWING				ASSY, WLAN SIMULATOR MODEL 8314-1 SIZE D FSCM NO. 93459 DWG. NO. 193-8132-1 REV. A SHEET 1 OF 1			

PROPRIETARY NOTICE  
THIS DOCUMENT IS COMMERCIAL CONFIDENTIAL AND THE INFORMATION CONTAINED THEREIN MAY NOT BE DISSEMINATED, NOR IS REPRODUCTION PERMITTED EXCEPT BY WRITTEN AUTHORIZATION.

REVISIONS				
ZONE	REV.	DESCRIPTION	DATE	APPROVED
A	ERN 08-027		MT 2/08	

- NOTES:
- POWER CORD, ITEM 37, SUPPLIED BUT NOT SHOWN.
  - PERMANENTLY MARK ALL INFORMATION LOCATED ON MAC ADDRESS LABEL (ATTACHED TO ITEM 7) ON NEW LABEL, ITEM 65.
  - AFTER ASSY, CONFIGURE AND TEST PER ATP856
  - COMPLETELY SLEEVE SIGNAL CONNECTION (WHITE WIRE), USING ITEM 75, 2 PLCS.

D  
C  
B  
A

D  
C  
B  
A

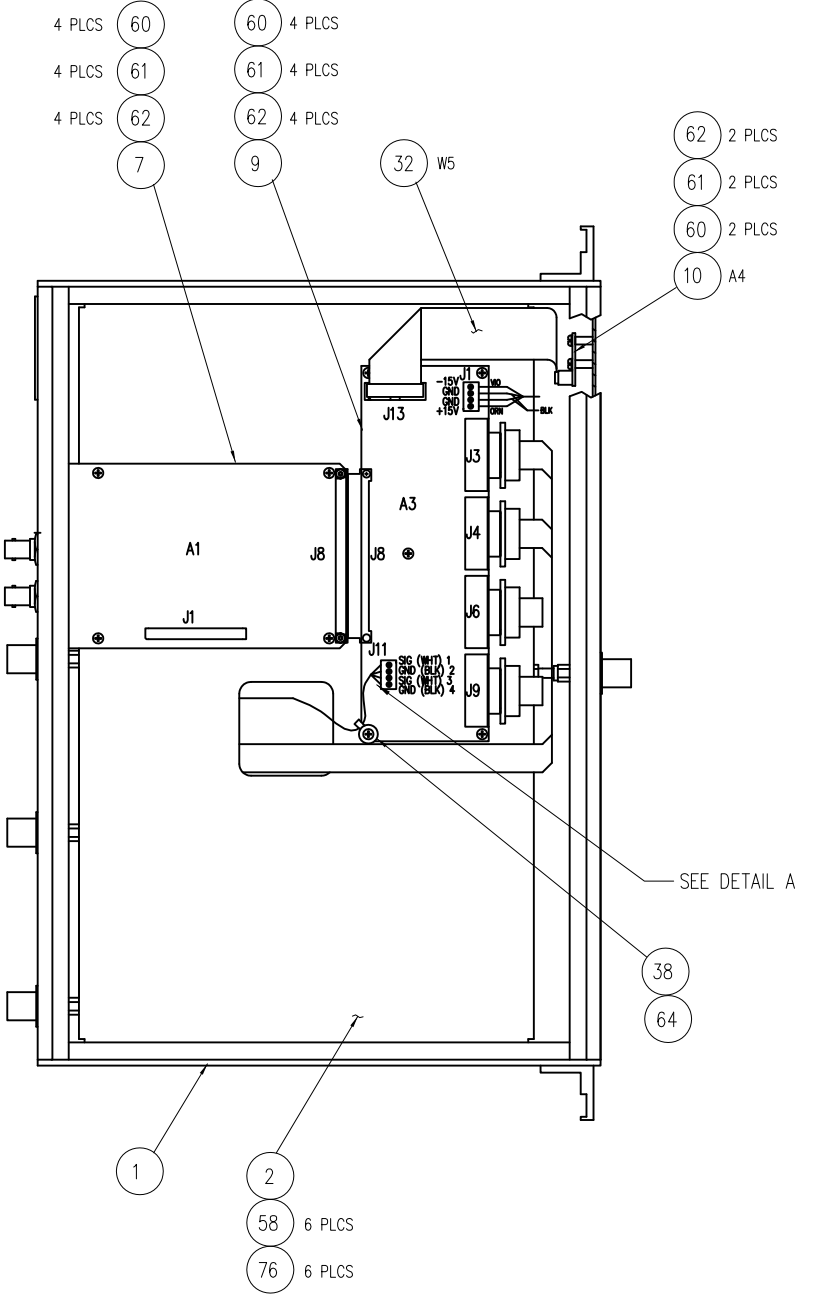
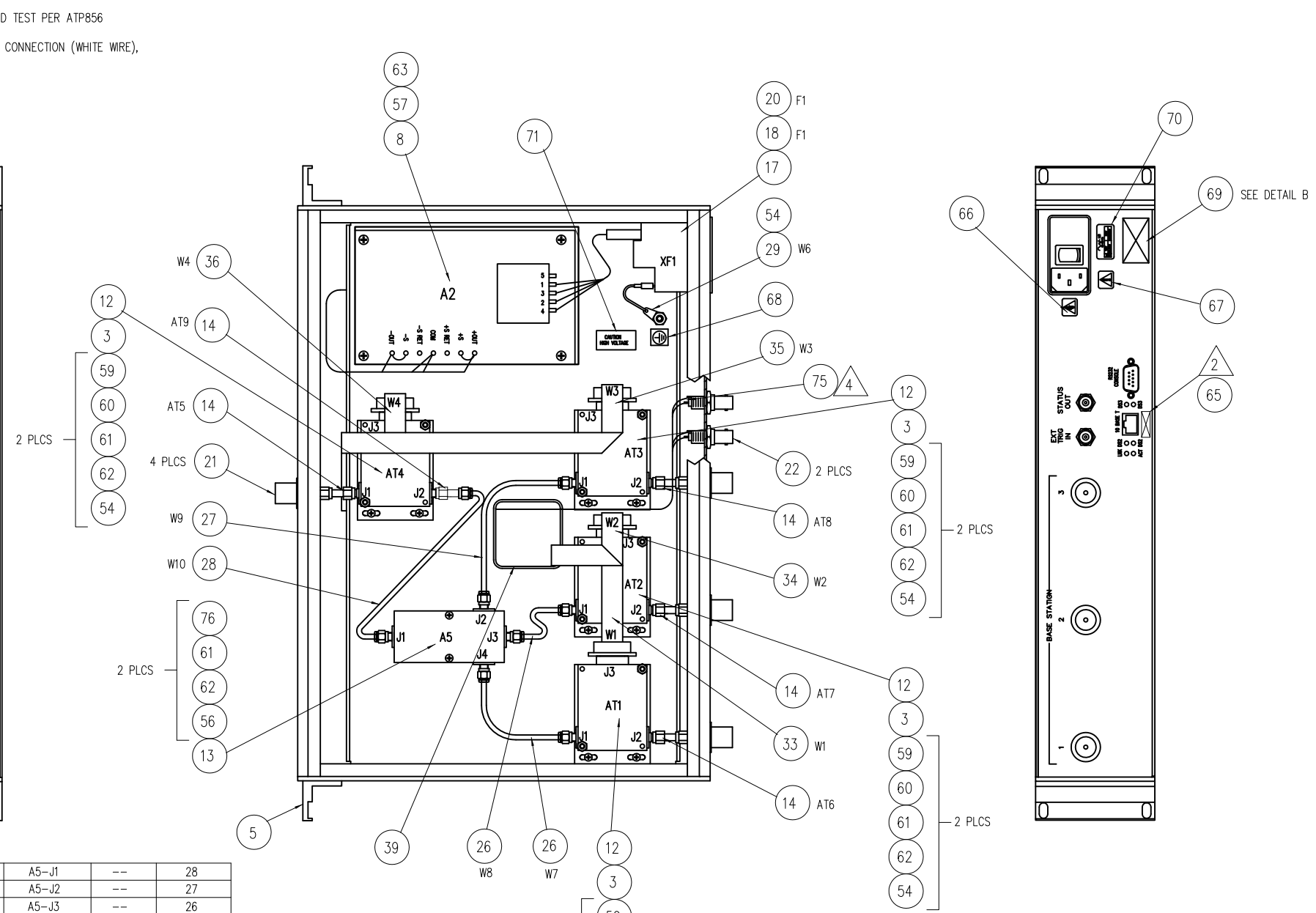
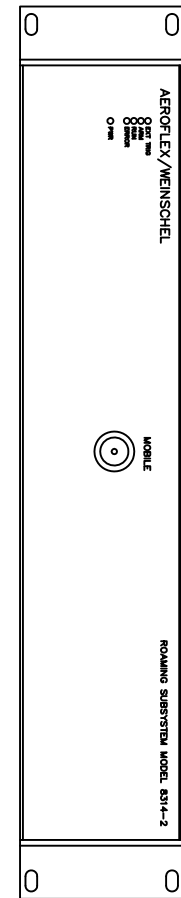

W10	AT4-J2	A5-J1	--	28
W9	AT3-J1	A5-J2	--	27
W8	AT2-J1	A5-J3	--	26
W7	AT1-J1	A5-J4	--	26
W6	XF1	CHASSIS GND	--	29
W5	A3-J13	A4-J1	--	32
W4	AT4-J3	A3-J9	--	36
W3	AT3-J3	A3-J6	--	35
W2	AT2-J3	A3-J4	--	34
W1	AT1-J3	A3-J3	--	33
	STATUS OUT GND	A3-J11-4	BLK	51
	STATUS OUT (CENTER)	A3-J11-3	WHT	53
	EXT TRIG GND	A3-J11-2	BLK	51
	EXT TRIG IN (CENTER)	A3-J11-1	WHT	53
	A2 -OUT	A3-J1 -15	VIO	8
	A2 COM	A3-J1 GND	BLK	8
	A2 COM	A3-J1 GND	BLK	8
	A2 +OUT	A3-J1 +15	ORN	8
	A2-P1	XF1		8
REF DES	FROM	TO	COLOR	ITEM

TWISTED, SEE DETAIL A  
TWISTED, SEE DETAIL A  
TWISTED  
TWISTED



PROPRIETARY NOTICE  
THIS DOCUMENT IS COMMERCIAL CONFIDENTIAL AND THE INFORMATION CONTAINED THEREIN MAY NOT BE DISSEMINATED, NOR IS REPRODUCTION PERMITTED EXCEPT BY WRITTEN AUTHORIZATION.

QTY REQD	FROM NO.	PART OR IDENTIFYING NO.	NOMENCLATURE OR DESCRIPTION	MATERIAL SPECIFICATION	ZONE	ITEM NO.
PARTS LIST						
UNLESS OTHERWISE SPECIFIED DIMENSIONS ARE IN INCHES TOLERANCES ARE FRACTIONS DECIMALS ANGLES * 1/64 * .001 * 1/2						
APPROVALS		DATE		ASSY, ROAMING SYSTEM MODEL 8314-2		
DRAWN M. TYSON		2/08		SIZE D FSCM NO. 93459 DWG. NO. 193-8132-2 REV. A		
CHECKED A. HOPKINS		3/08		SCALE 1/2 SHEET 1 OF 1		
ENGR. B. KNILL		3/08		APPLICATION USED ON		
ISSUED		DO NOT SCALE DRAWING		NEXT ASSY		

REVISIONS				
ZONE	REV.	DESCRIPTION	DATE	APPROVED
A	ERN 08-027		M.T.	2/08

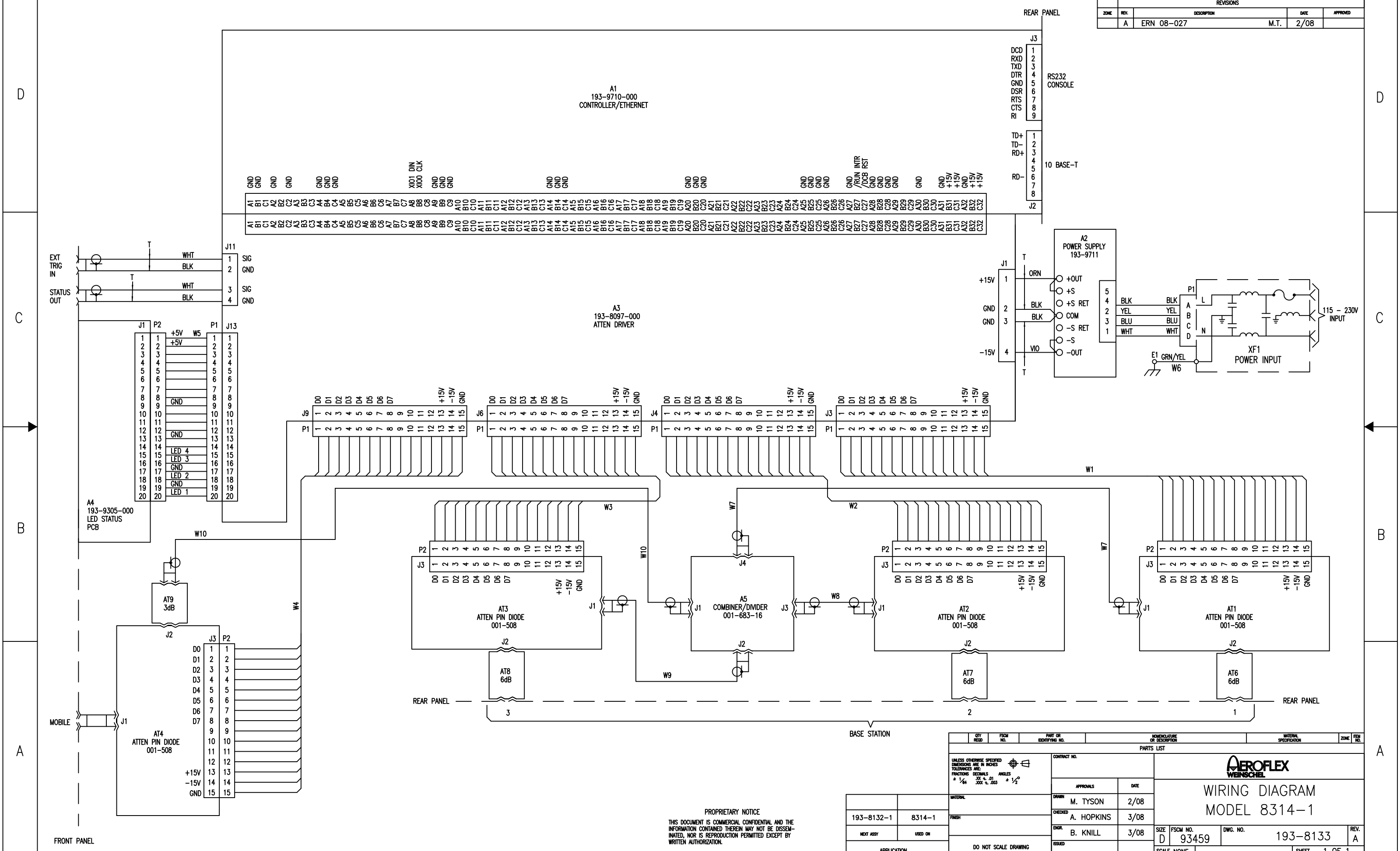

PROPRIETARY NOTICE  
 THIS DOCUMENT IS COMMERCIAL CONFIDENTIAL AND THE INFORMATION CONTAINED THEREIN MAY NOT BE DISSEMINATED, NOR IS REPRODUCTION PERMITTED EXCEPT BY WRITTEN AUTHORIZATION.

QTY	REQD	FROM	NO.	PART OR IDENTIFYING NO.	NOMENCLATURE OR DESCRIPTION	MATERIAL SPECIFICATION	ZONE	ITEM NO.
PARTS LIST								
UNLESS OTHERWISE SPECIFIED DIMENSIONS ARE IN INCHES TOLERANCES ARE FRACTIONS DECIMALS ANGLES				CONTRACT NO.				
$\frac{1}{16}$ $\frac{1}{32}$ $\frac{1}{64}$ $\frac{1}{128}$ $\frac{1}{256}$				APPROVALS DRAWN: M. TYSON CHECKED: A. HOPKINS ENGR: B. KNILL ISSUED:				
DATE: 2/08				DATE: 3/08				
DATE: 3/08				DATE: 3/08				
SIZE: D		FSCM NO.: 93459		DWG. NO.: 193-8133		REV. A		
SCALE: NONE		SHEET: 1 OF 1						

REVISIONS				
ZONE	REV.	DESCRIPTION	DATE	APPROVED
A	ERN 08-027		MT 2/08	

D

D

C

C

B

B

A

A

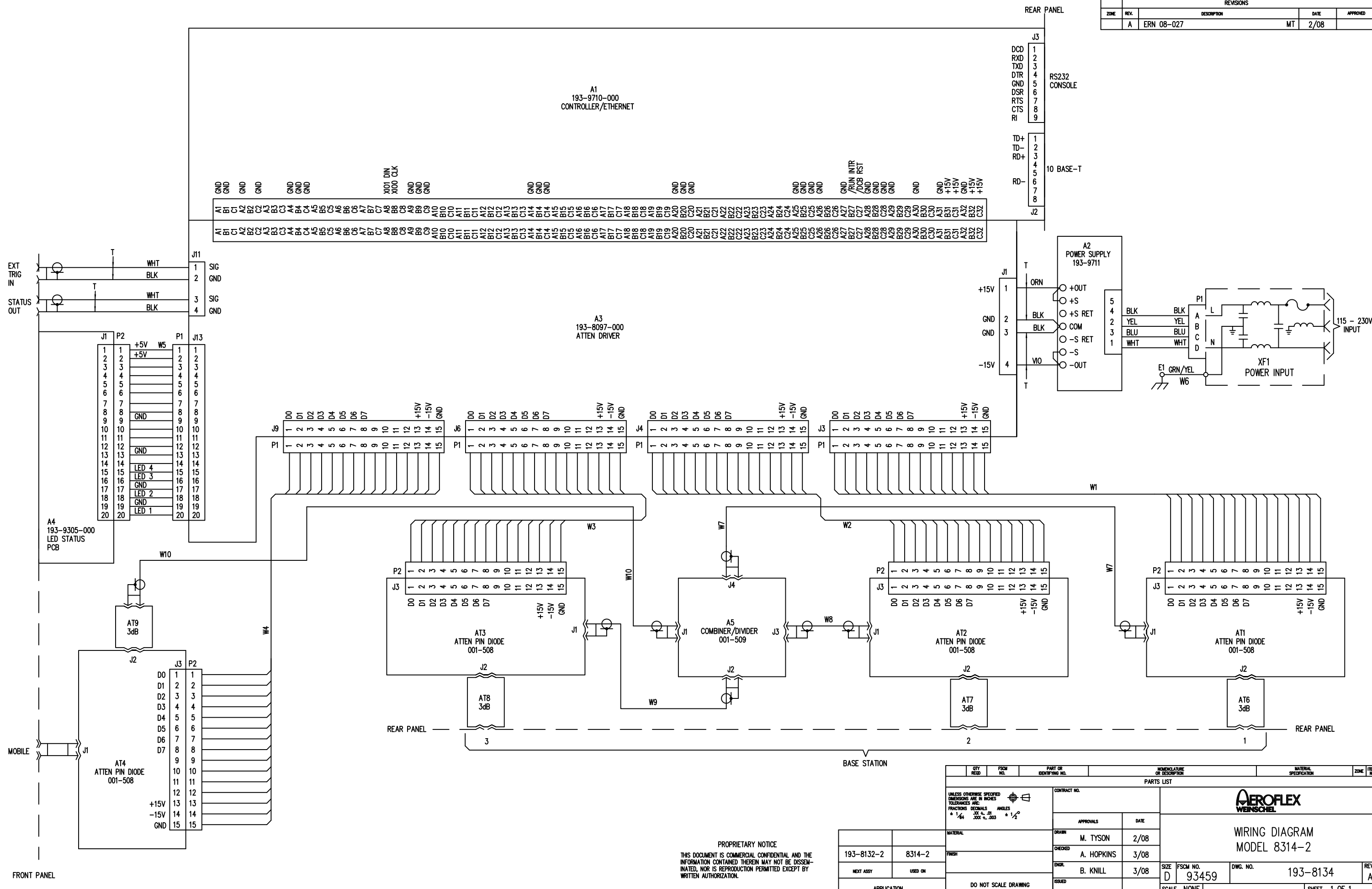

PROPRIETARY NOTICE  
 THIS DOCUMENT IS COMMERCIAL CONFIDENTIAL AND THE INFORMATION CONTAINED THEREIN MAY NOT BE DISSEMINATED, NOR IS REPRODUCTION PERMITTED EXCEPT BY WRITTEN AUTHORIZATION.

QTY	REQD	FORM NO.	PART OR IDENTIFYING NO.	NOMENCLATURE OR DESCRIPTION	MATERIAL SPECIFICATION	ZONE	ITEM NO.
PARTS LIST							
UNLESS OTHERWISE SPECIFIED DIMENSIONS ARE IN INCHES TOLERANCES ARE FRACTIONS DECIMALS ANGLES				CONTRACT NO.			
1/16 ± .015 3/32 ± .010 1/8 ± .010 1/4 ± .015 3/8 ± .020 1/2 ± .030 3/4 ± .040 1 ± .060 2 ± .100				APPROVALS			
MATERIAL				DRAWN M. TYSON 2/08			
FINISH				CHECKED A. HOPKINS 3/08			
NEXT ASSY				ENGR. B. KNILL 3/08			
USED ON				ISSUED			
APPLICATION				DO NOT SCALE DRAWING			
SIZE D		FSCM NO. 93459		DWG. NO. 193-8134		REV. A	
SCALE NONE		SHEET 1 OF 1					



WIRING DIAGRAM  
 MODEL 8314-2

SH	1	REV.		REVISIONS	
ZONE	REV.	DESCRIPTION	DATE	APPROVED	
A		ERN 08-027			

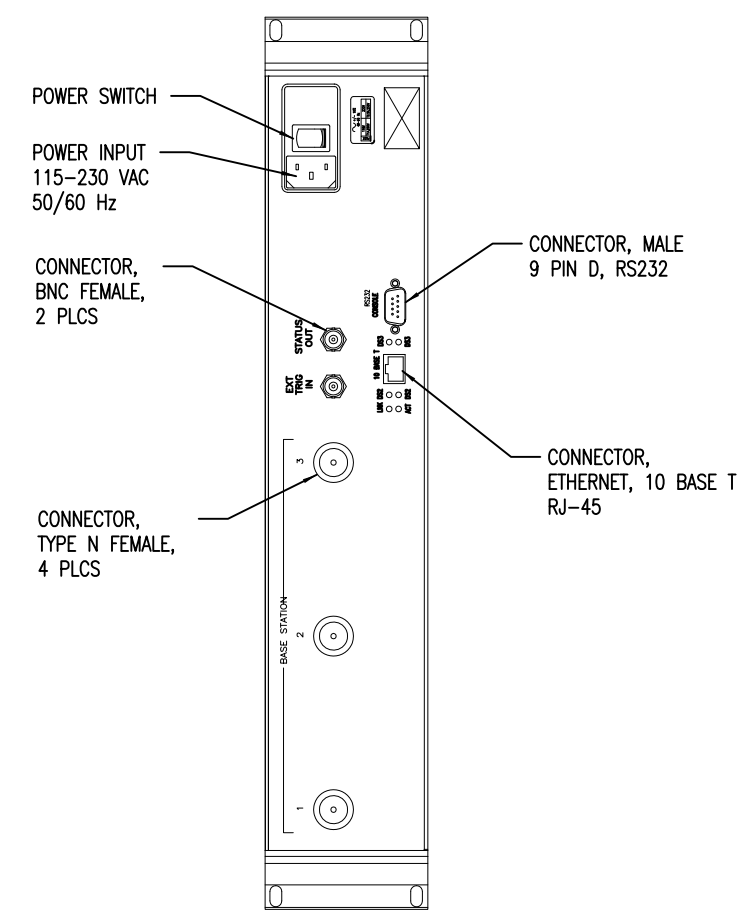
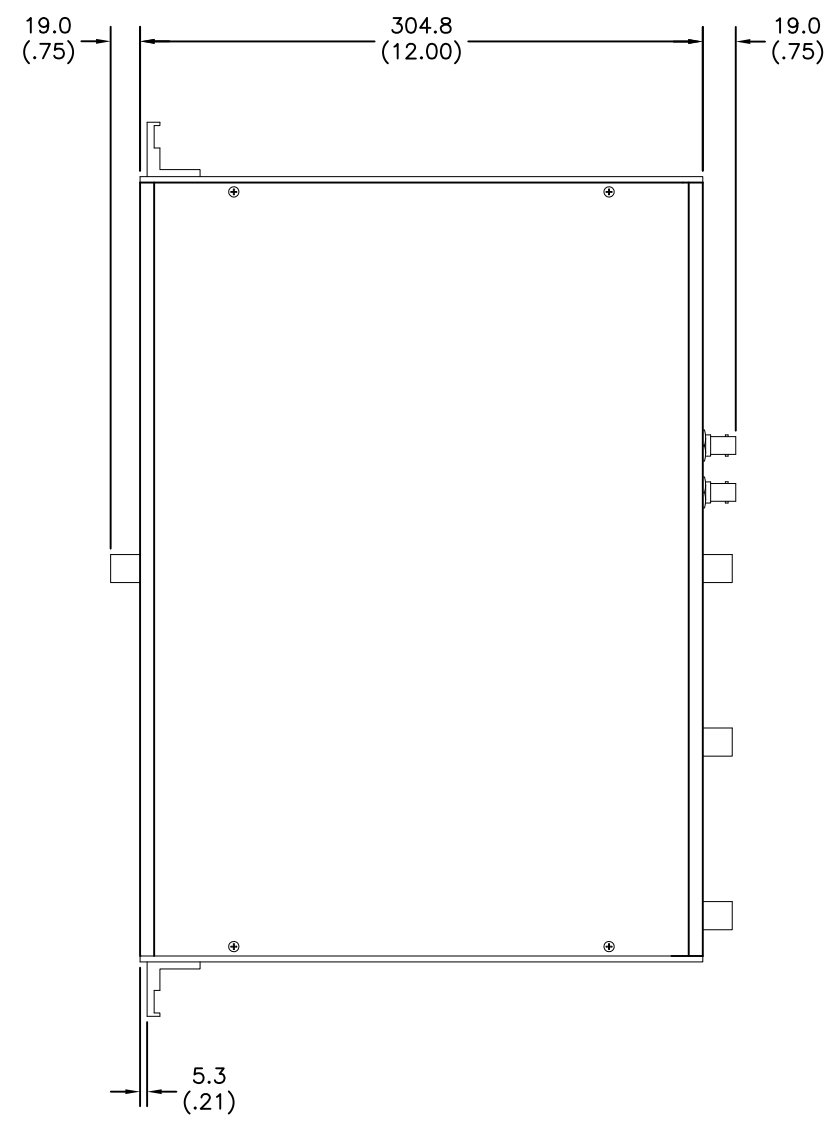
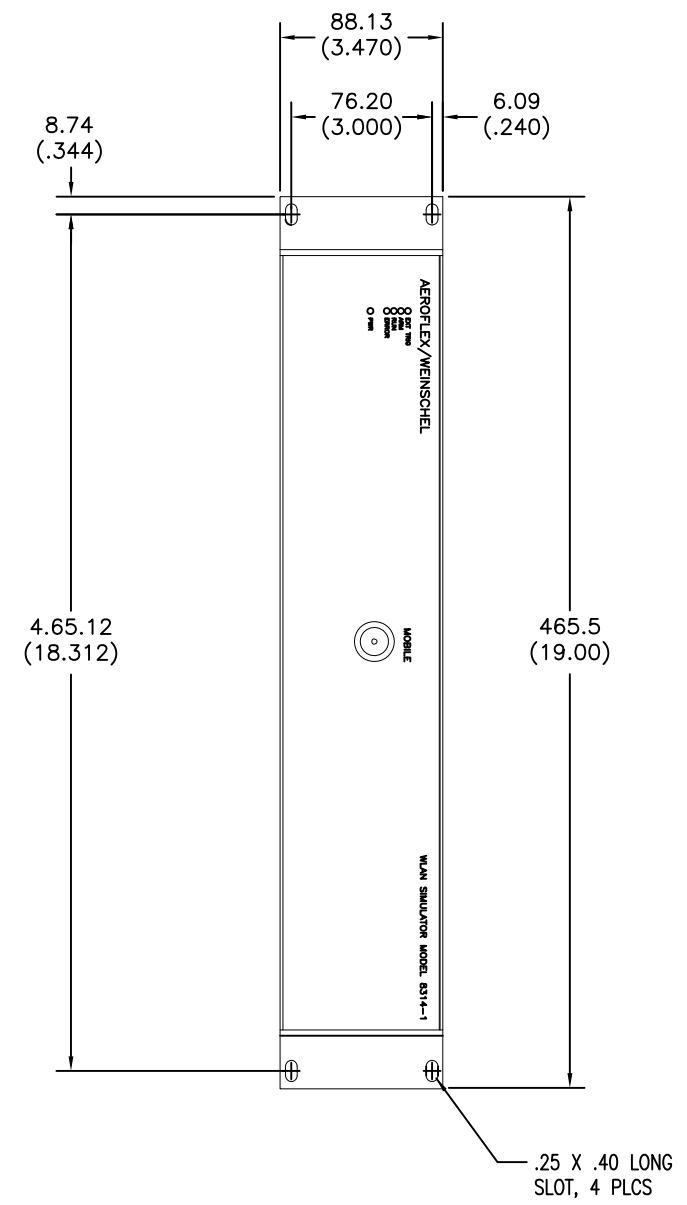

NOTES:  
1. ALL DIMENSIONS GIVEN IN MM (INCHES)

**SPECIFICATIONS**  
 FREQUENCY RANGE: 2 TO 4 GHz  
 IMPEDANCE: 50 OHM  
 ATTENUATION RANGE: 63.75 dB / .25 dB STEPS PER CHANNEL  
 INCREMENTAL ATTENUATION ACCURACY: +/- 5% OF SELECTED VALUE  
 INSERTION LOSS: 27 dB  
 RF POWER: +25 dBm  
 VSWR: 1.75:1 TARGET  
 PORT TO PORT ISOLATION >40dB

**PROPRIETARY NOTICE**  
 THIS DOCUMENT IS COMMERCIAL CONFIDENTIAL AND THE INFORMATION CONTAINED THEREIN MAY NOT BE DISSEMINATED, NOR IS REPRODUCTION PERMITTED EXCEPT BY WRITTEN AUTHORIZATION.

INTERFACE CONTROL DRAWING

QTY REQD	FROM NO.	PART OR IDENTIFYING NO.	NOMENCLATURE OR DESCRIPTION	MATERIAL SPECIFICATION	ZONE	ITEM NO.
PARTS LIST						
UNLESS OTHERWISE SPECIFIED DIMENSIONS ARE IN INCHES TOLERANCES ARE FRACTIONS DECIMALS ANGLES		CONTRACT NO.		 ICD, WLAN SIMULATOR MODEL 8314-1		
$\pm \frac{1}{64}$ $\pm .01$ $\pm \frac{1}{2}^\circ$ $\pm .005$ $\pm .003$		APPROVALS	DATE			
MATERIAL	FINISH	M. TYSON	1/08			
NEXT ASSY    USED ON		CHECKED	3/08			
APPLICATION		DO NOT SCALE DRAWING	ENGR. KNILL	3/08	SIZE D	FSCM NO. 93459
			ISSUED		DWG. NO. 089-4037	REV. A
					SCALE 1/2	SHEET 1 OF 1

SH	1	REV.		REVISIONS	
ZONE	REV.	DESCRIPTION	DATE	APPROVED	
A		ERN 08-027			

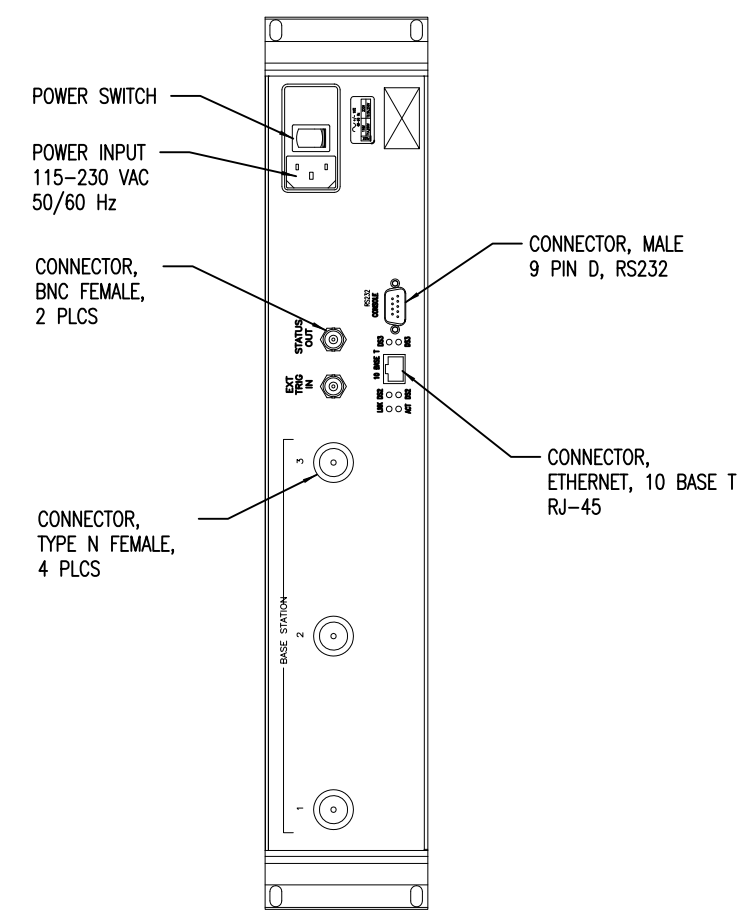
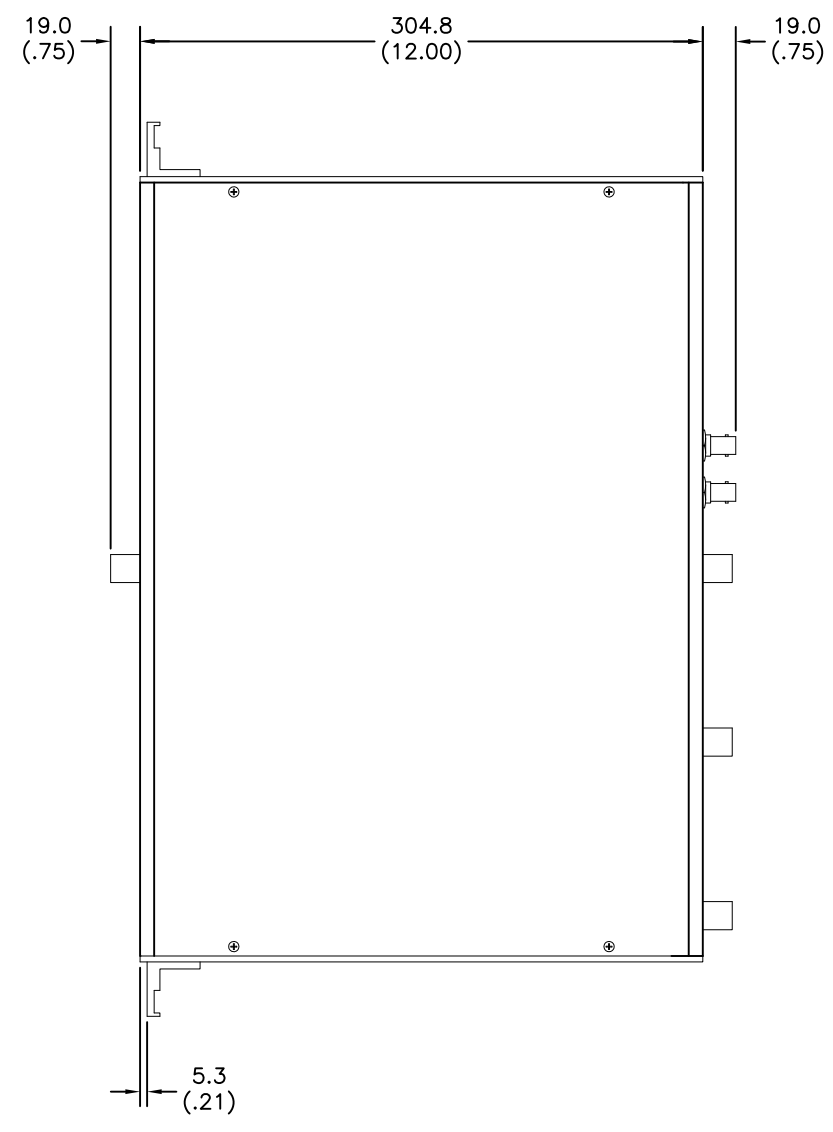
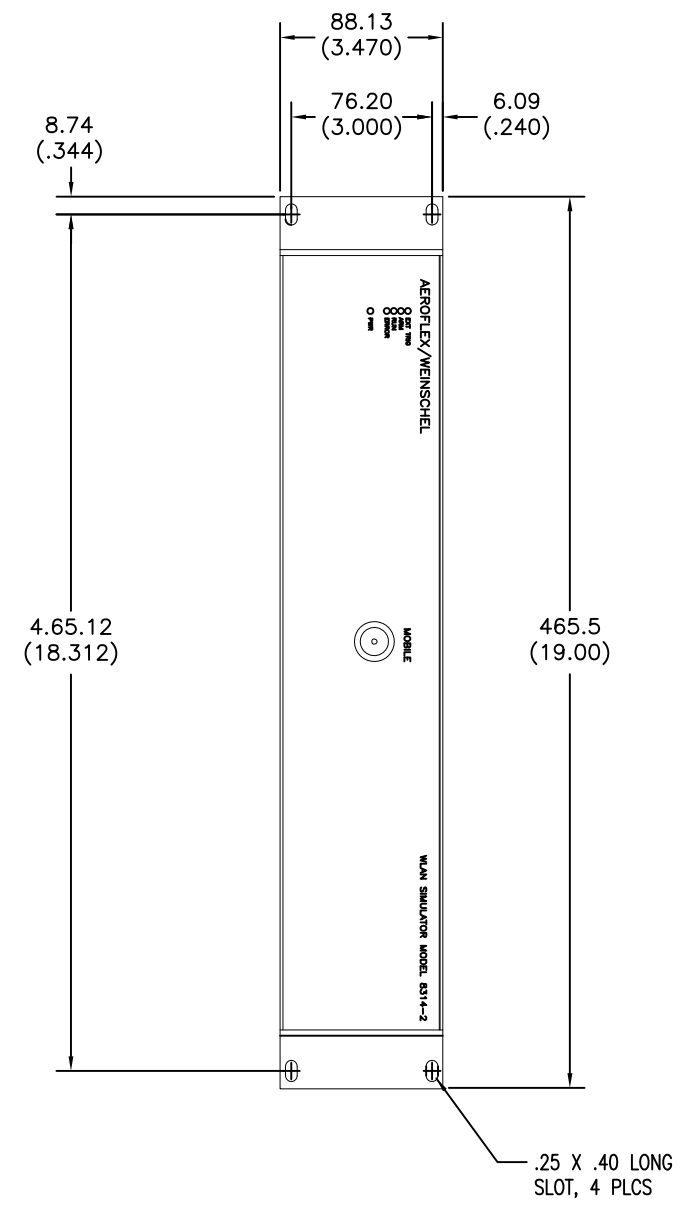

NOTES:  
1. ALL DIMENSIONS GIVEN IN MM (INCHES)

**SPECIFICATIONS**  
 FREQUENCY RANGE: 2 TO 6 GHz  
 IMPEDANCE: 50 OHM  
 ATTENUATION RANGE: 63.75 dB / .25 dB STEPS PER CHANNEL  
 INCREMENTAL ATTENUATION ACCURACY: +/- 5% OF SELECTED VALUE  
 INSERTION LOSS: 21 dB  
 RF POWER: +22 dBm  
 VSWR: 1.60:1 TARGET

**PROPRIETARY NOTICE**  
 THIS DOCUMENT IS COMMERCIAL CONFIDENTIAL AND THE INFORMATION CONTAINED THEREIN MAY NOT BE DISSEMINATED, NOR IS REPRODUCTION PERMITTED EXCEPT BY WRITTEN AUTHORIZATION.

INTERFACE CONTROL DRAWING

QTY	REQD	FROM NO.	PART OR IDENTIFYING NO.	NOMENCLATURE OR DESCRIPTION	MATERIAL SPECIFICATION	ZONE	ITEM NO.																										
PARTS LIST																																	
UNLESS OTHERWISE SPECIFIED DIMENSIONS ARE IN INCHES TOLERANCES ARE FRACTIONS DECIMALS ANGLES																																	
<table border="1"> <tr> <td>CONTRACT NO.</td> <td></td> </tr> <tr> <td>APPROVALS</td> <td>DATE</td> </tr> <tr> <td>M. TYSON</td> <td>1/08</td> </tr> <tr> <td>CHECKED</td> <td>HOPKINS</td> </tr> <tr> <td>3/08</td> <td></td> </tr> <tr> <td>ENGR.</td> <td>KNILL</td> </tr> <tr> <td>3/08</td> <td></td> </tr> <tr> <td>ISSUED</td> <td></td> </tr> </table>				CONTRACT NO.		APPROVALS	DATE	M. TYSON	1/08	CHECKED	HOPKINS	3/08		ENGR.	KNILL	3/08		ISSUED		<table border="1"> <tr> <td colspan="2">ICD, WLAN SIMULATOR MODEL 8314-2</td> </tr> <tr> <td>SIZE</td> <td>FSCM NO.</td> </tr> <tr> <td>D</td> <td>93459</td> </tr> <tr> <td>DWG. NO.</td> <td>089-4038</td> </tr> <tr> <td>REV.</td> <td>A</td> </tr> </table>				ICD, WLAN SIMULATOR MODEL 8314-2		SIZE	FSCM NO.	D	93459	DWG. NO.	089-4038	REV.	A
CONTRACT NO.																																	
APPROVALS	DATE																																
M. TYSON	1/08																																
CHECKED	HOPKINS																																
3/08																																	
ENGR.	KNILL																																
3/08																																	
ISSUED																																	
ICD, WLAN SIMULATOR MODEL 8314-2																																	
SIZE	FSCM NO.																																
D	93459																																
DWG. NO.	089-4038																																
REV.	A																																
APPLICATION		DO NOT SCALE DRAWING		SCALE 1/2		SHEET 1 OF 1																											

# APPENDIX A

## CARE AND HANDLING OF MICROWAVE COAXIAL CABLE ASSEMBLIES

### **A-1 CARE AND HANDLING OF ASSEMBLIES.**

To ensure accurate measurements and optimal performance of Weinschel products, the microwave coaxial cable assemblies used in system and test setups must be properly used and maintained. Proper connections, routine inspection of all cables, and cleaning of the connectors are extremely important procedures which can prolong the longevity and accuracy of equipment.

### **A-2 CABLE INSPECTION.**

Routinely check external cables for signs of cracked insulation, dents, twists, flattening, signs of jacket abrasion, or other signs of abuse. Wrinkles in the jacket indicate that the minimum bend radius has been exceeded. Most often, this occurs near the marker tubes and connectors.

Also inspect the connector interfaces for the following:

- Bent pins (male).
- Bent or missing tines (female).
- Worn or chipped plating.
- Damaged or displaced dielectric inserts.
- Thread damage.
- Folded or mushroomed outer interface rims.
- Mushroomed pin shoulders (male) or tine ends (female).
- Score lines on pins and outer interface rims visible to the unaided eye.
- Recessed or protruding pins.

It is advisable to clean the connectors prior to inspection to make subtle damage more apparent. If any of the above is noted, replace the assembly before its further use results in equipment damage. Also inspect the mating connectors for similar damage.

Inspect the connector interface for signs of debris. Debris may be in the form of:

- Plating chips or other metal particles.
- Dust or dirt.
- Oily films.
- Other miscellaneous foreign particles.

If signs of debris are present, clean the connector interface as directed in Paragraph A-6.

### **A-3 MAKING INITIAL CONNECTIONS.**

Exercise caution when mating cables. Poor connections lead to poor system performance. They can also damage not only the cable assembly, but more significantly, front or rear panel connectors on the equipment itself which may be more difficult to repair.

**A-3.1 ALIGNING CONNECTORS.** Align the center lines of two connectors before actual mating. Male retaining nuts contain a small amount of necessary play which may make it possible to mate the threads without the pins being properly aligned. Pin misalignment can damage pins and dielectric inserts.

**A-3.2 MATING CONNECTORS.** Gently mate the connectors by hand, taking care not to force the coupling nut at the slightest resistance. It is often possible to feel whether or not the pins are mated. If the coupling nut is difficult to turn, either the pins are not mated, the coupling nut is cross-threaded, or one of the connectors has been damaged by excess torque.

Never hold a male connector coupling nut stationary while screwing a female connector into it. This rotation can erode the plating and damage both the outer interface rim as well as the pin. If the pins become locked, serious damage can result to both the equipment and the cable assembly.

### **A-4 ENSURING PROPER CONNECTOR TORQUE.**

**A-4.1 OVERTORQUING.** Once connectors have been properly mated, apply only the proper amount of torque. Overtorquing damages both connectors involved. Also, a connector which has been damaged by overtorquing, in turn, damages every connector to which it is subsequently mated. It usually leads to poor system performance as well. Overtorque can cause:

- Bent pins.
- Recessed or protruding pins.
- Recessed or protruding dielectrics.
- Chipped plating.
- Damaged coupling threads.
- Coupling nut retaining ring damage.
- Mushroomed outer interface shells.
- Mushroomed pin shoulders.

**A-4.2 HEX-NUT TYPES.** To mate a connector of the hex-nut type, always use a torque wrench set to the correct torque value. Tighten the connector slowly until the wrench snaps. Tightening too quickly can cause the wrench to exceed its set limit. Do not snap the wrench more than once as this also causes overtorque.

**A-4.3 KNURLED NUTS.** Tighten connectors with knurled nuts by hand. If this does not provide sufficient tightness use a hex-nut connector and torque wrench instead. Never use pliers to tighten a connector. Table A-1 recommends torque specifications for the various types of connectors.

*Table A-1. Recommended Torque Values*

Connector	Recommended Torque
GPC-7 (7mm) w/hex nut	14 in/lbs ± 1 in/lbs
Type N w/hex nut	14 in/lbs ± 1 in/lbs
SMA, 2.92mm, 3.5mm 2.4mm, WPM, WPM-3 WPM-4	7.5 in/lbs ± 0.5 in/lbs
Type N & TNC (knurled)	Hand-tight
BNC (knurled)	Hand-tight

**A-5 PROPER CABLE HANDLING.**

Never exceed the minimum bend radius specified for a cable. Guard against tight bends at the end of connector strain relief tubing, or at the ends of marker tubing where they may be less noticeable. Although cable bend may seem slight, the actual radius of the bend at the point of angular departure may be far smaller than the acceptable radius.

Never pinch, crush or drop objects on cable assemblies. Also, do not drag a cable over sharp edges as this will pinch it and cause it to exceed the minimum bend radius.

Never use a cable assembly to pull a piece of equipment. Cables and connectors are not designed to support or move equipment.

**A-5.1 SECURING CABLES.** Use toothed, rubber-lined "P-clamps" to hold cables in place. If it is necessary to use tie-wraps, use the widest possible wrap and the lowest setting on the gun to ensure the minimum pressure on the cable.

**A-5.2 STORING CABLES.**When storing cables, minimize cable "set" by coiling them in large diameters (1 or 2 feet). Unroll the cable properly when it is ready to be used; do not pull the loops out hastily. Similarly, re-roll them when storing them away again.

**A-6 CLEANING CONNECTOR INTERFACES.**

Use the following guidelines in cleaning connector interfaces:

- a. Do not use chlorinated solvents including common tap water. These solvents are extremely penetrating and sometimes ruin otherwise good devices and assemblies.
- b. Moisten a cotton swab with isopropyl alcohol. Roll the swab on a paper towel to remove excess.
- c. Use the moistened cotton swab to wipe away debris. Do not try to dissolve the debris by overwetting the swab.
- d. Repeat the cleaning process using additional swabs as necessary. If metallic particles are embedded in the dielectric, use an eyeglass and a sharp pick in an attempt to dislodge them. Swab again.
- e. When satisfied that the interfaces are clean, blow them dry with dry compressed air, or preferably dry nitrogen (pressurized spray cans work well). Do not use breath.
- f. Clean the mating connectors. These may be the source of the debris.