

Programmable Attenuators



Models 4246 & 4248 Phase Compensated GaAs Switched Programmable Attenuator

10 MHz to 2.5 GHz
4 Watts

Low Insertion Loss, High IP3



Features

Ideal for use in Wireless/Cellular, RF simulation/Emulation, & Communication Test Applications.

- /// **Broadband Performance** - 10 MHz to 2.5 GHz
- /// **High IP3 and High Power Rating**
- Utilizes MESFET Switching
- /// **Flexible DC Voltage (+5 to +15 V)**
- /// **Low DC Power Consumption** - Ideal for portable battery powered equipment.
- /// **Custom Configurations including bus controlled attenuator subsystems**

Specifications

NOMINAL IMPEDANCE: 50 Ω
FREQUENCY RANGE: 10 MHz to 2.5 GHz

MAXIMUM SWR:	
Frequency Range	SWR
10 - 100 MHz	2.00
100 MHz - 200 MHz	1.60
200 MHz - 2.5 GHz	1.40

CELL CONFIGURATIONS:			
Model Number	NO. Cells	Attenuation Range/Steps (dB)	Cell Increments (dB)
4246-63	6	63/1	1, 2, 4, 8, 16, 32
4248-63.75	8	63.75/0.25	0.25, 0.50, 1, 2, 4, 8, 16, 32
4248-103	8	103/1	1, 2, 4, 8, 16, 24, 48*

*48 dB cell comprised of two 24 dB cells

INSERTION LOSS, Maximum (dB):		
Frequency Range	4246	4248
10 MHz - 1 GHz	8.0	10.5
1 - 2 GHz	9.0	12.0
2 - 2.5 GHz	10.0	13.0

INCREMENTAL ATTENUATION ACCURACY:										
CELL	0.25	0.50	1	2	4	8	16	24	32	48
dB	±0.15	±0.15	±0.2	±0.2	±0.2	±0.2	±0.3	±0.4	±0.6	±0.8

MONOTONICITY: 10 MHz to 2.5 GHz
3rd ORDER INTERMODULATION (IM3): -43 dBm typical, measured with two +27 dBm tones @ 869 MHz (f1) and 894 MHz (f2), the IM3 frequency being 844 MHz (2f1-f2).

$$IP3 \text{ (input)} = +58 \text{ dBm}$$

The input IP3 is derived from the following relationship:

$$IP3 = \frac{3(P_{in-\alpha}) - IM3}{2} + \alpha$$

where α = the insertion loss (dB) at the IM3 frequency;
Pin=single tone input power (dBm).

- POWER RATING:** 4 Watts maximum
- SWITCHING TIME:** 5 μsec. maximum
- OPERATING VOLTAGE:** + 5 V to +15V
- OPERATING CURRENT:** 25 mA typical
- INCREMENTAL RELATIVE PHASE:**

- ±5° between 0 and 0.25, 1, 2, 4, 8, 16 dB
- ±10° between 0 and 32, 48 dB

TEMPERATURE RANGE (Operating): 0°C to +70°C

TEMPERATURE COEFFICIENT: <0.002/dB/dB/°C

CONNECTORS: SMA female connectors - mate nondestructively with MIL-C-39012 connectors.

CONTROL CONNECTOR: AMP-Latch 10 pin ribbon cable connector mates with AMP P/N 746285-1 (supplied with each unit)

CONSTRUCTION:

- Housing: Aluminum
- Connectors: Stainless steel body and beryllium copper contacts.

WEIGHT: Model 4246: 227 g (8.0 oz)
Model 4248: 300 g (10.6 oz)

PHYSICAL DIMENSIONS:

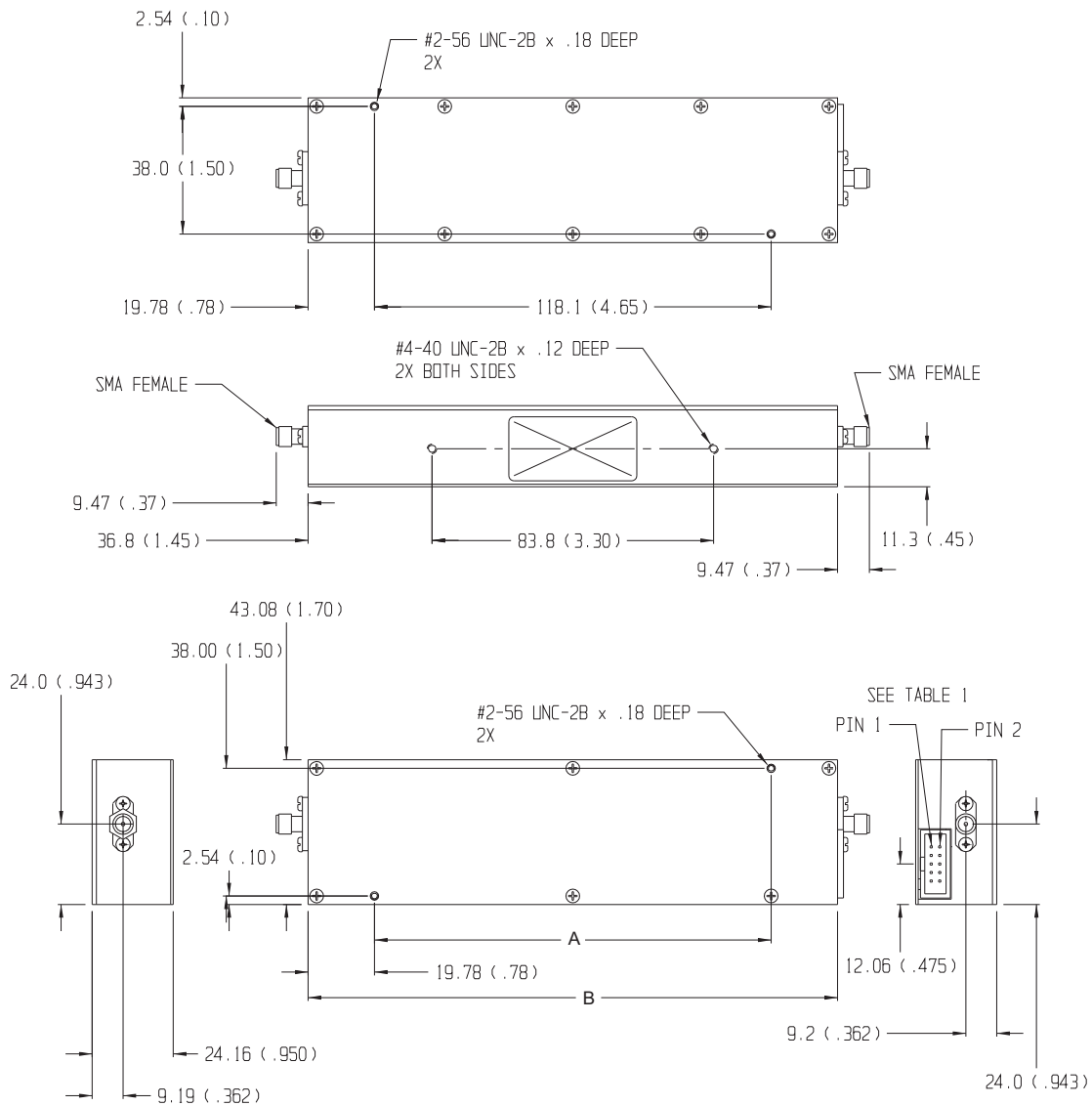

Control Connector J3 Pin Locations:

TTL Conn PIN No. (J3)	4238-63 dB (Cell)	4240-63.75 dB (Cell)	4240-103 dB (Cell)
1	1	0.25	1
2	2	0.50	2
3	4	1	4
4	16	2	8
5	32	4	16
6	8	8	24
7	NC	16	48
8	NC*	32	NC*
9	+5 Vdc	+5 Vdc	+5 Vdc
10	COM	COM	COM

NC = Not Connected
* For Factory use only.

Model No.	A	B
4246-X	82.50 (3.25)	122.50 (4.81)
4248-X	118.10 (4.65)	157.7 (6.21)

NOTE:

- All dimensions are given in mm (inches) and are maximum, unless otherwise specified.
- Unit available with RoHS compliant materials, specify when ordering.

CONTROL CONFIGURATION: Units are supplied with a built-in TTL interface. Each unit is supplied with a mating 10 pin connector (Amp 746285-1). Refer to Physical Dimensions for mating connector pin/wiring details. Two wires are specified for supply voltage and ground. The remaining wires will accept TTL control signals to activate or de-activate a particular attenuation cell. A TTL high will energize a cell to the high attenuation state, whereas a TTL low will maintain a cell in its zero attenuation state.