

# Model SPS-2000 Precision Positioner High Performance Positioning System

## Features

- Cost-effective solution for precise positioning of payloads weighing up to 500 lbs (227 Kg)
- Brushless, direct drive motors reduce maintenance and EMI
- Zero backlash, highly reliable direct drive eliminates gearboxes
- Coude' Optical Path (Optional)
- LOS Gyro Stabilization (Optional)
- Angular resolution of 21 bits
- C-based firmware: fast response, easy to use, flexible
- Controlled digitally via PC
- Suitable for operation in military land, sea, and airborne environments

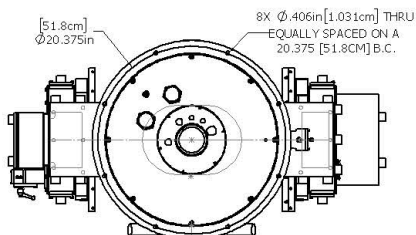
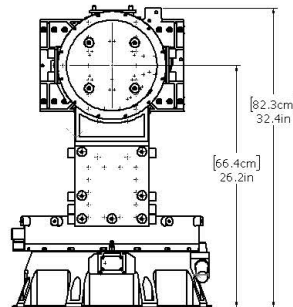
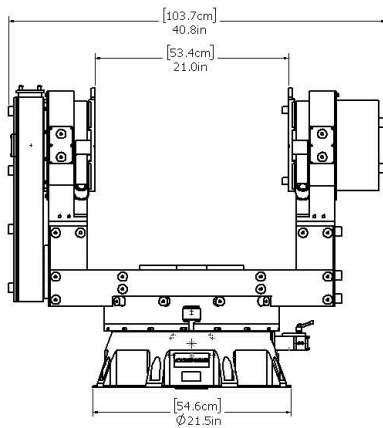

# Model SPS-2000 Precision Positioner High-Performance Positioning System

## Performance Specifications

<b>RESOLUTION:</b>	• 21 bits (3 $\mu$ radians)
<b>ACCURACY:</b>	• $\pm 50$ $\mu$ radians
<b>REPEATABILITY:</b>	• $\pm 12$ $\mu$ radians
<b>VELOCITY:</b>	• $0^\circ$ to $>100^\circ/\text{sec}$ (payload inertia dependent)
<b>ACCELERATION:</b>	• $>90^\circ/\text{sec}^2$ (payload inertia dependent)
<b>TRAVEL:</b>	• Azimuth - $\pm 180^\circ$ continuous • Elevation - $-15^\circ$ to $+195^\circ$
<b>RESONANT FREQUENCY:</b>	• Elevation 23 - 48 Hz
<b>3RD MODE:</b>	• Locked Azimuth $>30$ Hz
<b>MOTOR TORQUE (PEAK):</b>	• 200 ft - lb (271 N m) AZ • 85 ft - lb (115 N m) EL Standard

## Configuration

<b>PEDESTAL TYPE:</b>	• Direct drive, elevation over azimuth yoke
<b>DRIVE MOTORS:</b>	• Brushless DC
<b>WEIGHT, POSITIONER:</b>	• 265 lb (121 Kg)
<b>PAYLOAD:</b>	• Up to 500 lb (227 Kg)

## Environmental

<b>TEMPERATURE:</b>	• $-40^\circ$ to $+55^\circ\text{C}$
<b>RAIN:</b>	• Weather tight seals
<b>RELATIVE HUMIDITY:</b>	• 98%
<b>SHOCK &amp; VIBRATION:</b>	• MIL Standard levels

## Mechanical

<b>MOUNTING:</b>	12 x 0.406 inch diameter holes on a 20.375 inch diameter bolt circle
<b>LOS:</b>	26.20 inches above the positioner mounting surface

## Power / Voltage

The Positioner derives its power from the servo control unit. The servo control unit operates from:

- 115 VAC single phase, 50/60 HZ power
- 3,450 Watts (peak) depending on dynamic requirements

## Options

SPS-2000 has many options from past programs such as, Sliprings, FORJ, Transportable Base, and Customer Cabling through the positioner. Let us know any desired features or optional interfaces, as they already exist

## Corrosion Prevention and Safety

The pedestal is pretreated with chemical conversion coating and a weather resistant urethane top coat. It uses all stainless steel hardware and is supplied with stow locks for safe transportation. A pedestal safe switch is included to allow maintenance personnel to immobilize the pedestal during maintenance. Mechanical stops and a payload specific electrical interface are also standard items