

# Phase Locked Dielectric Resonator Oscillators Series PDRO

---



Supplying high performing, innovative and sophisticated RF, microwave, millimeter wave components and integrated assemblies worldwide.

CAES' series of phase locked dielectric resonator oscillators have been designed for use in commercial and military systems where demanding performance, high reliability and cost are critical.

This family of product takes advantage of the small size, low phase noise and high efficiency offered by fundamental GaAs MESFET and BJT DROs when they are phase locked to an external crystal reference in the 1 MHz to 1 GHz frequency range.

The single loop model when phase locked to an external 100 MHz crystal reference provides exceptionally low phase noise, typically -120 dBc/Hz at 10 kHz offset from the carrier at an output frequency of 10 GHz. In addition, two reference options are available. The first option offers an integrated, high stability internal crystal oscillator in the 100 MHz range in a slim line package.

The second option offers a dual loop design enabling the output frequency to be phase locked to an integer or fractional multiple of the reference frequency used.

Features such as the low phase noise, high power, small size and low cost make Ultra's PDRO product line the best value on the market today.

Contact the factory to discuss your special requirements.

# Phase Locked Dielectric Resonator Oscillators Series PDRO

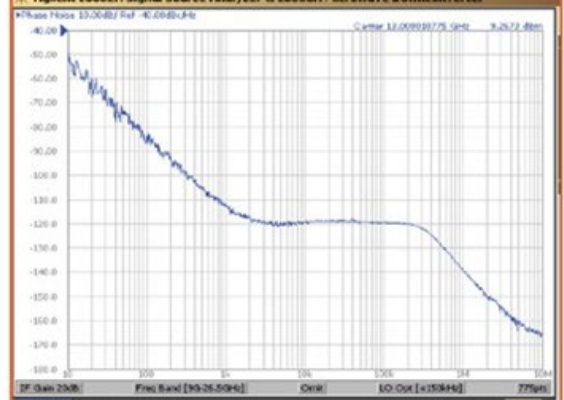

Standard Outline Drawing for External Reference Models up to 18 GHz  
 Note: for frequencies <4 GHz will be 0.82 inches/20.82mm.

Standard Outline Drawing for Internal Reference & Dual Loop Models up to 18 GHz  
 Note: for frequencies <4 GHz will be 0.82 inches/20.82mm.  
 Note 2: REF MON connector becomes REF IN on dual loop models.

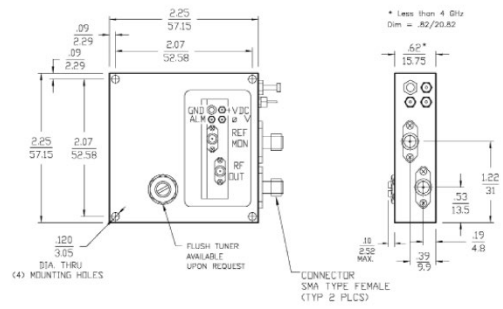
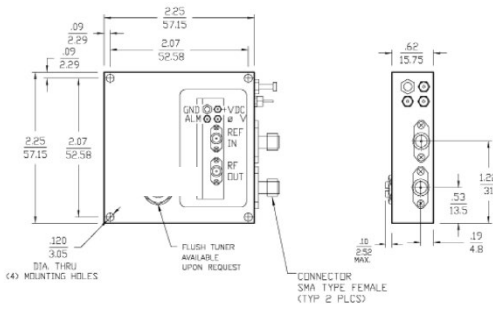

Standard Outline Drawing for Frequencies From 18 GHz to 45 GHz  
 Note: Output connector will be 2.92 mm female for frequencies Above 26 GHz.  
 Note 2: REF IN connector becomes REF MON on internal Reference Models

Miniature Outline Drawing for Frequencies from 8 GHz to 18 GHz

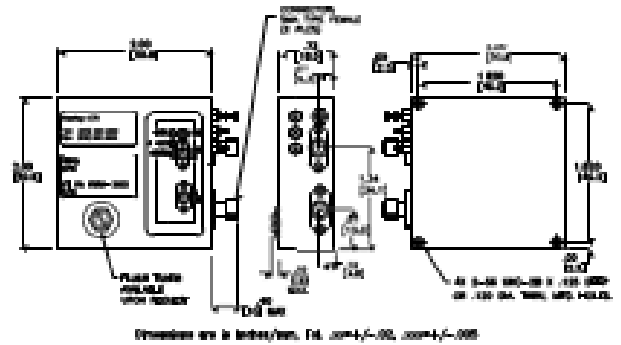
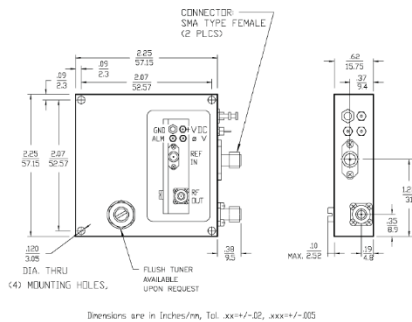

PRODUCT BRIEF

RELEASE DATE 12/31/2021

# Phase Locked Dielectric Resonator Oscillators Series PDRO

## Typical Phase Noise

### External Reference Models

| Offset | SSB Phase Noise dBc/Hz at |        |        |
|--------|---------------------------|--------|--------|
|        | KHz                       | 10 GHz | 14 GHz |
| 0.1    | -85                       | -82    | -76    |
| 1.0    | -110                      | -107   | -101   |
| 10     | -120                      | -117   | -107   |
| 100    | -120                      | -117   | -110   |
| 1,000  | -135                      | -135   | -125   |
| 10,000 | -160                      | -160   | -150   |

## Typical Phase Noise

### Internal Reference Models

| Offset | SSB Phase Noise dBc/Hz at |        |        |
|--------|---------------------------|--------|--------|
|        | KHz                       | 10 GHz | 14 GHz |
| 0.1    | -75                       | -72    | -66    |
| 1.0    | -105                      | -92    | -96    |
| 10     | -120                      | -116   | -107   |
| 100    | -120                      | -116   | -110   |
| 1,000  | -135                      | -135   | -125   |

## Typical Phase Noise

### Dual Loop Models

| Offset | SSB Phase Noise dBc/Hz at |        |        |
|--------|---------------------------|--------|--------|
|        | KHz                       | 10 GHz | 14 GHz |
| 0.1    | -70                       | -67    | -61    |
| 1.0    | -100                      | -97    | -91    |
| 10     | -120                      | -116   | -107   |
| 100    | -120                      | -116   | -110   |
| 1,000  | -135                      | -135   | -125   |
| 10,000 | -160                      | -160   | -150   |

# Phase Locked Dielectric Resonator Oscillators Series PDRO

---

## FEATURES:

- Frequencies from 3 to 45 GHz
- Wide operating temperature
- Ultra-low phase noise
- Low power consumption
- Phase lockable to references from 1 MHz to 1 GHz
- Low Spurious
- Fractional reference multiplication in a single loop
- Internal reference and dual loop models in a low-profile housing

## OPTIONS:

- +8 VDC supply on certain models
- Field replaceable connectors
- Flush profile tuner
- Hermetic seal
- Extended temperature ranges
- Dual loop models
- Dual output models

## TYPICAL PERFORMANCE SPECIFICATIONS:

- Fixed frequencies from 3 GHz to 45 GHz
- Output power +15 dBm standard, up to 1 W optional
- Power variation  $\pm 2$  dBm
- Load VSWR 2:1
- Output impedance 50 ohms
- Spurious -80 dBc typical, -70 dBc max
- Harmonics -20 dBc
- Lock alarm TTL high when locked
- Input reference frequency 1 MHz to 1 GHz for single loop models, 1 MHz to 100 MHz for dual loop models
- Input reference power level  $0 \pm 3$  dBm
- Internal reference models frequency stability  $\pm 2.5$  ppm standard,  $\pm 1$  ppm optional
- External reference models frequency stability same as reference

## CONNECTORS:

- RF output SMA-F to 26 GHz, 2.92 mm above 26 GHz
- Reference input SMA-F
- Alarm Feed-thru
- Supply voltage Feed-thru
- Ground solder lug

## POWER, DIMENSIONS AND ENVIRONMENTAL

- Supply voltage +12V, +15 V and +8 VDC on select models
- Current 300 mA to 450 mA depending on model

# Phase Locked Dielectric Resonator Oscillators Series PDRO

---

- Operating temperature -40° to +70° centigrade
  - Storage temperature -54° to +85° centigrade
- 

\* Product in development, targeted specification